



Industrial Ni-Cd Batteries

A global capability

Delivering quality

ALCAD

ALCAD Delivering

Alcad nickel-cadmium – the battery of choice for *reliability*.

We will make sizing, ordering and installation *easy*.

Wherever you are located, the after-sales service, the reliable product, and the highly motivated Alcad team will give *customer satisfaction*.

Alcad, its people and its products, will support you from the start, *delivering quality*.

Alcad operate on a global scale, designing, manufacturing, installing, servicing and recycling nickel-cadmium batteries. These are used in all types of industry, often in extreme climatic conditions.

Worldwide, demand is growing for reliable standby power. Alcad can offer an extensive range of cell types to meet this demand.

Alcad's real strength lies in its people. Their experience and commitment will produce high quality, reliable batteries for your back-up system.

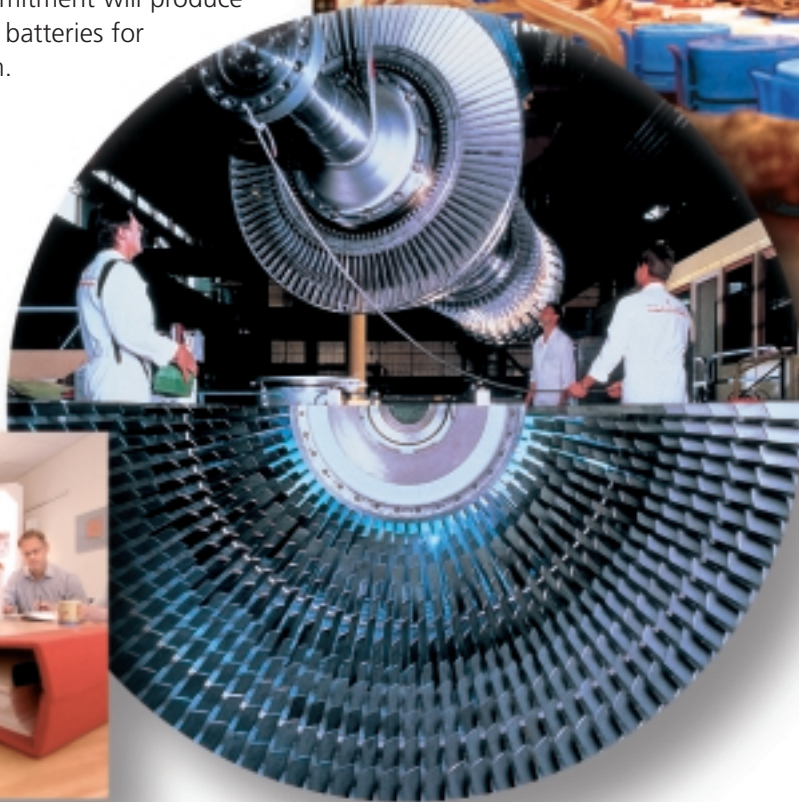

quality

Alcad ranges enable tailored solutions, optimised for individual applications and operating conditions.



	Single Cell			Battery type	XHP	Solar
	L	M	H	Vantage		
Plate technology	Pocket	Pocket	Pocket	Pocket	Sintered/pbe	Pocket
Capacity range Ah	10–1540	9–1390	9–920	8–476	11–320	45–1110
Use of battery	Power back-up Storage	Power back-up	Power back-up Starting	Power back-up	Power back-up Starting	Energy storage
Applications	Engine starting, switchgear, UPS, process control, data and information, emergency lighting, security and fire alarms, switching and transmissions, signalling					Renewable, photovoltaic, wind and hybrid systems

Alcad batteries are deployed in all kinds of industry, worldwide.

- **Utilities** electricity, gas, water production and distribution
- **Oil and gas** offshore and onshore, petrochemical refineries
- **Industry** chemical, mining, steel works
- **Buildings** public, private
- **Medical** hospitals, X-ray equipment
- **Telecom** radio, satellite, cable, repeater stations, cellular base stations
- **Railways** substations and signalling
- **Airports** critical back-up power for emergency generators, air traffic control systems
- **Renewable energies** photovoltaic applications and stand-alone hybrid systems



Why do I need a battery?

It is a false economy not to address the threats of a power loss. A battery is the final defence in the event of a power failure and will allow you to –

- maintain critical loads
- start alternative generators
- have peace of mind

Why is nickel-cadmium my best choice?

Your battery is your insurance policy, and nickel-cadmium is the most reliable owing to the alkaline chemistry.

A nickel-cadmium battery gives –

- unsurpassed operation in extreme temperatures:
-50°C to +60°C (-58°F to +140°F)
- no risk of sudden death – or thermal runaway
- extended storage time
- excellent resistance to over-charge and over-discharge
- low life cycle cost

It's reliable - but how much maintenance will it require?

Alcad nickel-cadmium technology provides a lifetime of reliability in return for regular inspection –

- no special charging equipment needed
- easy visual checking of electrolyte levels
- minimal topping up requirement – for some ranges up to 20 years' interval in standby applications

Cost of failure? What failure, what cost?

Imagine –

- your hospital generator fails to start;
penalty – potential loss of life?
- your data centre without power;
penalty – re-installation and lost business.
- your emergency lighting fails during a fire;
penalty – potential loss of life?
- your process control without power back-up;
penalty – no control over shut-down.

It is essential that a back-up system really works when you need it. Do not put your installation at risk. Reliability is more important than initial savings on a low cost battery.



OUR CLIENTS

ADCO, THE UAE
ADMA-OPCO, THE UAE
ADWEA, ABU DHABI WATER AND
ELECTRIC AUTHORITY
ALEXANDRIA PETROLEUM, EGYPT
APO CEMENT CORPORATION

ARAMCO, SAUDI ARABIA
BAN YU PAPER MILL CO. LTD.
BANIAS REFINERY
BRITISH GAS TRANSCO
BROWN & ROOT
BUNDUG

CAAS - SINGAPORE
CATERPILLAR
CEA, EGYPT
CEGELEC
CEMENTHAI CHEMICALS CO. LTD.
CHANNEL TUNNEL RAIL LINK

CHINA LIGHT AND POWER CO. LIMITED
CHINA PETROLEUM CORPORATION
CHINA STEEL CORPORATION
CHLORIDE
CKS AIRPORT
CLP, CHINA LIGHT AND POWER, HONG KONG

CUMMINGS
DALE POWER SYSTEMS PLC
DEWA, DUBAI ELECTRICITY AND
WATER AUTHORITY
DOCKLANDS LIGHT RAIL
DUGAS, DUBAI

EAC, CYPRUS
EGYPT ELECT. AUTHORITY
EGYPT RAILWAYS
EMERGI-LITE
ESCOM, SOUTH AFRICA
EUAS/TEAS, TURKEY



But can I afford nickel-cadmium?

Can you afford to take the risk **not** to install the most reliable battery? Consider –

- the cost for the battery is very low compared to the values it protects
- whole life cost is more important than initial cost
- long life gives lower total cost and better reliability by avoiding repeated battery replacements.

How will Alcad support my investment in Nickel-Cadmium?

Alcad's good reputation has been earned over decades of close, productive partnership with customers worldwide.

Alcad's promise is to *deliver quality*, with –

- prompt, decisive service from experienced staff
- engineering expertise
- analysis and advice on your battery application needs
- ISO 9001 accredited facilities
- worldwide warranty available
- full recycling service

What do I do next?

The Alcad international sales and service network is in place to help you –

- discuss and formulate your battery requirement
- complete purchasing schedules
- plan the logistics of your delivery and installation

Simply contact your Alcad Sales Office as listed on the reverse of this brochure.

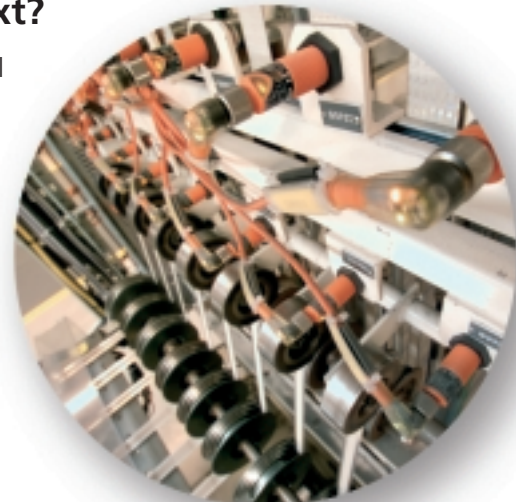

quality



Alcad's production sites in Europe together bring over a century of experience in nickel-cadmium battery production to the modern, international battery market.

Well trained and dedicated people are employed at the ISO 9001 / ISO 14001 certified sites. Regular training programmes, coupled with personal commitment, ensure that all staff have a good knowledge of the product, maintaining Alcad's high manufacturing standard.



MASS TRANSIT RAILWAY CORPORATION
ME A THAILAND
MG HONG KONG
MG SINGAPORE
MINISTRY OF ENVIRONMENT

MITSUBISHI
MONTANA POWER COMPANY
MOTOROLA
NATIONAL FERTILIZER COMPLEX
NATIONAL RAILWAY SUPPLIES LTD
NETWORK RAIL

NIGC, IRAN
NNPC, NIGERIA
NORTHERN IRELAND RAIL
NORTHERN LIGHTHOUSE BOARD
OMAN REFINERY, OMAN
ORESUNDSBROKONSORTIET

P & O SHIPPING
PDO, OMAN
PDVSA, VENEZUELA
PEC, YEMEN
PEDEEE, SYRIA
PEEGT, SYRIA

PEMEX, MEXICO
PETRONAS, MALAYSIA
PHILIPPINES NATIONAL POWER CORPORATION
PLN INDONESIA
PPC, GREECE

Q. G. P. C.
QNPC, QATAR
RASCO, LIBYA
SALCON POWER CORPORATION
SAUDI ARAMCO
SAUDI NATIONAL GUARD



Production at Alcad factories is efficient, highly automated, and fully committed to environmental protection.

Alcad support customers in their Ni-Cd investment right from the start. At the end of battery life, Alcad recycle old batteries as part of their responsibility. Around 30% of cadmium used is material recycled in Alcad's own facilities.

SAUDI OIL CO
SCECO
SCHNEIDER
SCOTTISH POWER PLC
SEC/SCECO, SAUDI ARABIA
SHANGHAI BAOSHAN STEEL MILL

SHELL BRUNEI
SHELL MALAYSIA
SHELL SINGAPORE
SHELL UK
SIEL
SINGAPORE POWERGRID

SINGAPORE SCIENCE PARK
SIRTE OIL CO., LIBYA
SOUTH WALES ELECTRICITY BOARD
STERING FLUID SYSTEM
SLINGTON
SYRIAN ELECT. AUTH.

SYRIAN PETROL CO
SYRIAN RAILWAYS
TAIWAN POWER COMPANY
TAIWAN RAILWAY ADMINISTRATION
TAIWAN WATER SUPPLY CORPORATION
THE NATURAL HISTORY MUSEUM, LONDON

THE SCIENCE MUSEUM, LONDON
TUNTEX GROUP
TYNE & WEAR METRO
UNIPART RAIL LOGISTICS/EXEL
VICTORIA & ALBERT MUSEUM, LONDON
WEI CHIH STEEL INDUSTRIAL CO.LTD.

WED
WESTINGHOUSE BRAKE AND
SIGNAL CO.
YI JINN INDUSTRIAL CO. LTD.
ZADCO, THE UAE

Single Cell Range including LCE P – LBE P

Alcad have nearly 100 years' experience in the development and manufacture of pocket plate cells and batteries.

Today, they offer the widest range of high quality nickel-cadmium batteries available throughout the world and this publication details the Single Cell ranges of pocket plate products.

Alcad nickel-cadmium batteries are the battery of choice for many applications. Their outstanding features are :

- operation over a temperature range between -20°C to $+50^{\circ}\text{C}$ (-4°F to $+122^{\circ}\text{F}$), with extremes of -50°C to $+70^{\circ}\text{C}$ (-58°F to $+158^{\circ}\text{F}$) for short periods
- life in excess of 25 years in many applications
- good performance at low temperatures
- resistance to high temperature ageing
- resistance to electrical abuse
- resistance to shock and vibration
- simple maintenance
- low installation cost
- low life-cycle cost

The major design features of the Alcad Single Cell ranges are :

- fully welded internal construction of steel components
- strong welded polypropylene containers as standard
- flame retardant welded containers, as option
- flip-top flame arresting vents as standard

Alcad supports these Single Cell ranges with :

- quality approved manufacture to ISO 9001
- Single Cell batteries have been developed in line with the safety requirements of EN-50272-2 and components used (such as insulated cable connectors and end lug covers) are defined to ensure high protection against electric shocks (IP2 level).
- full recycling service to protect the environment

The Alcad Single Cell ranges meet, and exceed, the requirements of the IEC 60623 standard.

The Single Cell portfolio comprises three ranges of high, medium and low rate discharge types.

L type

The L type range has the thickest plates and is designed for applications where the battery is required to provide a reliable source of energy over relatively long discharge periods.

Normally, the current is relatively low in comparison with the total stored energy and the discharges are generally infrequent. Typical uses are power back-up and bulk energy storage.

M type

The M type range is designed for applications where the batteries are usually required to sustain electrical loads for between 30 minutes to 3 hours or for « mixed » loads which involve a mixture of high and low discharge rates.

The applications can have frequent or infrequent discharges. The range is typically used in power back-up applications.

H type

The H type range uses very thin plates and is designed for applications where there is a demand for a relatively high current over short periods, usually less than 30 minutes in duration.

The applications can have frequent or infrequent discharges. The range is typically used in starting and power back-up applications.





Contents

Construction features 4

LE range

- Cell dimensions and internal resistance 5
- Cell performance data 6

M range

- Cell dimensions and internal resistance 10
- Cell performance data 11

H range

- Cell dimensions and internal resistance 15
- Cell performance data 16

Battery layout 21

Battery racks 23

Disposal and recycling 26

Float-corrected data

Many nickel-cadmium batteries are used in stationary standby power applications where discharges occur infrequently and the battery is continuously charged by a float or constant potential charge. Under these circumstances there is a modification in the level of the discharge curve and allowances must be made for this when sizing the battery.

In order to simplify this process, the data Alcad supplies in this publication already takes into account this phenomenon. The data published by Alcad is the performance after prolonged floating and it can be used directly in battery sizing calculations.

This phenomenon occurs with all nickel-cadmium batteries, but some other manufacturers of nickel-cadmium batteries may not take this effect into account in published data.

When calculating for deep discharges (0.65 V and 0.85 V) it is not necessary to take this effect into account.

Single Cell Construction features

Connector cover
In line with EN 50272-2 (safety) with IP2 level.

Plate group bus
Connects the plate tabs with the terminal post. Plate tabs and terminal posts are projection welded to the plate group bus.

Plate
Horizontal pockets of double-perforated steel strips.

Flame-arresting vent

Terminal seal
This is mechanically clipped and provides an excellent seal. This minimises carbonation deposits.

Plate tab
Spot welded to the plate side frames, to the upper edge of the pocket plate and to the plate group bus.

Separating grids
These separate the plates and insulate the plate frames from each other. The grids allow free circulation of electrolyte between the plates.

Plate frame
Seals the plate pockets and serves as a current collector.



The Alcad Single Cell ranges fully comply and exceed the IEC 60623 standard requirements.

Cell dimensions and internal resistance

LE Range

LE cells are normally supplied as single cells, taped together into blocks or assembled in steel crates.

Cell type	Capacity at the 5h rate (Ah)	Volume of liquid electrolyte above plates (cc)	Approx. weight per cell		Overall height		Width per cell		Length per cell		Internal resistance* (mOhm)	Electrolyte height between Min - Max (mm)
			(kg)	(lb)	(mm)	(ins)	(mm)	(ins)	(mm)	(ins)		
LCE10P	10	146	1.6	3.6	275	10.83	121	4.76	42	1.65	14.4	35
LCE15P	15	146	1.7	3.7	275	10.83	121	4.76	42	1.65	9.60	35
LCE22P	22	143	1.9	4.1	275	10.83	121	4.76	42	1.65	6.55	35
LCE30P	30	143	2.0	4.3	275	10.83	121	4.76	42	1.65	4.80	35
LCE40P	40	235	3.1	6.8	275	10.83	121	4.76	66	2.60	3.60	35
LCE47P	47	238	3.0	6.6	275	10.83	121	4.76	66	2.60	3.06	35
LCE62P	62	235	3.3	7.3	275	10.83	121	4.76	66	2.60	2.32	35
LCE75P	75	559	6.0	13.1	358	14.09	192	7.56	68	2.68	2.33	50
LCE90P	90	552	6.6	14.6	358	14.09	192	7.56	68	2.68	1.94	50
LCE110P	110	552	6.6	14.6	358	14.09	192	7.56	68	2.68	1.59	50
LCE145P	145	546	7.2	15.9	358	14.09	192	7.56	68	2.68	1.21	50
LCE185P	185	771	9.6	21.1	358	14.09	192	7.56	93	3.66	0.95	50
LCE220P	220	765	10.2	22.5	358	14.09	192	7.56	93	3.66	0.80	50
LCE235P	235	771	12.1	26.7	414	16.30	192	7.56	93	3.66	0.77	50
LCE280P	280	765	12.8	28.3	414	16.30	192	7.56	93	3.66	0.65	50
LCE330P	330	1020	16.6	36.5	414	16.30	192	7.56	122	4.80	0.55	50
LCE375P	375	1015	17.2	37.8	414	16.30	192	7.56	122	4.80	0.48	50
LBE415P	415	1090	18.3	40.3	405	15.94	195	7.68	146	5.75	0.44	50
LBE460P	460	1180	19.8	43.7	405	15.94	195	7.68	159	6.26	0.39	50
LBE510P	510	1290	21.4	47.2	405	15.94	195	7.68	171	6.73	0.35	50
LBE550P	550	1400	23.0	50.7	405	15.94	195	7.68	183	7.20	0.33	50
LBE600P	600	1590	26.7	58.9	405	15.94	195	7.68	206	8.11	0.30	50
LBE650P	650	1680	28.2	62.2	405	15.94	195	7.68	219	8.62	0.28	50
LBE700P	700	1770	29.7	65.5	405	15.94	195	7.68	232	9.13	0.26	50
LBE750P	750	1880	31.3	69.0	405	15.94	195	7.68	244	9.61	0.24	50
LBE830P	830	2100	34.5	76.1	405	15.94	195	7.68	268	10.55	0.22	50
LBE925P	925	2360	39.6	87.3	405	15.94	195	7.68	304	11.97	0.20	50
LBE1020P	1020	2580	42.8	94.4	405	15.94	195	7.68	328	12.91	0.18	50
LBE1100P	1100	2800	46.0	101.4	405	15.94	195	7.68	352	13.86	0.16	50
LBE1200P	1200	3060	51.1	112.7	405	15.94	195	7.68	389	15.31	0.15	50
LBE1300P	1300	3300	54.3	119.7	405	15.94	195	7.68	413	16.26	0.14	50
LBE1400P	1400	3500	57.5	126.8	405	15.94	195	7.68	437	17.20	0.13	50
LBE1500P	1500	3900	64.2	141.5	405	15.94	195	7.68	486	19.13	0.12	50
LBE1600P	1600	4090	67.4	148.6	405	15.94	195	7.68	510	20.08	0.11	50
LBE1660P	1660	4200	69.0	152.1	405	15.94	195	7.68	522	20.55	0.11	50

*Rigid connector included

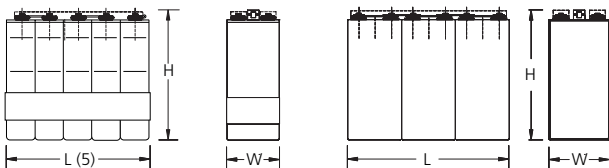

LCE10P - LCE375P
Taped block length =
cell length x no of cells + 2mm/0.1 in.

LBE415P - LBE1660P

Cell connection bolt per pole:	LBE415P to LBE550P:	2 x M10	
LCE10P to LCE62P:	M6	LBE600P to LBE830P:	3 x M10
LCE75P to LCE90P:	M8	LBE925P to LBE1100P:	4 x M10
LCE110P to LCE280P:	M10	LBE1200P to LBE1400P:	5 x M10
LCE330P to LCE375P:	2 x M10	LBE1500P to LBE1660P:	6 x M10

LE Range Cell performance

Available amperes at +20°C ± 5°C (+68°F ± 9°F)
Performance after prolonged float charge of fully charged cells

Final voltage: 1.00 V/cell

Cell type	C ₅ Ah	HOURS					MINUTES									SECONDS		
		10 h	8 h	5 h	3 h	2 h	90 min	60 min	45 min	30 min	20 min	15 min	10 min	5 min	1 min	30 s	5 s	1 s
LCE10P	10	1.03	1.28	2.00	3.20	4.23	5.10	6.46	7.50	8.96	10.1	10.9	12.0	14.4	17.9	19.8	25.5	28.7
LCE15P	15	1.54	1.91	3.00	4.80	6.35	7.65	9.69	11.3	13.4	15.1	16.3	18.0	21.6	26.8	29.7	38.3	43.1
LCE22P	22	2.26	2.81	4.40	7.04	9.31	11.23	14.2	16.5	19.7	22.2	23.9	26.4	31.7	39.3	43.6	56.1	63.2
LCE30P	30	3.08	3.83	6.00	9.60	12.7	15.3	19.4	22.5	26.9	30.3	32.6	36.0	43.2	53.6	59.4	76.6	86.2
LCE40P	40	4.10	5.10	8.00	12.8	16.9	20.4	25.8	30.0	35.9	40.3	43.5	48.0	57.6	71.4	79.3	102	115
LCE47P	47	4.82	5.99	9.40	15.0	19.9	24.0	30.4	35.3	42.1	47.4	51.1	56.4	67.7	83.9	93.1	120	135
LCE62P	62	6.36	7.91	12.4	19.8	26.2	31.6	40.1	46.5	55.6	62.5	67.5	74.4	89.3	111	123	158	178
LCE75P	75	7.58	9.47	15.0	24.0	32.1	37.8	46.5	52.9	61.6	69.3	73.2	79.2	90.0	113	121	154	171
LCE90P	90	9.09	11.4	18.0	28.8	38.5	45.4	55.8	63.5	74.0	83.1	87.8	95.0	108	135	145	185	205
LCE110P	110	11.1	13.9	22.0	35.2	47.1	55.5	68.3	77.6	90.4	102	107	116	132	166	177	226	251
LCE145P	145	14.6	18.3	29.0	46.4	62.0	73.1	90.0	102	119	134	142	153	174	218	234	298	331
LCE185P	185	18.7	23.4	37.0	59.2	79.1	93.3	115	131	152	171	181	195	222	278	299	380	422
LCE220P	220	22.2	27.8	44.0	70.4	94.1	111.0	137	155	181	203	215	232	264	331	355	452	502
LCE235P	235	24.2	30.0	47.0	75.2	98.3	115.7	142	163	189	211	226	248	271	329	353	423	455
LCE280P	280	28.8	35.7	56.0	89.6	117	138	169	194	225	252	269	296	323	392	420	504	542
LCE330P	330	34.0	42.1	66.0	106	138	163	199	229	266	297	317	348	380	461	495	594	639
LCE375P	375	38.6	47.8	75.0	120	157	185	226	260	302	337	360	396	432	524	563	675	726
LBE415P	415	42.7	52.9	83.0	133	174	204	250	288	334	373	398	438	478	580	623	747	804
LBE460P	460	47.4	58.7	92.0	147	193	227	278	319	370	414	442	486	530	643	690	829	891
LBE510P	510	52.5	65.0	102	163	213	251	308	354	411	459	490	539	588	713	766	919	988
LBE550P	550	56.7	70.1	110	176	230	271	332	382	443	495	528	581	634	769	826	991	1065
LBE600P	600	61.8	76.5	120	192	251	295	362	417	483	539	576	634	691	839	901	1081	1162
LBE650P	650	67.0	82.9	130	208	272	320	392	451	523	584	624	686	749	909	976	1171	1259
LBE700P	700	72.1	89.3	140	224	293	345	422	486	564	629	672	739	806	979	1051	1261	1355
LBE750P	750	77.3	95.6	150	240	314	369	453	521	604	674	720	792	864	1049	1126	1351	1452
LBE830P	830	85.5	106	166	266	347	409	501	576	668	746	797	876	956	1161	1246	1495	1607
LBE925P	925	95.3	118	185	296	387	456	558	642	745	832	888	977	1066	1294	1388	1666	1791
LBE1020P	1020	105	130	204	326	427	502	616	708	821	917	979	1077	1175	1426	1531	1837	1975
LBE1100P	1100	113	140	220	352	460	542	664	764	886	989	1056	1162	1267	1538	1651	1981	2130
LBE1200P	1200	124	153	240	384	502	591	724	833	966	1079	1152	1267	1382	1678	1801	2161	2324
LBE1300P	1300	134	166	260	416	544	640	785	903	1047	1169	1248	1373	1498	1818	1951	2342	2517
LBE1400P	1400	144	179	280	448	586	689	845	972	1127	1259	1344	1478	1613	1958	2101	2522	2711
LBE1500P	1500	155	191	300	480	628	739	905	1042	1208	1349	1440	1584	1728	2098	2252	2702	2904
LBE1600P	1600	165	204	320	512	670	788	966	1111	1288	1439	1536	1690	1843	2237	2402	2882	3098
LBE1660P	1660	171	212	332	531	695	817	1002	1153	1336	1493	1594	1753	1912	2321	2492	2990	3214

Cell performance **LE Range**

Available amperes at +20°C ± 5°C (+68°F ± 9°F)
Performance after prolonged float charge of fully charged cells

Final voltage: 1.05 V/cell

Cell type	C ₅ Ah	HOURS					MINUTES									SECONDS		
		10 h	8 h	5 h	3 h	2 h	90 min	60 min	45 min	30 min	20 min	15 min	10 min	5 min	1 min	30 s	5 s	1 s
LCE10P	10	1.02	1.26	1.96	3.10	3.94	4.53	5.62	6.29	7.36	8.53	9.20	10.2	10.7	14.4	16.2	21.1	23.8
LCE15P	15	1.53	1.89	2.94	4.65	5.90	6.79	8.43	9.44	11.0	12.8	13.8	15.2	16.0	21.6	24.3	31.6	35.6
LCE22P	22	2.24	2.78	4.31	6.82	8.66	9.96	12.4	13.8	16.2	18.8	20.2	22.4	23.4	31.7	35.6	46.4	52.3
LCE30P	30	3.06	3.79	5.88	9.30	11.8	13.6	16.9	18.9	22.1	25.6	27.6	30.5	32.0	43.2	48.5	63.3	71.3
LCE40P	40	4.08	5.05	7.84	12.4	15.7	18.1	22.5	25.2	29.4	34.1	36.8	40.7	42.6	57.6	64.7	84.4	95.0
LCE47P	47	4.79	5.93	9.21	14.6	18.5	21.3	26.4	29.6	34.6	40.1	43.3	47.8	50.1	67.7	76.0	99.1	112
LCE62P	62	6.32	7.83	12.2	19.2	24.4	28.1	34.8	39.0	45.6	52.9	57.1	63.0	66.1	89.4	100	131	147
LCE75P	75	7.50	9.38	14.7	23.5	29.3	33.5	39.4	44.0	50.4	56.9	60.8	65.8	73.3	90.7	100	127	140
LCE90P	90	9.00	11.3	17.6	28.2	35.2	40.2	47.2	52.8	60.5	68.3	73.0	79.0	87.9	109	120	152	168
LCE110P	110	11.0	13.8	21.6	34.5	43.0	49.2	57.7	64.5	73.9	83.4	89.2	96.6	107	133	147	186	205
LCE145P	145	14.5	18.1	28.4	45.4	56.7	64.8	76.1	85.1	97.4	110	118	127	142	175	194	245	270
LCE185P	185	18.5	23.1	36.3	58.0	72.4	82.7	97.1	109	124	140	150	162	181	224	247	312	345
LCE220P	220	22.0	27.5	43.1	68.9	86.1	98.4	115	129	148	167	178	193	215	266	294	371	410
LCE235P	235	24.0	29.8	46.5	72.9	90.9	102.4	121	135	154	170	176	195	230	264	289	347	377
LCE280P	280	28.6	35.5	55.4	86.8	108	122	145	161	184	202	210	233	274	315	344	413	449
LCE330P	330	33.7	41.9	65.3	102	128	144	170	190	216	239	247	274	322	371	406	487	529
LCE375P	375	38.3	47.6	74.3	116	145	163	194	216	246	271	281	312	366	422	461	554	601
LBE415P	415	42.3	52.7	82.2	129	161	181	214	239	272	300	311	345	405	467	511	613	665
LBE460P	460	46.9	58.4	91.1	143	178	200	238	265	302	333	344	383	449	517	566	679	737
LBE510P	510	52.0	64.7	101	158	197	222	263	294	335	369	382	424	498	574	627	753	817
LBE550P	550	56.1	69.8	109	171	213	240	284	317	361	398	412	457	537	619	677	812	882
LBE600P	600	61.2	76.1	119	186	232	261	310	346	394	434	449	499	586	675	738	886	962
LBE650P	650	66.3	82.5	129	202	251	283	336	374	426	470	487	541	635	731	800	960	1042
LBE700P	700	71.4	88.8	139	217	271	305	362	403	459	506	524	582	684	787	861	1033	1122
LBE750P	750	76.5	95.2	149	233	290	327	387	432	492	542	562	624	733	844	923	1107	1202
LBE830P	830	84.7	105	164	257	321	362	429	478	544	600	622	690	811	934	1021	1225	1330
LBE925P	925	94.4	117	183	287	358	403	478	533	607	669	693	769	904	1040	1138	1366	1483
LBE1020P	1020	104	129	202	316	394	444	527	588	669	737	764	848	996	1147	1255	1506	1635
LBE1100P	1100	112	140	218	341	425	479	568	634	722	795	824	915	1074	1237	1353	1624	1763
LBE1200P	1200	122	152	238	372	464	523	620	691	787	867	899	998	1172	1350	1476	1772	1923
LBE1300P	1300	133	165	257	403	503	566	672	749	853	940	973	1081	1270	1462	1599	1919	2084
LBE1400P	1400	143	178	277	434	541	610	723	806	918	1012	1048	1164	1368	1575	1722	2067	2244
LBE1500P	1500	153	190	297	465	580	654	775	864	984	1084	1123	1247	1465	1687	1845	2214	2404
LBE1600P	1600	163	203	317	496	619	697	827	922	1050	1157	1198	1331	1563	1800	1968	2362	2565
LBE1660P	1660	169	211	329	515	642	723	858	956	1089	1200	1243	1380	1621	1867	2042	2451	2661

LE Range Cell performance

Available amperes at +20°C ± 5°C (+68°F ± 9°F)
Performance after prolonged float charge of fully charged cells

Final voltage: 1.10 V/cell

Cell type	C _c Ah	HOURS					MINUTES									SECONDS		
		10 h	8 h	5 h	3 h	2 h	90 min	60 min	45 min	30 min	20 min	15 min	10 min	5 min	1 min	30 s	5 s	1 s
LCE10P	10	1.00	1.23	1.88	2.67	3.36	3.88	4.64	5.20	5.85	6.50	6.90	7.77	9.07	11.6	13.3	17.4	19.8
LCE15P	15	1.50	1.84	2.82	4.00	5.04	5.82	6.96	7.80	8.78	9.75	10.4	11.7	13.6	17.4	20.0	26.2	29.8
LCE22P	22	2.20	2.70	4.14	5.87	7.39	8.54	10.2	11.4	12.9	14.3	15.2	17.1	20.0	25.6	29.3	38.4	43.6
LCE30P	30	3.00	3.68	5.64	8.01	10.1	11.6	13.9	15.6	17.6	19.5	20.7	23.3	27.2	34.9	40.0	52.3	59.5
LCE40P	40	4.00	4.90	7.53	10.7	13.4	15.5	18.6	20.8	23.4	26.0	27.6	31.1	36.3	46.5	53.4	69.8	79.3
LCE47P	47	4.70	5.76	8.84	12.5	15.8	18.2	21.8	24.4	27.5	30.5	32.4	36.5	42.6	54.7	62.7	82.0	93.2
LCE62P	62	6.20	7.60	11.7	16.5	20.8	24.1	28.8	32.2	36.3	40.3	42.8	48.2	56.2	72.1	82.7	108	123
LCE75P	75	7.43	9.10	14.0	20.0	24.9	28.3	33.6	35.9	40.4	44.5	45.0	50.0	58.3	73.4	82.1	103	115
LCE90P	90	8.91	10.9	16.8	24.0	29.8	33.9	40.3	43.1	48.5	53.4	54.0	59.9	70.0	88.0	98.5	123	139
LCE110P	110	10.9	13.3	20.5	29.4	36.5	41.5	49.3	52.6	59.3	65.2	66.0	73.3	85.5	108	120	150	169
LCE145P	145	14.4	17.6	27.0	38.7	48.1	54.7	65.0	69.4	78.2	86.0	87.0	96.6	113	142	159	198	223
LCE185P	185	18.3	22.4	34.4	49.4	61.3	69.8	82.9	88.5	99.7	110	111	123	144	181	202	253	285
LCE220P	220	21.8	26.7	41.0	58.7	72.9	83.0	98.6	105	119	130	132	147	171	215	241	301	339
LCE235P	235	23.5	28.8	44.2	61.3	75.9	84.8	102	112	119	129	141	157	162	215	235	286	313
LCE280P	280	28.0	34.3	52.7	73.0	90.4	101.0	121	134	142	153	168	186	194	257	280	341	373
LCE330P	330	33.0	40.4	62.1	86.1	107	119	143	158	168	181	198	220	228	302	330	402	440
LCE375P	375	37.5	45.9	70.6	97.8	121	135	162	179	191	205	225	250	259	344	374	457	500
LBE415P	415	41.5	50.8	78.1	108	134	150	179	199	211	227	249	276	287	380	414	505	554
LBE460P	460	46.0	56.4	86.6	120	149	166	199	220	234	252	276	306	318	422	459	560	614
LBE510P	510	51.0	62.5	96.0	133	165	184	220	244	259	279	306	340	353	467	509	621	680
LBE550P	550	55.0	67.4	103	143	178	198	238	263	280	301	330	366	380	504	549	670	734
LBE600P	600	60.0	73.5	113	157	194	216	259	287	305	328	360	400	415	550	599	731	800
LBE650P	650	65.0	79.6	122	170	210	235	281	311	330	356	390	433	449	596	649	791	867
LBE700P	700	70.0	85.8	132	183	226	253	302	335	356	383	420	466	484	642	699	852	934
LBE750P	750	75.0	91.9	141	196	242	271	324	359	381	410	450	500	518	687	749	913	1000
LBE830P	830	83.0	102	156	217	268	299	359	397	422	454	498	553	574	761	829	1011	1107
LBE925P	925	92.5	113	174	241	299	334	400	443	470	506	555	616	639	848	924	1126	1234
LBE1020P	1020	102	125	192	266	329	368	441	488	518	558	612	679	705	935	1019	1242	1360
LBE1100P	1100	110	135	207	287	355	397	475	526	559	602	660	733	760	1008	1099	1339	1467
LBE1200P	1200	120	147	226	313	388	433	518	574	610	657	720	799	829	1100	1198	1461	1601
LBE1300P	1300	130	159	245	339	420	469	562	622	661	711	780	866	899	1192	1298	1583	1734
LBE1400P	1400	140	172	263	365	452	505	605	670	711	766	840	932	968	1283	1398	1705	1867
LBE1500P	1500	150	184	282	391	485	541	648	718	762	821	900	999	1037	1375	1498	1826	2001
LBE1600P	1600	160	196	301	417	517	577	691	765	813	876	960	1066	1106	1466	1598	1948	2134
LBE1660P	1660	166	203	312	433	536	599	717	794	844	908	996	1106	1147	1521	1658	2021	2214

Cell performance **LE Range**

Available amperes at +20°C ± 5°C (+68°F ± 9°F)
Performance after prolonged float charge of fully charged cells

Final voltage: 1.14 V/cell

Cell type	C ₅ Ah	HOURS					MINUTES									SECONDS			
		10 h	8 h	5 h	3 h	2 h	90 min	60 min	45 min	30 min	20 min	15 min	10 min	5 min	1 min	30 s	5 s	1 s	
LCE10P	10	0.98	1.15	1.66	2.35	2.80	3.09	3.75	4.09	4.7	5.2	5.6	5.9	6.7	9.5	11.0	14.4	16.5	
LCE15P	15	1.47	1.73	2.48	3.52	4.20	4.64	5.63	6.14	7.0	7.8	8.4	8.8	10.1	14.3	16.5	21.6	24.8	
LCE22P	22	2.16	2.53	3.64	5.17	6.16	6.80	8.25	9.01	10.3	11.4	12.3	12.9	14.8	20.9	24.2	31.7	36.3	
LCE30P	30	2.94	3.46	4.97	7.05	8.40	9.27	11.3	12.3	14.0	15.6	16.7	17.6	20.2	28.5	33.0	43.3	49.6	
LCE40P	40	3.92	4.61	6.62	9.40	11.2	12.4	15.0	16.4	18.7	20.7	22.3	23.5	26.9	38.0	44.0	57.7	66.1	
LCE47P	47	4.61	5.41	7.78	11.0	13.2	14.5	17.6	19.2	22.0	24.4	26.2	27.6	31.6	44.7	51.8	67.8	77.6	
LCE62P	62	6.08	7.14	10.3	14.6	17.4	19.2	23.3	25.4	29.0	32.1	34.5	36.5	41.7	58.9	68.3	89.4	102	
LCE75P	75	7.20	8.46	12.3	17.2	20.4	22.4	25.9	28.1	31.8	35.6	35.7	41.0	44.1	60.0	66.4	85.1	95.9	
LCE90P	90	8.64	10.2	14.7	20.6	24.5	26.9	31.1	33.7	38.1	42.8	42.8	49.1	52.9	72.0	79.6	102	115	
LCE110P	110	10.6	12.4	18.0	25.2	29.9	32.9	38.0	41.2	46.6	52.3	52.4	60.1	64.7	88.0	97.3	125	141	
LCE145P	145	13.9	16.4	23.7	33.2	39.4	43.3	50.0	54.4	61.4	68.9	69.0	79.2	85.3	116	128	164	185	
LCE185P	185	17.8	20.9	30.3	42.4	50.3	55.3	63.8	69.4	78.3	87.9	88.1	101	109	148	164	210	236	
LCE220P	220	21.1	24.8	36.0	50.4	59.8	65.8	75.9	82.5	93.1	105	105	120	129	176	195	249	281	
LCE235P	235	23.0	27.1	38.9	53.2	61.1	66.7	77.6	83.5	96.1	102	105	118	138	176	193	239	265	
LCE280P	280	27.4	32.3	46.4	63.3	72.8	79.4	92.4	99.5	114	121	125	141	165	209	229	284	316	
LCE330P	330	32.3	38.0	54.6	74.6	85.8	93.6	109	117	135	143	148	166	194	247	270	335	372	
LCE375P	375	36.8	43.2	62.1	84.8	97.5	106.4	124	133	153	162	168	189	221	280	307	381	423	
LBE415P	415	40.7	47.8	68.7	93.9	108	118	137	147	170	179	186	209	244	310	340	422	468	
LBE460P	460	45.1	53.0	76.2	104	120	131	152	163	188	199	206	232	270	344	377	467	519	
LBE510P	510	50.0	58.8	84.5	115	133	145	168	181	208	220	228	257	300	381	418	518	575	
LBE550P	550	53.9	63.4	91.1	124	143	156	182	195	225	238	246	277	323	411	451	559	620	
LBE600P	600	58.8	69.1	99.4	136	156	170	198	213	245	259	269	302	353	448	492	610	676	
LBE650P	650	63.7	74.9	108	147	169	184	215	231	266	281	291	328	382	486	533	660	733	
LBE700P	700	68.6	80.6	116	158	182	199	231	249	286	302	314	353	412	523	574	711	789	
LBE750P	750	73.5	86.4	124	170	195	213	248	266	307	324	336	378	441	560	615	762	846	
LBE830P	830	81.3	95.6	137	188	216	235	274	295	339	359	372	418	488	620	680	843	936	
LBE925P	925	90.7	107	153	209	241	262	305	329	378	400	414	466	544	691	758	940	1043	
LBE1020P	1020	100	118	169	231	265	289	337	362	417	441	457	514	600	762	836	1036	1150	
LBE1100P	1100	108	127	182	249	286	312	363	391	450	475	493	554	647	822	901	1118	1240	
LBE1200P	1200	118	138	199	271	312	340	396	426	491	518	538	605	706	897	983	1219	1353	
LBE1300P	1300	127	150	215	294	338	369	429	462	531	562	582	655	764	971	1065	1321	1466	
LBE1400P	1400	137	161	232	317	364	397	462	497	572	605	627	706	823	1046	1147	1422	1578	
LBE1500P	1500	147	173	248	339	390	426	495	533	613	648	672	756	882	1121	1229	1524	1691	
LBE1600P	1600	157	184	265	362	416	454	528	568	654	691	717	806	941	1196	1311	1626	1804	
LBE1660P	1660	163	191	275	375	432	471	548	590	679	717	744	837	976	1240	1360	1687	1872	

M Range

Cell dimensions and internal resistance

M cells are normally supplied as single cells, taped together into blocks or assembled in steel crates.

Cell type	Capacity at the 5hr rate (Ah)	Volume of liquid electrolyte above plates (cc)	Approx. weight per cell		Overall height		Width per cell		Length per cell		Internal resistance (mOhm)	Electrolyte height between Min - Max (mm)
			(kg)	(lbs)	(mm)	H (ins)	(mm)	W (ins)	(mm)	L (ins)		
MC9P	9	146	1.6	3.6	275	10.83	121	4.76	42	1.65	6.89	35
MC14P	14	146	1.7	3.7	275	10.83	121	4.76	42	1.65	4.43	35
MC22P	22	143	1.9	4.2	275	10.83	121	4.76	42	1.65	2.82	35
MC31P	31	140	2.1	4.6	275	10.83	121	4.76	42	1.65	2.00	35
MC39P	39	235	3.1	6.8	275	10.83	121	4.76	66	2.60	1.59	35
MC47P	47	232	3.3	7.2	275	10.83	121	4.76	66	2.60	1.32	35
MC55P	55	230	3.5	7.6	275	10.83	121	4.76	66	2.60	1.13	35
MC70P	70	552	6.3	13.8	358	14.09	192	7.56	68	2.68	1.11	35
MC90P	90	546	6.6	14.4	358	14.09	192	7.56	68	2.68	0.87	50
MC110P	110	539	7.2	15.9	358	14.09	192	7.56	68	2.68	0.71	50
MC130P	130	532	7.7	16.9	358	14.09	192	7.56	68	2.68	0.60	50
MC145P	145	758	9.9	21.7	358	14.09	192	7.56	93	3.66	0.54	50
MC165P	165	751	10.3	22.7	358	14.09	192	7.56	93	3.66	0.47	50
MC185P	185	744	10.7	23.5	358	14.09	192	7.56	93	3.66	0.42	50
MC215P	215	751	13.1	28.8	414	16.30	192	7.56	93	3.66	0.40	50
MC240P	240	744	13.5	29.7	414	16.30	192	7.56	93	3.66	0.36	50
MC285P	285	1005	17.2	38.0	414	16.30	192	7.56	122	4.80	0.30	50
MC310P	310	996	17.7	38.9	414	16.30	192	7.56	122	4.80	0.28	50
MC335P	335	989	18.2	40.1	414	16.30	192	7.56	122	4.80	0.26	50
MB370P	369	1200	19.5	42.9	405	15.94	195	7.68	159	6.26	0.23	50
MB390P	392	1300	21.0	46.2	405	15.94	195	7.68	171	6.73	0.22	50
MB415P	415	1400	23.0	50.6	405	15.94	195	7.68	183	7.20	0.21	50
MB440P	438	1400	23.5	51.7	405	15.94	195	7.68	183	7.20	0.20	50
MB460P	461	1400	24.0	52.8	405	15.94	195	7.68	183	7.20	0.19	50
MB505P	505	1600	27.5	60.5	405	15.94	195	7.68	213	8.39	0.17	50
MB555P	555	1800	30.0	66.0	405	15.94	195	7.68	232	9.13	0.15	50
MB625P	625	2100	34.5	75.9	405	15.94	195	7.68	268	10.55	0.14	50
MB690P	690	2100	36.0	79.2	405	15.94	195	7.68	268	10.55	0.12	50
MB740P	740	2400	40.0	88.0	405	15.94	195	7.68	304	11.97	0.12	50
MB830P	830	2800	46.0	101.2	405	15.94	195	7.68	352	13.86	0.10	50
MB920P	920	2800	48.0	105.6	405	15.94	195	7.68	352	13.86	0.09	50
MB965P	965	3000	50.5	111.1	405	15.94	195	7.68	372	14.65	0.09	50
MB1040P	1040	3500	57.5	126.5	405	15.94	195	7.68	437	17.20	0.08	50
MB1150P	1150	3500	60.0	132.0	405	15.94	195	7.68	437	17.20	0.07	50
MB1220P	1220	4100	67.5	148.5	405	15.94	195	7.68	510	20.08	0.07	50
MB1390P	1390	4200	72.0	158.4	405	15.94	195	7.68	522	20.55	0.06	50

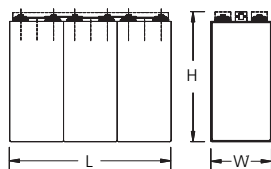
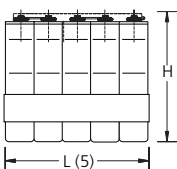

MC9P - MC335P
Taped block length =
cell length x no of cells + 2mm/0.1 in.

MB370P - MB1390P

Cell connection bolt per pole:	MB370P to MB460P: 2 x M10
	MB505P to MB690P: 3 x M10
MC9P to MC55P: M6	MB740P to MB920P: 4 x M10
MC70P & MC90P: M8	MB965P: 6 x M10
MC110P to MC240P: M10	MB1040P & MB1150P: 5 x M10
MC285P to MC335P: 2 x M10	MB1120P to MB1390P: 6 x M10

Cell performance

M Range

Available amperes at +20°C ± 5°C (+68°F ± 9°F)
Performance after prolonged float charge of fully charged cells

Final voltage: 1.00 V/cell

Cell type	C ₅ Ah	HOURS				MINUTES								SECONDS		
		8 h	5 h	3 h	2 h	90 min	60 min	30 min	20 min	15 min	10 min	5 min	1 min	30 s	5 s	1 s
MC9P	9	1.13	1.80	2.94	4.29	5.15	6.66	9.00	10.6	11.5	13.0	15.9	22.7	25.6	30.8	32.6
MC14P	14	1.76	2.80	4.58	6.68	8.02	10.4	14.0	16.4	17.9	20.3	24.7	35.3	39.8	47.9	50.7
MC22P	22	2.77	4.40	7.19	10.5	12.6	16.3	22.0	25.8	28.2	31.8	38.9	55.4	62.5	75.3	79.7
MC31P	31	3.91	6.20	10.1	14.8	17.8	22.9	31.0	36.3	39.7	44.9	54.8	78.1	88.1	106	112
MC39P	39	4.91	7.80	12.8	18.6	22.3	28.8	39.0	45.7	49.9	56.4	68.9	98.2	111	134	141
MC47P	47	5.92	9.40	15.4	22.4	26.9	34.8	47.0	55.1	60.2	68.0	83.0	118	134	161	170
MC55P	55	6.93	11.0	18.0	26.2	31.5	40.7	55.0	64.5	70.4	79.6	97.2	139	156	188	199
MC70P	70	8.82	14.0	22.9	33.5	40.4	52.4	74.6	87.3	95.8	109	133	188	213	258	276
MC90P	90	11.3	18.0	29.4	43.0	51.9	67.3	95.9	112	123	140	171	241	274	332	354
MC110P	110	13.9	22.0	36.0	52.6	63.4	82.3	117	137	150	171	209	295	334	406	433
MC130P	130	16.4	26.0	42.5	62.1	75.0	97.2	139	162	178	202	247	349	395	480	512
MC145P	145	18.3	29.0	47.4	69.3	83.6	108	155	181	198	225	275	389	441	535	571
MC165P	165	20.8	33.0	54.0	78.9	95.2	123	176	206	226	256	313	442	502	609	650
MC185P	185	23.3	37.0	60.5	88.4	107	138	197	231	253	287	351	496	562	683	728
MC215P	215	27.1	43.0	70.3	103	124	161	228	266	291	329	397	554	620	739	782
MC240P	240	30.2	48.0	78.5	115	138	180	254	297	325	367	444	619	692	825	873
MC285P	285	35.9	57.0	93.2	136	164	213	302	353	386	436	527	735	821	979	1036
MC310P	310	39.1	62.0	101	148	179	232	328	384	419	474	573	799	893	1065	1127
MC335P	335	42.2	67.0	110	160	193	251	354	415	453	512	619	863	965	1151	1218
MB370P	369	46.5	73.8	121	176	213	276	390	457	499	564	682	951	1063	1268	1342
MB390P	392	49.4	78.4	128	187	226	293	415	485	530	599	725	1010	1130	1347	1425
MB415P	415	52.3	83.0	136	198	239	310	439	514	562	635	767	1070	1196	1426	1509
MB440P	438	55.2	87.6	143	209	253	328	463	542	593	670	810	1129	1262	1505	1593
MB460P	461	58.1	92.2	151	220	266	345	488	571	624	705	852	1188	1329	1584	1676
MB505P	505	63.6	101	165	241	291	378	534	625	683	772	933	1302	1455	1735	1836
MB555P	555	69.9	111	181	265	320	415	587	687	751	849	1026	1430	1599	1907	2018
MB625P	625	78.7	125	204	299	360	467	661	774	846	956	1155	1611	1801	2148	2273
MB690P	690	86.9	138	226	330	398	516	730	854	934	1055	1275	1778	1988	2371	2509
MB740P	740	93.2	148	242	354	427	553	783	916	1001	1131	1368	1907	2133	2543	2691
MB830P	830	105	166	271	397	479	621	878	1027	1123	1269	1534	2139	2392	2852	3018
MB920P	920	116	184	301	440	531	688	974	1139	1245	1407	1701	2371	2651	3162	3345
MB965P	965	122	193	316	461	557	722	1021	1194	1306	1476	1784	2487	2781	3316	3509
MB1040P	1040	131	208	340	497	600	778	1101	1287	1407	1590	1922	2680	2997	3574	3782
MB1150P	1150	145	230	376	550	663	860	1217	1423	1556	1758	2126	2964	3314	3952	4182
MB1220P	1220	154	244	399	583	704	912	1291	1510	1651	1865	2255	3144	3516	4192	4436
MB1390P	1390	175	278	455	664	802	1040	1471	1720	1881	2125	2569	3582	4006	4777	5055

M Range Cell performance

Available amperes at +20°C ± 5°C (+68°F ± 9°F)
Performance after prolonged float charge of fully charged cells

Final voltage: 1.05 V/cell

Cell type	C ₅ Ah	HOURS				MINUTES								SECONDS		
		8 h	5 h	3 h	2 h	90 min	60 min	30 min	20 min	15 min	10 min	5 min	1 min	30 s	5 s	1 s
MC9P	9	1.13	1.78	2.90	3.78	4.53	5.83	7.65	8.69	9.65	11.0	13.2	18.6	21.1	25.0	26.9
MC14P	14	1.75	2.77	4.51	5.87	7.05	9.07	11.9	13.5	15.0	17.1	20.5	28.9	32.8	38.9	41.9
MC22P	22	2.75	4.36	7.08	9.23	11.1	14.2	18.7	21.2	23.6	26.9	32.2	45.4	51.5	61.1	65.9
MC31P	31	3.88	6.14	9.98	13.0	15.6	20.1	26.4	29.9	33.2	37.9	45.3	63.9	72.6	86.1	92.8
MC39P	39	4.88	7.72	12.6	16.4	19.6	25.3	33.2	37.6	41.8	47.7	57.0	80.4	91.3	108	117
MC47P	47	5.88	9.31	15.1	19.7	23.7	30.4	40.0	45.4	50.4	57.5	68.7	96.9	110	131	141
MC55P	55	6.88	10.9	17.7	23.1	27.7	35.6	46.8	53.1	58.9	67.3	80.4	113	129	153	165
MC70P	70	8.75	13.9	22.6	29.5	35.7	47.1	63.3	71.8	79.3	91.5	110	155	175	211	227
MC90P	90	11.3	17.8	29.1	37.9	45.9	60.5	81.4	92.3	102	118	141	199	226	272	291
MC110P	110	13.8	21.8	35.5	46.3	56.1	74.0	99.5	113	125	144	172	243	276	332	356
MC130P	130	16.3	25.7	42.0	54.8	66.3	87.4	118	133	147	170	204	288	326	393	421
MC145P	145	18.1	28.7	46.8	61.1	73.9	97.5	131	149	164	190	227	321	363	438	469
MC165P	165	20.6	32.7	53.3	69.5	84.1	111	149	169	187	216	259	365	414	498	534
MC185P	185	23.1	36.6	59.8	77.9	94.3	124	167	190	210	242	290	409	464	559	599
MC215P	215	26.9	42.6	69.4	90.6	110	145	193	219	242	275	326	452	508	599	646
MC240P	240	30.0	47.5	77.5	101	122	161	215	244	270	307	364	504	567	669	721
MC285P	285	35.6	56.4	92.1	120	145	192	256	290	321	364	432	599	674	794	856
MC310P	310	38.8	61.4	100	131	158	208	278	316	349	396	470	651	733	864	931
MC335P	335	41.9	66.3	108	141	171	225	300	341	377	428	508	704	792	933	1006
MB370P	369	46.1	73.1	119	155	188	248	331	376	415	471	559	775	872	1028	1108
MB390P	392	49.0	77.6	127	165	200	264	352	399	441	501	594	824	927	1092	1177
MB415P	415	51.9	82.2	134	175	212	279	372	423	467	530	629	872	981	1156	1246
MB440P	438	54.8	86.7	141	184	223	295	393	446	493	559	664	920	1035	1220	1315
MB460P	461	57.6	91.3	149	194	235	310	413	469	519	589	698	968	1090	1284	1384
MB505P	505	63.1	100.0	163	213	258	340	453	514	568	645	765	1061	1194	1407	1517
MB555P	555	69.4	110	179	234	283	373	498	565	624	709	841	1166	1312	1546	1667
MB625P	625	78.1	124	202	263	319	420	561	636	703	798	947	1313	1478	1741	1877
MB690P	690	86.3	137	223	291	352	464	619	703	776	881	1045	1450	1631	1922	2072
MB740P	740	92.5	147	239	312	377	498	664	754	832	945	1121	1555	1749	2061	2222
MB830P	830	104	164	268	350	423	558	744	845	934	1060	1258	1744	1962	2312	2492
MB920P	920	115	182	297	388	469	619	825	937	1035	1175	1394	1933	2175	2563	2763
MB965P	965	121	191	312	406	492	649	865	983	1085	1232	1462	2027	2281	2688	2898
MB1040P	1040	130	206	336	438	530	699	933	1059	1170	1328	1576	2185	2459	2897	3123
MB1150P	1150	144	228	371	484	586	773	1031	1171	1294	1469	1742	2416	2719	3203	3453
MB1220P	1220	153	242	394	514	622	820	1094	1242	1372	1558	1848	2563	2884	3398	3664
MB1390P	1390	174	275	449	586	709	935	1247	1415	1564	1775	2106	2920	3286	3872	4174

Cell performance

M Range

Available amperes at +20°C ± 5°C (+68°F ± 9°F)
Performance after prolonged float charge of fully charged cells

Final voltage: 1.10 V/cell

Cell type	C ₅ Ah	HOURS				MINUTES								SECONDS		
		8 h	5 h	3 h	2 h	90 min	60 min	30 min	20 min	15 min	10 min	5 min	1 min	30 s	5 s	1 s
MC9P	9	1.11	1.76	2.61	3.35	3.98	4.85	6.26	7.23	7.84	8.81	10.7	15.2	16.9	20.1	21.4
MC14P	14	1.72	2.73	4.06	5.21	6.18	7.55	9.74	11.2	12.2	13.7	16.6	23.6	26.4	31.3	33.3
MC22P	22	2.71	4.29	6.38	8.19	9.72	11.9	15.3	17.7	19.2	21.5	26.1	37.0	41.4	49.2	52.4
MC31P	31	3.81	6.05	9.00	11.5	13.7	16.7	21.6	24.9	27.0	30.4	36.8	52.2	58.4	69.4	73.8
MC39P	39	4.80	7.61	11.3	14.5	17.2	21.0	27.1	31.3	34.0	38.2	46.3	65.7	73.4	87.2	92.9
MC47P	47	5.78	9.17	13.6	17.5	20.8	25.3	32.7	37.8	40.9	46.0	55.8	79.1	88.5	105	112
MC55P	55	6.77	10.7	16.0	20.5	24.3	29.6	38.2	44.2	47.9	53.9	65.2	92.6	104	123	131
MC70P	70	8.61	13.7	20.4	26.3	31.6	39.3	51.3	59.8	65.0	73.1	88.5	125	142	168	194
MC90P	90	11.1	17.6	26.2	33.8	40.6	50.6	65.9	76.9	83.6	93.9	114	161	182	216	249
MC110P	110	13.5	21.5	32.0	41.3	49.6	61.8	80.6	93.9	102	115	139	197	223	264	305
MC130P	130	16.0	25.4	37.8	48.8	58.7	73.1	95.2	111	121	136	164	233	263	312	360
MC145P	145	17.8	28.3	42.2	54.4	65.4	81.5	106	124	135	151	183	259	294	348	402
MC165P	165	20.3	32.2	48.0	62.0	74.5	92.7	121	141	153	172	209	295	334	396	457
MC185P	185	22.8	36.1	53.9	69.5	83.5	104	136	158	172	193	234	331	374	444	512
MC215P	215	26.4	41.9	62.6	80.7	97.0	121	156	181	195	220	263	366	409	482	512
MC240P	240	29.5	46.8	69.9	90.1	108	135	174	202	218	245	293	409	456	538	571
MC285P	285	35.1	55.6	83.0	107	129	160	207	239	259	291	348	486	542	639	679
MC310P	310	38.1	60.5	90.2	116	140	174	225	260	281	317	379	528	589	695	738
MC335P	335	41.2	65.3	97.5	126	151	188	243	281	304	343	409	571	637	751	798
MB370P	369	45.4	72.0	107	139	167	207	268	310	335	377	451	629	702	827	879
MB390P	392	48.2	76.4	114	147	177	220	284	329	356	401	479	668	745	879	933
MB415P	415	51.0	80.9	121	156	187	233	301	348	377	424	507	707	789	930	988
MB440P	438	53.9	85.4	128	164	198	246	318	368	397	448	535	746	833	982	1043
MB460P	461	56.7	89.9	134	173	208	259	334	387	418	471	563	785	876	1034	1098
MB505P	505	62.1	98.5	147	190	228	284	366	424	458	516	617	860	960	1132	1202
MB555P	555	68.3	108	162	208	250	312	402	466	504	567	678	945	1055	1244	1321
MB625P	625	76.9	122	182	235	282	351	453	525	567	639	763	1065	1188	1401	1488
MB690P	690	84.9	135	201	259	311	388	500	579	626	706	842	1175	1312	1547	1643
MB740P	740	91.0	144	215	278	334	416	537	621	672	757	904	1261	1407	1659	1762
MB830P	830	102	162	242	312	375	467	602	697	753	849	1013	1414	1578	1861	1976
MB920P	920	113	179	268	345	415	517	667	772	835	941	1123	1567	1749	2063	2190
MB965P	965	119	188	281	362	435	542	700	810	876	987	1178	1644	1835	2164	2298
MB1040P	1040	128	203	303	391	469	585	754	873	944	1063	1270	1772	1977	2332	2476
MB1150P	1150	141	224	335	432	519	646	834	966	1044	1176	1404	1959	2186	2578	2738
MB1220P	1220	150	238	355	458	551	686	885	1024	1107	1247	1490	2078	2319	2735	2905
MB1390P	1390	171	271	405	522	627	781	1008	1167	1261	1421	1697	2368	2643	3117	3310

M Range Cell performance

Available amperes at +20°C ± 5°C (+68°F ± 9°F)
Performance after prolonged float charge of fully charged cells

Final voltage: 1.14 V/cell

Cell type	C ₅ Ah	HOURS				MINUTES								SECONDS		
		8 h	5 h	3 h	2 h	90 min	60 min	30 min	20 min	15 min	10 min	5 min	1 min	30 s	5 s	1 s
MC9P	9	1.08	1.69	2.29	2.87	3.37	3.89	5.03	5.75	6.27	7.18	8.62	12.2	13.7	15.9	16.5
MC14P	14	1.68	2.63	3.56	4.46	5.25	6.05	7.83	8.95	9.76	11.2	13.4	18.9	21.3	24.8	25.6
MC22P	22	2.64	4.14	5.59	7.01	8.25	9.50	12.3	14.1	15.3	17.5	21.1	29.8	33.4	38.9	40.2
MC31P	31	3.72	5.83	7.88	9.88	11.6	13.4	17.3	19.8	21.6	24.7	29.7	41.9	47.1	54.9	56.7
MC39P	39	4.68	7.33	9.91	12.4	14.6	16.8	21.8	24.9	27.2	31.1	37.4	52.8	59.3	69.0	71.3
MC47P	47	5.64	8.84	11.9	15.0	17.6	20.3	26.3	30.1	32.8	37.5	45.0	63.6	71.4	83.2	85.9
MC55P	55	6.60	10.3	14.0	17.5	20.6	23.8	30.7	35.2	38.3	43.9	52.7	74.4	83.6	97.3	101
MC70P	70	8.40	13.2	17.8	22.7	27.0	31.7	41.1	47.1	52.0	59.1	71.3	102	114	134	139
MC90P	90	10.8	16.9	22.9	29.2	34.8	40.8	52.8	60.6	66.9	75.9	91.6	131	147	172	179
MC110P	110	13.2	20.7	28.0	35.7	42.5	49.9	64.5	74.1	81.8	92.8	112	161	180	210	219
MC130P	130	15.6	24.4	33.1	42.1	50.2	59.0	76.2	87.5	96.7	110	132	190	212	248	258
MC145P	145	17.4	27.3	37.0	47.0	56.0	65.8	85.0	97.6	108	122	148	212	237	277	288
MC165P	165	19.8	31.0	42.1	53.5	63.7	74.8	96.8	111	123	139	168	241	270	315	328
MC185P	185	22.2	34.8	47.2	60.0	71.5	83.9	109	125	138	156	188	270	302	353	368
MC215P	215	25.8	40.4	54.8	69.5	82.9	97.5	125	143	156	177	212	297	330	381	392
MC240P	240	28.8	45.1	61.2	77.6	92.5	109	139	160	174	198	236	331	368	425	438
MC285P	285	34.2	53.6	72.7	92.2	110	129	165	190	206	235	281	393	437	504	520
MC310P	310	37.2	58.3	79.0	100	120	141	180	207	224	256	305	428	475	549	566
MC335P	335	40.2	63.0	85.4	108	129	152	194	223	242	276	330	462	514	593	611
MB370P	369	44.3	69.4	94.1	119	142	167	214	246	267	304	364	509	566	653	673
MB390P	392	47.0	73.7	100	127	151	178	227	261	284	323	386	541	601	694	715
MB415P	415	49.8	78.0	106	134	160	188	241	276	300	342	409	572	637	735	757
MB440P	438	52.6	82.3	112	142	169	199	254	292	317	361	432	604	672	775	799
MB460P	461	55.3	86.7	118	149	178	209	267	307	334	380	454	636	707	816	841
MB505P	505	60.6	94.9	129	163	195	229	293	336	365	416	498	697	775	894	922
MB555P	555	66.6	104	142	179	214	252	322	370	402	458	547	766	851	982	1013
MB625P	625	75.0	118	159	202	241	283	362	416	452	515	616	862	959	1106	1141
MB690P	690	82.8	130	176	223	266	313	400	460	499	569	680	952	1058	1221	1259
MB740P	740	88.8	139	189	239	285	336	429	493	535	610	729	1021	1135	1310	1350
MB830P	830	99.6	156	212	268	320	376	481	553	601	684	818	1145	1273	1469	1515
MB920P	920	110	173	235	298	355	417	533	613	666	758	906	1269	1411	1628	1679
MB965P	965	116	181	246	312	372	438	559	643	698	796	951	1331	1480	1708	1761
MB1040P	1040	125	196	265	336	401	472	603	693	753	857	1025	1434	1595	1841	1898
MB1150P	1150	138	216	293	372	443	522	667	766	832	948	1133	1586	1764	2035	2099
MB1220P	1220	146	229	311	395	470	553	707	813	883	1006	1202	1683	1871	2159	2226
MB1390P	1390	167	261	354	450	536	630	806	926	1006	1146	1369	1917	2132	2460	2536

Cell dimensions and internal resistance

H Range

H cells are normally supplied as single cells, taped together into blocks or assembled in steel crates.

Cell type	Capacity at the 5hr rate (Ah)	Volume of liquid electrolyte above plates (cc)	Approx. weight per cell		Overall height		Width per cell		Length per cell		Internal resistance (mOhm)	Electrolyte height between Min - Max (mm)
			(kg)	(lb)	(mm)	H (ins)	(mm)	W (ins)	(mm)	L (ins)		
HC9P	9	143	1.8	3.9	275	10.83	121	4.76	42	1.65	3.33	35
HC12P	12	140	1.9	4.2	275	10.83	121	4.76	42	1.65	2.50	35
HC17P	17	138	2.1	4.5	275	10.83	121	4.76	42	1.65	1.76	35
HC21P	21	232	3.0	6.6	275	10.83	121	4.76	66	2.60	1.43	35
HC25P	25	230	3.2	6.9	275	10.83	121	4.76	66	2.60	1.20	35
HC29P	29	227	3.3	7.3	275	10.83	121	4.76	66	2.60	1.03	35
HC34P	34	224	3.5	7.6	275	10.83	121	4.76	66	2.60	0.88	35
HC40P	40	546	6.2	13.7	358	14.09	192	7.56	68	2.68	0.98	50
HC50P	50	539	6.6	14.5	358	14.09	192	7.56	68	2.68	0.78	50
HC60P	60	532	7.0	15.4	358	14.09	192	7.56	68	2.68	0.65	50
HC70P	70	525	7.4	16.2	358	14.09	192	7.56	68	2.68	0.56	50
HC80P	80	518	7.7	17.0	358	14.09	192	7.56	68	2.68	0.49	50
HC90P	90	744	9.8	21.6	358	14.09	192	7.56	93	3.66	0.43	50
HC100P	100	737	10.1	22.2	358	14.09	192	7.56	93	3.66	0.39	50
HC110P	110	731	10.5	23.1	358	14.09	192	7.56	93	3.66	0.35	50
HC120P	120	724	10.8	23.8	358	14.09	192	7.56	93	3.66	0.33	50
HC130P	130	737	12.8	28.3	414	16.30	192	7.56	93	3.66	0.33	50
HC145P	145	731	13.2	29.0	414	16.30	192	7.56	93	3.66	0.30	50
HC155P	155	724	13.5	29.8	414	16.30	192	7.56	93	3.66	0.28	50
HC185P	185	976	17.5	38.5	414	16.30	192	7.56	122	4.80	0.23	50
HC210P	210	962	18.2	40.0	414	16.30	192	7.56	122	4.80	0.20	50
HB230P	230	1200	20.0	44.0	405	15.94	195	7.68	159	6.26	0.19	50
HB255P	256	1200	21.0	46.2	405	15.94	195	7.68	159	6.26	0.17	50
HB280P	281	1400	23.5	51.7	405	15.94	195	7.68	183	7.20	0.15	50
HB305P	307	1400	24.5	53.9	405	15.94	195	7.68	183	7.20	0.14	50
HB345P	345	1800	29.5	64.9	405	15.94	195	7.68	232	9.13	0.12	50
HB385P	383	1700	31.0	68.2	405	15.94	195	7.68	232	9.13	0.11	50
HB420P	422	2100	34.5	75.9	405	15.94	195	7.68	268	10.55	0.10	50
HB460P	460	2100	36.0	79.2	405	15.94	195	7.68	268	10.55	0.09	50
HB510P	510	2300	42.0	92.4	405	15.94	195	7.68	304	11.97	0.08	50
HB560P	560	2800	46.0	101.2	405	15.94	195	7.68	352	13.86	0.08	50
HB615P	615	2800	48.0	105.6	405	15.94	195	7.68	352	13.86	0.07	50
HB640P	640	2900	52.5	115.5	405	15.94	195	7.68	377	14.84	0.07	50
HB705P	705	3500	57.5	126.5	405	15.94	195	7.68	437	17.20	0.06	50
HB765P	765	3500	60.0	132.0	405	15.94	195	7.68	437	17.20	0.06	50
HB865P	865	4000	68.5	150.7	405	15.94	195	7.68	497	19.57	0.05	50
HB920P	920	4200	72.0	158.4	405	15.94	195	7.68	522	20.55	0.05	50

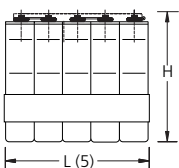

HC9P - HC210P
Taped block length =
cell length x no of cells + 2mm/0.1 in.

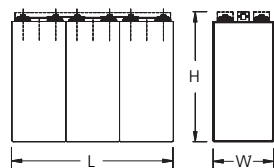

HB230P - HB920P

Cell connection bolt per pole:	HB230P to HB305P:	2 x M10	
HC9P to HC34P:	M6	HB345P to HB460P:	3 x M10
HC40P & HC50P:	M8	HB510P to HB615P:	4 x M10
HC60P to HC155P:	M10	HB640P to HB765P:	5 x M10
HC185P & HC210P:	2 x M10	HB865P & HB920P:	6 x M10

H Range Cell performance

Available amperes at +20°C ± 5°C (+68°F ± 9°F)
 Performance after prolonged float charge of fully charged cells

Final voltage: 1.00 V/cell

Cell type	C ₅ Ah	HOURS				MINUTES								SECONDS		
		8 h	5 h	3 h	2 h	90 min	60 min	30 min	20 min	15 min	10 min	5 min	1 min	30 s	5 s	1 s
HC9P	9	1.13	1.80	2.96	4.39	5.78	8.46	15.3	20.4	23.0	26.2	31.6	46.6	52.6	66.7	70.9
HC12P	12	1.50	2.40	3.95	5.86	7.70	11.3	20.4	27.2	30.7	34.9	42.1	62.2	70.2	88.9	94.5
HC17P	17	2.13	3.40	5.59	8.30	10.9	16.0	28.9	38.5	43.5	49.4	59.6	88.1	99.4	126	134
HC21P	21	2.63	4.20	6.91	10.2	13.5	19.7	35.7	47.6	53.7	61.0	73.7	109	123	156	165
HC25P	25	3.13	5.00	8.22	12.2	16.0	23.5	42.5	56.7	63.9	72.7	87.7	130	146	185	197
HC29P	29	3.63	5.80	9.54	14.2	18.6	27.3	49.3	65.8	74.2	84.3	102	150	170	215	228
HC34P	34	4.25	6.80	11.2	16.6	21.8	32.0	57.8	77.1	87.0	98.8	119	176	199	252	268
HC40P	40	5.00	8.00	13.2	19.5	25.7	37.6	68.8	92.8	106	120	145	206	235	296	325
HC50P	50	6.25	10.0	16.5	24.4	32.2	47.0	86.1	116	132	150	181	258	294	370	407
HC60P	60	7.50	12.0	19.7	29.3	38.6	56.4	103	139	158	180	217	309	353	444	488
HC70P	70	8.75	14.0	23.0	34.2	45.0	65.8	120	162	185	210	254	361	412	519	569
HC80P	80	10.0	16.0	26.3	39.0	51.4	75.2	138	186	211	240	290	412	471	593	650
HC90P	90	11.3	18.0	29.6	43.9	57.9	84.6	155	209	237	270	326	464	529	667	732
HC100P	100	12.5	20.0	32.9	48.8	64.3	94.0	172	232	264	300	362	515	588	741	813
HC110P	110	13.8	22.0	36.2	53.7	70.7	103	189	255	290	330	399	567	647	815	894
HC120P	120	15.0	24.0	39.5	58.6	77.2	113	207	278	317	360	435	619	706	889	976
HC130P	130	16.3	26.0	42.8	63.4	83.5	122	222	298	335	377	445	615	694	844	897
HC145P	145	18.1	29.0	47.7	70.8	93.1	136	247	333	374	421	496	686	774	941	1001
HC155P	155	19.4	31.0	51.0	75.6	99.5	146	265	355	399	450	531	733	827	1006	1070
HC185P	185	23.1	37.0	60.9	90.3	119	174	316	424	477	537	633	875	987	1200	1277
HC210P	210	26.3	42.0	69.1	102	135	197	358	482	541	609	719	993	1121	1363	1449
HB230P	230	28.8	46.0	75.7	112	148	216	393	528	593	668	788	1088	1228	1493	1588
HB255P	255	31.9	51.0	83.9	124	164	240	435	585	657	740	873	1206	1361	1655	1760
HB280P	280	35.0	56.0	92.1	137	180	263	478	642	721	813	959	1324	1494	1817	1933
HB305P	305	38.1	61.0	100	149	196	287	520	700	786	885	1044	1442	1628	1979	2105
HB345P	345	43.1	69.0	114	168	221	324	589	791	889	1001	1181	1631	1841	2239	2381
HB385P	385	48.1	77.0	127	188	247	362	657	883	992	1117	1318	1820	2055	2498	2657
HB420P	420	52.5	84.0	138	205	270	395	717	963	1082	1219	1438	1986	2242	2725	2899
HB460P	460	57.5	92.0	151	224	295	432	785	1055	1185	1335	1575	2175	2455	2985	3175
HB510P	510	63.8	102	168	249	327	479	870	1170	1314	1480	1746	2411	2722	3309	3520
HB560P	560	70.0	112	184	273	360	526	956	1284	1443	1625	1917	2648	2989	3634	3865
HB615P	615	76.9	123	202	300	395	578	1050	1410	1584	1785	2106	2908	3282	3991	4245
HB640P	640	80.0	128	211	312	411	602	1092	1468	1649	1857	2191	3026	3416	4153	4417
HB705P	705	88.1	141	232	344	453	663	1203	1617	1816	2046	2414	3333	3763	4575	4866
HB765P	765	95.6	153	252	373	491	719	1305	1755	1971	2220	2619	3617	4083	4964	5280
HB865P	865	108	173	285	422	555	813	1476	1984	2228	2510	2962	4090	4616	5613	5970
HB920P	920	115	184	303	449	591	865	1570	2110	2370	2670	3150	4350	4910	5970	6350

Cell performance

H Range

Available amperes at +20°C ± 5°C (+68°F ± 9°F)
Performance after prolonged float charge of fully charged cells

Final voltage: 1.05 V/cell

Cell type	C ₅ Ah	HOURS				MINUTES								SECONDS		
		8 h	5 h	3 h	2 h	90 min	60 min	30 min	20 min	15 min	10 min	5 min	1 min	30 s	5 s	1 s
HC9P	9	1.12	1.77	2.92	4.30	5.65	8.19	14.5	17.4	19.2	21.7	25.9	38.5	45.2	55.2	59.6
HC12P	12	1.49	2.36	3.89	5.74	7.54	10.9	19.3	23.3	25.6	28.9	34.5	51.3	60.3	73.6	79.5
HC17P	17	2.11	3.35	5.51	8.13	10.7	15.5	27.4	32.9	36.2	41.0	48.9	72.6	85.4	104	113
HC21P	21	2.60	4.14	6.80	10.0	13.2	19.1	33.8	40.7	44.8	50.6	60.3	89.7	106	129	139
HC25P	25	3.10	4.93	8.10	12.0	15.7	22.7	40.3	48.4	53.3	60.2	71.8	107	126	153	166
HC29P	29	3.60	5.71	9.40	13.9	18.2	26.4	46.7	56.2	61.8	69.9	83.3	124	146	178	192
HC34P	34	4.22	6.70	11.0	16.3	21.4	30.9	54.8	65.9	72.5	81.9	97.7	145	171	209	225
HC40P	40	4.96	7.88	13.0	19.2	25.2	36.4	65.3	80.2	87.9	99.5	118	175	200	247	265
HC50P	50	6.20	9.85	16.2	24.0	31.4	45.5	81.6	100	110	124	147	219	250	309	331
HC60P	60	7.44	11.8	19.4	28.7	37.7	54.6	97.9	120	132	149	177	263	300	370	397
HC70P	70	8.68	13.8	22.7	33.5	44.0	63.7	114	140	154	174	206	307	350	432	464
HC80P	80	9.92	15.8	25.9	38.3	50.3	72.8	131	160	176	199	236	351	400	494	530
HC90P	90	11.2	17.7	29.2	43.1	56.6	81.9	147	180	198	224	265	395	450	556	596
HC100P	100	12.4	19.7	32.4	47.9	62.9	91.0	163	200	220	249	295	439	500	617	662
HC110P	110	13.6	21.7	35.6	52.7	69.2	100	179	220	242	274	324	482	550	679	728
HC120P	120	14.9	23.6	38.9	57.5	75.5	109	196	240	264	299	354	526	600	741	795
HC130P	130	16.1	25.6	42.1	62.3	81.6	118	211	256	277	311	362	516	582	702	732
HC145P	145	18.0	28.6	47.0	69.5	91.1	132	235	285	309	347	403	575	649	783	816
HC155P	155	19.2	30.5	50.2	74.2	97.3	141	251	305	330	371	431	615	694	837	873
HC185P	185	22.9	36.4	59.9	88.6	116	168	300	364	394	442	515	734	828	999	1042
HC210P	210	26.0	41.4	68.0	101	132	191	340	413	447	502	584	833	940	1134	1182
HB230P	230	28.5	45.3	74.5	110	144	209	373	453	490	550	640	913	1030	1243	1295
HB255P	255	31.6	50.2	82.6	122	160	232	413	502	543	610	710	1012	1142	1378	1436
HB280P	280	34.7	55.2	90.7	134	176	255	453	551	597	670	779	1111	1254	1513	1577
HB305P	305	37.8	60.1	98.8	146	192	278	494	600	650	729	849	1210	1366	1648	1717
HB345P	345	42.8	68.0	112	165	217	314	559	679	735	825	960	1369	1545	1864	1943
HB385P	385	47.7	75.8	125	184	242	350	624	757	820	921	1071	1527	1724	2080	2168
HB420P	420	52.1	82.7	136	201	264	382	680	826	895	1004	1169	1666	1881	2269	2365
HB460P	460	57.0	90.6	149	220	289	419	745	905	980	1100	1280	1825	2060	2485	2590
HB510P	510	63.2	100	165	244	320	464	826	1003	1087	1220	1419	2023	2284	2755	2872
HB560P	560	69.4	110	181	268	352	510	907	1102	1193	1339	1558	2222	2508	3025	3153
HB615P	615	76.3	121	199	295	386	560	996	1210	1310	1471	1711	2440	2754	3322	3463
HB640P	640	79.4	126	207	307	402	582	1037	1259	1363	1530	1781	2539	2866	3457	3603
HB705P	705	87.4	139	228	338	443	642	1142	1387	1502	1686	1962	2797	3157	3809	3969
HB765P	765	94.9	151	248	366	480	696	1239	1505	1630	1829	2129	3035	3426	4133	4307
HB865P	865	107	170	280	414	543	787	1401	1702	1843	2068	2407	3432	3874	4673	4870
HB920P	920	114	181	298	441	578	837	1490	1810	1960	2200	2560	3650	4120	4970	5180

H Range

Cell performance

Available amperes at +20°C ± 5°C (+68°F ± 9°F)
Performance after prolonged float charge of fully charged cells

Final voltage: 1.10 V/cell

Cell type	C ₅ Ah	HOURS				MINUTES								SECONDS		
		8 h	5 h	3 h	2 h	90 min	60 min	30 min	20 min	15 min	10 min	5 min	1 min	30 s	5 s	1 s
HC9P	9	1.09	1.73	2.83	4.17	5.44	7.66	11.7	13.5	15.0	16.8	20.2	30.6	35.6	45.0	47.4
HC12P	12	1.45	2.30	3.78	5.56	7.26	10.2	15.6	18.0	20.0	22.3	26.9	40.8	47.4	60.0	63.2
HC17P	17	2.06	3.26	5.35	7.87	10.3	14.5	22.0	25.4	28.3	31.7	38.1	57.8	67.2	85.0	89.5
HC21P	21	2.54	4.03	6.61	9.72	12.7	17.9	27.2	31.4	35.0	39.1	47.1	71.4	83.0	105	111
HC25P	25	3.03	4.80	7.87	11.6	15.1	21.3	32.4	37.4	41.7	46.6	56.1	85.0	98.8	125	132
HC29P	29	3.51	5.57	9.13	13.4	17.5	24.7	37.6	43.4	48.3	54.0	65.0	98.6	115	145	153
HC34P	34	4.11	6.53	10.7	15.7	20.6	28.9	44.1	50.9	56.7	63.3	76.2	116	134	170	179
HC40P	40	4.84	7.68	12.6	18.5	24.2	34.5	53.3	61.6	68.7	76.5	91.5	138	160	196	220
HC50P	50	6.05	9.60	15.8	23.2	30.3	43.1	66.7	77.0	85.9	95.6	114	173	200	245	275
HC60P	60	7.26	11.5	18.9	27.8	36.4	51.7	80.0	92.4	103	115	137	208	240	294	330
HC70P	70	8.47	13.4	22.1	32.4	42.4	60.3	93.3	108	120	134	160	242	280	343	385
HC80P	80	9.68	15.4	25.2	37.0	48.5	68.9	107	123	137	153	183	277	320	392	440
HC90P	90	10.9	17.3	28.4	41.7	54.5	77.5	120	139	155	172	206	311	360	441	495
HC100P	100	12.1	19.2	31.5	46.3	60.6	86.1	133	154	172	191	229	346	400	490	549
HC110P	110	13.3	21.1	34.7	50.9	66.7	94.7	147	169	189	210	252	381	440	539	604
HC120P	120	14.5	23.0	37.8	55.6	72.7	103	160	185	206	229	275	415	480	588	659
HC130P	130	15.7	25.0	41.0	60.2	78.7	112	171	194	215	237	278	411	468	557	585
HC145P	145	17.5	27.8	45.7	67.1	87.7	125	191	216	240	265	310	459	522	621	653
HC155P	155	18.8	29.8	48.8	71.8	93.8	134	204	231	256	283	332	490	558	664	698
HC185P	185	22.4	35.5	58.3	85.7	112	159	243	275	306	338	396	585	666	792	833
HC210P	210	25.4	40.3	66.2	97.2	127	181	276	313	347	383	450	664	756	899	945
HB230P	230	27.8	44.2	72.5	106	139	198	303	343	380	420	493	728	828	985	1035
HB255P	255	30.9	49.0	80.3	118	154	220	335	380	421	466	546	807	917	1092	1148
HB280P	280	33.9	53.8	88.2	130	169	241	368	417	463	511	600	886	1007	1199	1260
HB305P	305	36.9	58.6	96.1	141	185	263	401	454	504	557	653	965	1097	1306	1373
HB345P	345	41.7	66.2	109	160	209	297	454	514	570	630	739	1091	1241	1478	1553
HB385P	385	46.6	73.9	121	178	233	332	506	573	636	703	824	1218	1385	1649	1733
HB420P	420	50.8	80.6	132	194	254	362	552	625	694	767	899	1328	1511	1799	1890
HB460P	460	55.7	88.3	145	213	278	396	605	685	760	840	985	1455	1655	1970	2070
HB510P	510	61.7	97.9	161	236	309	439	671	759	843	931	1092	1613	1835	2184	2295
HB560P	560	67.8	108	176	259	339	482	737	834	925	1023	1199	1771	2015	2398	2520
HB615P	615	74.4	118	194	285	372	530	809	916	1016	1123	1317	1945	2213	2634	2768
HB640P	640	77.4	123	202	296	387	551	842	953	1057	1169	1370	2024	2303	2741	2880
HB705P	705	85.3	135	222	326	427	607	927	1050	1165	1287	1510	2230	2536	3019	3173
HB765P	765	92.6	147	241	354	463	659	1006	1139	1264	1397	1638	2420	2752	3276	3443
HB865P	865	105	166	272	400	523	745	1138	1288	1429	1580	1852	2736	3112	3704	3893
HB920P	920	111	177	290	426	557	792	1210	1370	1520	1680	1970	2910	3310	3940	4140

Cell performance

H Range

Available amperes at +20°C ± 5°C (+68°F ± 9°F)
Performance after prolonged float charge of fully charged cells

Final voltage: 1.14 V/cell

Cell type	C ₅ Ah	HOURS				MINUTES								SECONDS		
		8 h	5 h	3 h	2 h	90 min	60 min	30 min	20 min	15 min	10 min	5 min	1 min	30 s	5 s	1 s
HC9P	9	1.05	1.67	2.72	3.97	5.14	6.77	9.03	10.5	11.6	12.9	15.8	24.6	28.7	34.9	41.9
HC12P	12	1.40	2.22	3.62	5.29	6.86	9.02	12.0	14.0	15.4	17.2	21.1	32.8	38.2	46.5	55.8
HC17P	17	1.99	3.15	5.13	7.50	9.71	12.8	17.1	19.8	21.9	24.4	29.9	46.4	54.1	65.9	79.1
HC21P	21	2.46	3.89	6.34	9.26	12.0	15.8	21.1	24.5	27.0	30.1	36.9	57.4	66.9	81.4	97.7
HC25P	25	2.93	4.63	7.55	11.0	14.3	18.8	25.1	29.2	32.2	35.8	43.9	68.3	79.6	96.9	116
HC29P	29	3.39	5.37	8.76	12.8	16.6	21.8	29.1	33.8	37.3	41.5	51.0	79.2	92.4	112	135
HC34P	34	3.98	6.29	10.3	15.0	19.4	25.6	34.1	39.7	43.8	48.7	59.8	92.9	108	132	158
HC40P	40	4.68	7.40	12.1	17.7	22.9	30.5	41.2	48.0	52.8	58.5	71.4	111	128	160	168
HC50P	50	5.85	9.25	15.2	22.2	28.7	38.1	51.4	60.0	66.0	73.1	89.3	139	160	200	210
HC60P	60	7.02	11.1	18.2	26.6	34.4	45.7	61.7	71.9	79.2	87.7	107	166	192	240	252
HC70P	70	8.19	13.0	21.2	31.0	40.1	53.3	72.0	83.9	92.3	102	125	194	224	280	294
HC80P	80	9.36	14.8	24.2	35.4	45.8	60.9	82.3	95.9	106	117	143	222	256	320	336
HC90P	90	10.5	16.7	27.3	39.9	51.6	68.5	92.6	108	119	132	161	249	288	360	378
HC100P	100	11.7	18.5	30.3	44.3	57.3	76.2	103	120	132	146	179	277	321	400	420
HC110P	110	12.9	20.4	33.3	48.7	63.0	83.8	113	132	145	161	196	305	353	440	462
HC120P	120	14.0	22.2	36.4	53.2	68.8	91.4	123	144	158	175	214	332	385	480	504
HC130P	130	15.2	24.1	39.3	57.5	74.4	97.8	131	151	165	181	220	328	376	442	458
HC145P	145	17.0	26.8	43.8	64.1	82.9	109	146	169	184	202	246	366	419	493	511
HC155P	155	18.1	28.7	46.8	68.5	88.7	117	156	180	197	216	263	391	448	527	546
HC185P	185	21.6	34.2	55.9	81.8	106	139	186	215	235	257	314	467	535	629	652
HC210P	210	24.6	38.9	63.4	92.8	120	158	211	244	267	292	356	530	607	714	740
HB230P	230	26.9	42.6	69.5	102	132	173	232	268	293	320	390	580	665	783	810
HB255P	255	29.8	47.2	77.0	113	146	192	257	297	324	355	432	643	737	868	898
HB280P	280	32.8	51.8	84.6	124	160	211	282	326	356	390	475	706	810	953	986
HB305P	305	35.7	56.4	92.1	135	174	229	307	355	388	424	517	769	882	1038	1074
HB345P	345	40.4	63.8	104	152	197	259	347	401	439	480	585	870	998	1174	1215
HB385P	385	45.0	71.2	116	170	220	290	388	448	490	536	653	971	1113	1310	1356
HB420P	420	49.1	77.7	127	186	240	316	423	488	534	584	712	1059	1214	1429	1479
HB460P	460	53.8	85.1	139	203	263	346	463	535	585	640	780	1160	1330	1565	1620
HB510P	510	59.7	94.4	154	225	292	384	514	593	649	710	865	1286	1475	1735	1796
HB560P	560	65.5	104	169	248	320	421	564	651	712	779	950	1412	1619	1905	1972
HB615P	615	72.0	114	186	272	352	462	619	715	782	856	1043	1551	1778	2092	2166
HB640P	640	74.9	118	193	283	366	481	645	744	814	890	1085	1614	1850	2177	2254
HB705P	705	82.5	130	213	312	403	530	710	820	897	981	1195	1778	2038	2399	2483
HB765P	765	89.5	142	231	338	438	575	770	890	973	1064	1297	1929	2212	2603	2694
HB865P	865	101	160	261	382	495	650	871	1006	1100	1203	1467	2181	2501	2943	3046
HB920P	920	108	170	278	407	526	692	927	1070	1170	1280	1560	2320	2660	3130	3240

H Range

Cell performance for engine starting applications

Available amperes at +20°C ± 5°C (+68°F ± 9°F)

Performance for fully charged cells by a constant current charge according to IEC 60623 standard.

Final voltage: 0.65 V/cell

Cell type	C ₅ Ah	SECONDS					
		90 s	60 s	30 s	15 s	5 s	1 s
HC9P	9	85.7	96.1	111	129	144	162
HC12P	12	114	128	147	172	191	216
HC17P	17	162	181	209	244	271	306
HC21P	21	200	224	258	301	335	378
HC25P	25	238	267	307	359	399	450
HC29P	29	276	309	356	416	463	522
HC34P	34	324	363	418	488	542	612
HC40P	40	393	439	502	580	646	719
HC50P	50	491	548	627	725	808	899
HC60P	60	589	658	753	870	969	1080
HC70P	70	687	768	878	1010	1130	1260
HC80P	80	785	877	1000	1160	1290	1440
HC90P	90	883	987	1130	1300	1450	1620
HC100P	100	981	1100	1260	1450	1620	1800
HC110P	110	1080	1210	1380	1590	1780	1980
HC120P	120	1180	1320	1510	1740	1940	2160
HC130P	130	1210	1340	1500	1720	1880	2040
HC145P	145	1350	1490	1680	1920	2100	2280
HC155P	155	1440	1600	1790	2050	2250	2430
HC185P	185	1720	1910	2140	2440	2680	2900
HC210P	210	1950	2160	2430	2770	3040	3300
HB230P	230	2140	2370	2660	3040	3330	3610
HB255P	255	2370	2630	2950	3370	3700	4000
HB280P	280	2600	2880	3240	3700	4060	4400
HB305P	305	2840	3140	3530	4030	4420	4790
HB345P	345	3210	3550	3990	4560	5000	5420
HB385P	385	3580	3970	4450	5090	5580	6040
HB420P	420	3910	4330	4860	5550	6090	6590
HB460P	460	4280	4740	5320	6080	6670	7220
HB510P	510	4740	5250	5900	6740	7390	8010
HB560P	560	5210	5770	6470	7400	8120	8790
HB615P	615	5720	6330	7110	8120	8910	9660
HB640P	640	5950	6590	7400	8450	9280	10050
HB705P	705	6560	7260	8150	9310	10220	11070
HB765P	765	7120	7880	8840	10110	11090	12010
HB865P	865	8050	8910	10000	11430	12540	13580
HB920P	920	8560	9480	10640	12150	13330	14440

Final voltage: 0.85 V/cell

Cell type	C ₅ Ah	SECONDS					
		90 s	60 s	30 s	15 s	5 s	1 s
HC9P	9	66.5	74.0	84.1	98.7	110	121
HC12P	12	88.7	98.6	112	132	146	161
HC17P	17	126	140	159	186	207	228
HC21P	21	155	173	196	230	256	282
HC25P	25	185	205	234	274	305	335
HC29P	29	214	238	271	318	354	389
HC34P	34	251	279	318	373	415	456
HC40P	40	303	336	382	443	492	537
HC50P	50	379	419	477	554	615	671
HC60P	60	455	503	573	665	738	805
HC70P	70	531	587	668	776	861	940
HC80P	80	607	671	763	887	984	1070
HC90P	90	682	755	859	998	1110	1210
HC100P	100	758	839	954	1110	1230	1340
HC110P	110	834	923	1050	1220	1350	1480
HC120P	120	910	1010	1150	1330	1480	1610
HC130P	130	922	1010	1130	1280	1390	1510
HC145P	145	1030	1130	1260	1430	1550	1690
HC155P	155	1100	1200	1340	1530	1660	1800
HC185P	185	1310	1440	1610	1820	1980	2150
HC210P	210	1490	1630	1820	2070	2250	2440
HB230P	230	1630	1790	2000	2260	2460	2670
HB255P	255	1810	1980	2210	2510	2730	2970
HB280P	280	1990	2170	2430	2760	3000	3260
HB305P	305	2160	2370	2650	3000	3260	3550
HB345P	345	2450	2680	2990	3400	3690	4010
HB385P	385	2730	2990	3340	3790	4120	4480
HB420P	420	2980	3260	3640	4130	4490	4880
HB460P	460	3260	3570	3990	4530	4920	5350
HB510P	510	3620	3960	4420	5020	5460	5930
HB560P	560	3970	4350	4860	5510	5990	6510
HB615P	615	4360	4780	5330	6050	6580	7150
HB640P	640	4540	4970	5550	6300	6850	7440
HB705P	705	5000	5470	6110	6940	7540	8200
HB765P	765	5430	5940	6640	7530	8180	8900
HB865P	865	6140	6720	7500	8510	9250	10060
HB920P	920	6530	7140	7980	9060	9840	10700

Standard layouts

Alcad has developed a series of standard layouts by which a battery may be ordered. Whether the battery is being installed on a rack, in a cabinet or is simply free-standing, the same configuration principles can be applied. There are two ways to configure the battery. The first is the normal method and is used on all LCE..P, MC..P and HC..P cell types. The cell's length is used to calculate the row length, shown in figure 1. The second method is shown in figure 2. It is used on the majority of Alcad's LBE..P, MB..P and HB..P cells, where the cell is turned through 90° and then connected width-to-width. This is referred to as 'crosswise' mounted and its purpose is to minimise the installation's overall length.

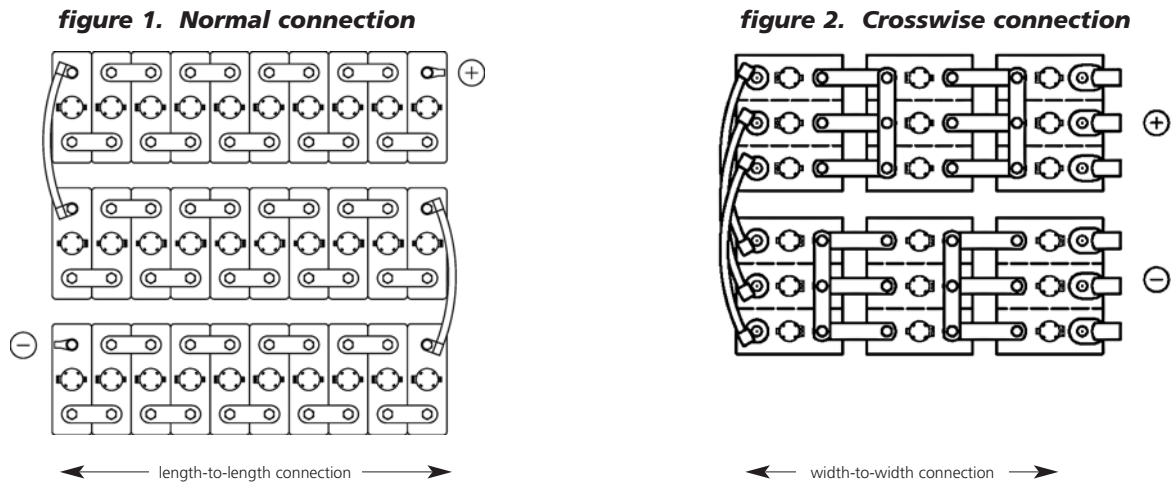

Table 1 demonstrates the connection method for Alcad's extended range of cells. All other designations utilise the normal method of connection (length-to-length).

Table 1

Connection type	LBE..P	MB..P	HB..P
Normal	LBE415P to LBE510P	MB370P to MB390P	-
Crosswise	LBE550P to LBE1660P	MB415P to MB1390P	HB230P to HB920P

Battery layout

Assembly method

Whatever your installation, use these simple guidelines when calculating your preferred configuration.

1. From the data in this publication, define the total number of cells in the battery.
2. Divide the length of the available installation area by the cell length (normal mount) or width (crosswise mount). This gives the maximum number of cells per row.
3. Divide the width (depth) of the available area by the cell width (normal mount) or length (crosswise mount). This will give the maximum number of rows.

For example

If we consider a cabinet with three shelves : each shelf has a length of 440 mm and a width 380 mm. The battery comprises of ninety cells type LCE30P, (figure 3).

figure 3.

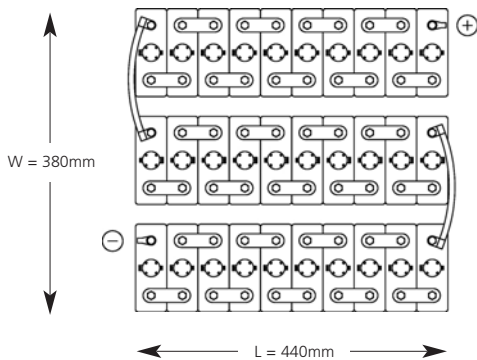

The LCE30P has length of 42 mm and width 121 mm.

$$\frac{440}{42} = 10 \text{ cells per row}$$

$$\frac{380}{121} = 3 \text{ rows per shelf}$$

A total of 30 cells can therefore be fitted on each shelf.

Whilst this is an ideal example, the calculation formula can be applied to all rack, cabinet and free-standing installations. For engineering assistance on complex layouts, please contact the company or its agent.

When ordering a battery rack, please specify the battery type and the preferred rack configuration (see pages 23-25). If your battery is being assembled in a cabinet, or is free-standing, please specify the number of rows, cells per row and total number of cells. This will ensure that all necessary inter-row and inter-tier flexible connectors are provided.

Battery racks

Alcad's product portfolio includes standard and anti-seismic battery racks (conforming to Uniform Building Code, Seismic Zone 4). These have been designed for all cell types in the Alcad range and are supplied unassembled to allow for easy installation. The purpose-built racks are strong, adaptable and provide good alkali protection.

Dimensions are given below for the range of rack layouts. Rack lengths are available in increments of 150 mm from 600 mm to a maximum of 6,000 mm. Calculate the required length using the cell length on page 5, 10, or 15 for normal connection, and by using the cell width 195 mm for crosswise connection.

1. Dimensions (mm) for single tier, standard floor mounted racks : single cell range

Cell type			1 tier rack					
LCE..P	MC..P	HC..P	Depth (D) No. of steps			Height (H) No. of steps		
			2	3	4	2	3	4
10 to 62	9 to 55	9 to 34	430	645	860	560	660	760
75 to 220	70 to 185	40 to 120	430	645	860	643	743	843
235 to 375	215 to 335	130 to 210	430	645	860	699	799	899

2. Dimensions (mm) for double tier, standard floor mounted racks : single cell range

Cell type			2 tier rack					
LCE..P	MC..P	HC..P	Depth (D) No. of steps			Height (H) No. of steps		
			2	3	4	2	3	4
10 to 62	9 to 55	9 to 34	500	715	930	1565	1665	1765
75 to 220	70 to 185	40 to 120	500	715	930	1648	1748	1848
235 to 375	215 to 335	130 to 210	500	715	930	1704	1804	1904

3. Dimensions (mm) for single tier, standard floor mounted racks : extended cell range

Cell type			1 tier rack							
LBE..P	MB..P	HB..P	1	Depth (D) No. of steps			Height (H) No. of steps			
				2	3	4	1	2	3	4
415 to 510*	370 to 390*	-	-	430	645	860	-	690	790	890
550	415 to 460	230 to 305	-	430	645	860	-	690	790	890
600 to 830	505 to 690	345 to 460	-	580	870	-	-	690	790	-
925 to 1300	740 to 965	510 to 640	-	860	-	-	-	690	-	-
1400 to 1660	1040 to 1390	705 to 920	580	1160	-	-	590	690	-	-

* normal connection

4. Dimensions (mm) for double tier, standard floor mounted racks : extended cell range

Cell type			2 tier rack							
LBE..P	MB..P	HB..P	1	Depth (D) No. of steps			Height (H) No. of steps			
				2	3	4	1	2	3	4
415 to 510*	370 to 390*	-	-	500	715	930	-	1695	1795	1895
550	415 to 460	230 to 305	-	500	715	930	-	1695	1795	1895
600 to 830	505 to 690	345 to 460	-	650	940	-	-	1695	1795	-
925 to 1300	740 to 965	510 to 640	-	930	-	-	-	1695	-	-
1400 to 1660	1040 to 1390	705 to 920	650	1230	-	-	1595	1695	-	-

* normal connection

Battery racks

5. Designations for single and double tier, standard floor mounted racks : single cell range (diagrams 1 to 6)

Cell type			1 tier No. of steps			2 tier No. of steps		
LCE..P	MC..P	HC..P	2	3	4	2	3	4
10 to 62	9 to 55	9 to 34	SGL2	SGL3	SGL4	ESGL2	ESGL3	ESGL4
75 to 220	70 to 185	40 to 120	SGL2	SGL3	SGL4	ESGL2	ESGL3	ESGL4
235 to 375	215 to 335	130 to 210	SGL2	SGL3	SGL4	ESGL2	ESGL3	ESGL4

6. Designations for single and double tier, standard floor mounted racks : extended cell range (diagrams 7 - 10)

Cell type			1 tier No. of steps				2 tier No. of steps			
LBE..P	MB..P	HB..P	1	2	3	4	1	2	3	4
415 to 510*	370 to 390*	-	-	SGL2	SGL3	SGL4	-	ESGL2	ESGL3	ESGL4
550	415 to 460	230 to 305	-	SGL2	SGL3	SGL4	-	ESGL2	ESGL3	ESGL4
600 to 830	505 to 690	345 to 460	-	SGS2	SGS3	-	-	ESGS2	ESGS3	-
925 to 1300	740 to 965	510 to 640	-	SGT2	-	-	-	ESGT2	-	-
1400 to 1660	1040 to 1390	705 to 920	PGS2	SGU2	-	-	EPGS2	ESGU2	-	-

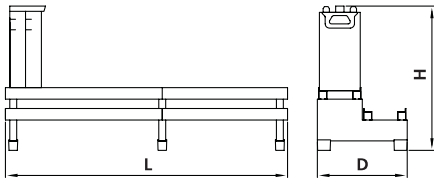

Diagram 1.
1 tier, 2 steps, normal connection

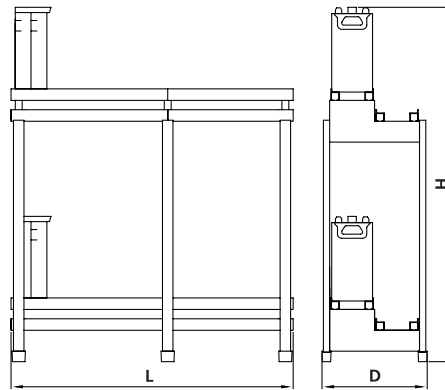

Diagram 2.
2 tier, 2 steps, normal connection

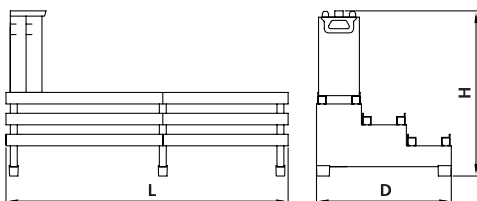

Diagram 3.
1 tier, 3 steps, normal connection

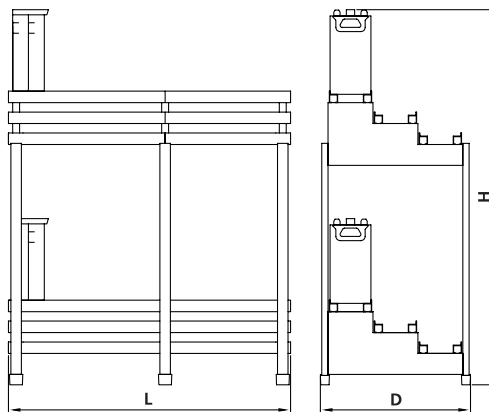

Diagram 4.
2 tier, 3 steps, normal connection

Battery racks

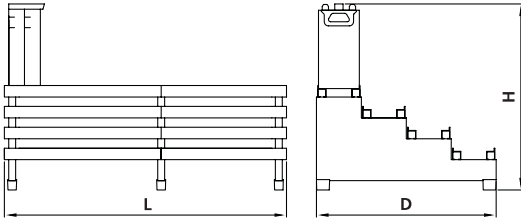

Diagram 5.
1 tier, 4 steps, normal connection

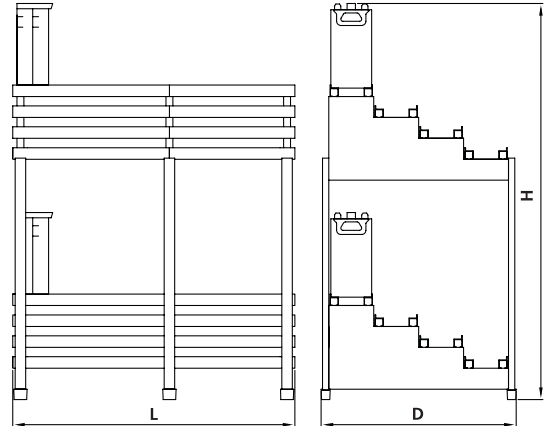

Diagram 6.
2 tier, 4 steps, normal connection

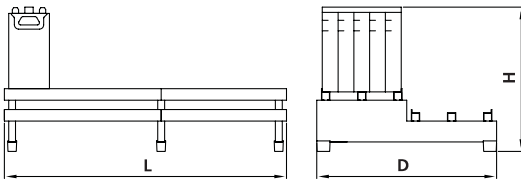

Diagram 7.
1 tier, 2 steps, crosswise connection

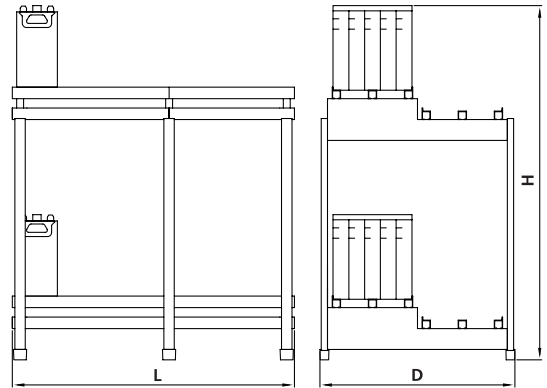

Diagram 8.
2 tier, 2 steps, crosswise connection

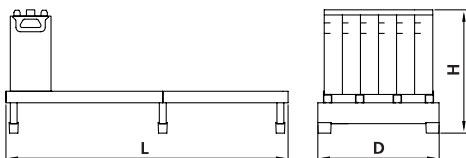

Diagram 9.
1 tier, 1 step, crosswise connection

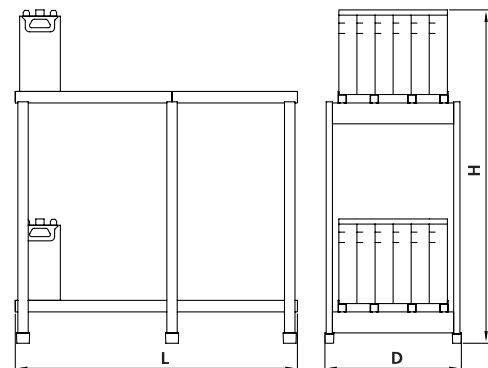

Diagram 10.
2 tier, 1 step, crosswise connection

Disposal and recycling

In a world where autonomous sources of electric power are ever more in demand, Alcad batteries provide an environmentally responsible answer to these needs. Environmental management lies at the core of Alcad's business and we take care to control every stage of a battery's life-cycle in terms of potential impact. Environmental protection is our top priority, from design and production through end-of-life collection, disposal and recycling.

Our respect for the environment is complemented by an equal respect for our customers. We aim to generate confidence in our products, not only from a functional standpoint, but also in terms of the environmental safeguards that are built into their life-cycle. The simple and unique nature of the battery components make them readily recyclable and this process safeguards valuable natural resources for future generations.

In partnership with collection agencies worldwide, Alcad organises retrieval from pre-collection points and the recycling of spent Alcad batteries. Information about Alcad's collection network can be found on our web site :

www.alcad.com

Ni-Cd batteries must not be discarded as harmless waste and should be treated carefully in accordance with local and national regulations. Your Alcad representative can assist with further information on these regulations and with the overall recycling procedure.

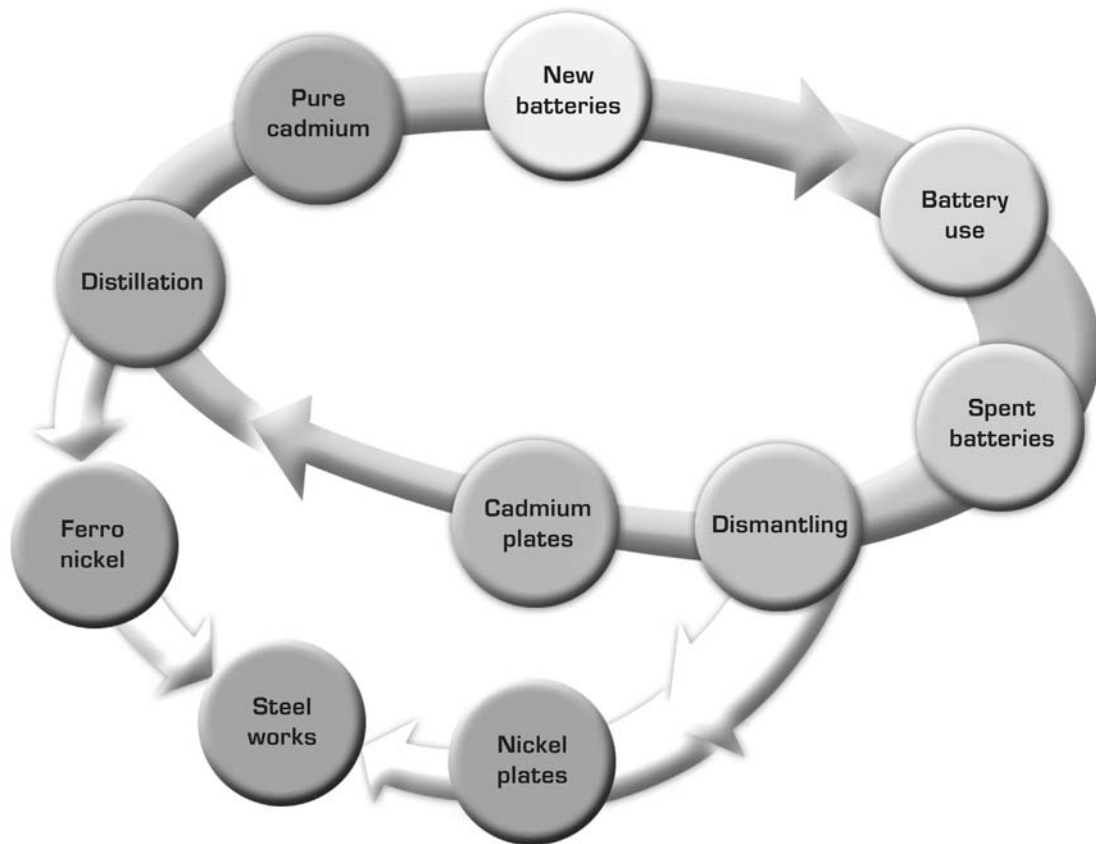



Single Cell Range

including LCE P – LBE P

Delivering quality

ALCAD

ALCAD Single Cell Range

Alcad have nearly 100 years' experience in the development and manufacture of pocket plate cells and batteries.

Today, they offer the widest range of high quality nickel-cadmium batteries available throughout the world and this publication details the Single Cell ranges of pocket plate products.

Alcad nickel-cadmium batteries are the battery of choice for many applications. Their outstanding features are :

- operation over a temperature range between -20°C to $+50^{\circ}\text{C}$ (-4°F to $+122^{\circ}\text{F}$), with extremes of -50°C to $+70^{\circ}\text{C}$ (-58°F to $+158^{\circ}\text{F}$) for short periods
- life in excess of 25 years in many applications
- good performance at low temperatures
- resistance to high temperature ageing
- resistance to electrical abuse
- resistance to shock and vibration
- simple maintenance
- low installation cost
- low life-cycle cost

The major design features of the Alcad Single Cell ranges are :

- fully welded internal construction of steel components
- strong welded polypropylene containers as standard
- flame retardant welded containers, as option
- flip-top flame arresting vents as standard

Alcad supports these Single Cell ranges with :

- quality approved manufacture to ISO 9001
- Single Cell batteries have been developed in line with the safety requirements of EN-50272-2 and components used (such as insulated cable connectors and end lug covers) are defined to ensure high protection against electric shocks (IP2 level).
- full recycling service to protect the environment

The Alcad Single Cell ranges meet, and exceed, the requirements of the IEC 60623 standard.

The Single Cell portfolio comprises three ranges of high, medium and low rate discharge types.

L type

The L type range has the thickest plates and is designed for applications where the battery is required to provide a reliable source of energy over relatively long discharge periods.

Normally, the current is relatively low in comparison with the total stored energy and the discharges are generally infrequent. Typical uses are power back-up and bulk energy storage.

M type

The M type range is designed for applications where the batteries are usually required to sustain electrical loads for between 30 minutes to 3 hours or for « mixed » loads which involve a mixture of high and low discharge rates.

The applications can have frequent or infrequent discharges. The range is typically used in power back-up applications.

H type

The H type range uses very thin plates and is designed for applications where there is a demand for a relatively high current over short periods, usually less than 30 minutes in duration.

The applications can have frequent or infrequent discharges. The range is typically used in starting and power back-up applications.





Contents

Construction features 4

LE range

- Cell dimensions and internal resistance 5
- Cell performance data 6

M range

- Cell dimensions and internal resistance 10
- Cell performance data 11

H range

- Cell dimensions and internal resistance 15
- Cell performance data 16

Battery layout 21

Battery racks 23

Disposal and recycling 26

Float-corrected data

Many nickel-cadmium batteries are used in stationary standby power applications where discharges occur infrequently and the battery is continuously charged by a float or constant potential charge. Under these circumstances there is a modification in the level of the discharge curve and allowances must be made for this when sizing the battery.

In order to simplify this process, the data Alcad supplies in this publication already takes into account this phenomenon. The data published by Alcad is the performance after prolonged floating and it can be used directly in battery sizing calculations.

This phenomenon occurs with all nickel-cadmium batteries, but some other manufacturers of nickel-cadmium batteries may not take this effect into account in published data.

When calculating for deep discharges (0.65 V and 0.85 V) it is not necessary to take this effect into account.

Single Cell Construction features

Connector cover
In line with EN 50272-2 (safety) with IP2 level.

Plate group bus
Connects the plate tabs with the terminal post. Plate tabs and terminal posts are projection welded to the plate group bus.

Plate
Horizontal pockets of double-perforated steel strips.

Flame-arresting vent

Terminal seal
This is mechanically clipped and provides an excellent seal. This minimises carbonation deposits.

Plate tab
Spot welded to the plate side frames, to the upper edge of the pocket plate and to the plate group bus.

Separating grids
These separate the plates and insulate the plate frames from each other. The grids allow free circulation of electrolyte between the plates.

Plate frame
Seals the plate pockets and serves as a current collector.



The Alcad Single Cell ranges fully comply and exceed the IEC 60623 standard requirements.

Cell dimensions and internal resistance

LE Range

LE cells are normally supplied as single cells, taped together into blocks or assembled in steel crates.

Cell type	Capacity at the 5h rate (Ah)	Volume of liquid electrolyte above plates (cc)	Approx. weight per cell		Overall height		Width per cell		Length per cell		Internal resistance* (mOhm)	Electrolyte height between Min - Max (mm)
			(kg)	(lb)	(mm)	(ins)	(mm)	(ins)	(mm)	(ins)		
LCE10P	10	146	1.6	3.6	275	10.83	121	4.76	42	1.65	14.4	35
LCE15P	15	146	1.7	3.7	275	10.83	121	4.76	42	1.65	9.60	35
LCE22P	22	143	1.9	4.1	275	10.83	121	4.76	42	1.65	6.55	35
LCE30P	30	143	2.0	4.3	275	10.83	121	4.76	42	1.65	4.80	35
LCE40P	40	235	3.1	6.8	275	10.83	121	4.76	66	2.60	3.60	35
LCE47P	47	238	3.0	6.6	275	10.83	121	4.76	66	2.60	3.06	35
LCE62P	62	235	3.3	7.3	275	10.83	121	4.76	66	2.60	2.32	35
LCE75P	75	559	6.0	13.1	358	14.09	192	7.56	68	2.68	2.33	50
LCE90P	90	552	6.6	14.6	358	14.09	192	7.56	68	2.68	1.94	50
LCE110P	110	552	6.6	14.6	358	14.09	192	7.56	68	2.68	1.59	50
LCE145P	145	546	7.2	15.9	358	14.09	192	7.56	68	2.68	1.21	50
LCE185P	185	771	9.6	21.1	358	14.09	192	7.56	93	3.66	0.95	50
LCE220P	220	765	10.2	22.5	358	14.09	192	7.56	93	3.66	0.80	50
LCE235P	235	771	12.1	26.7	414	16.30	192	7.56	93	3.66	0.77	50
LCE280P	280	765	12.8	28.3	414	16.30	192	7.56	93	3.66	0.65	50
LCE330P	330	1020	16.6	36.5	414	16.30	192	7.56	122	4.80	0.55	50
LCE375P	375	1015	17.2	37.8	414	16.30	192	7.56	122	4.80	0.48	50
LBE415P	415	1090	18.3	40.3	405	15.94	195	7.68	146	5.75	0.44	50
LBE460P	460	1180	19.8	43.7	405	15.94	195	7.68	159	6.26	0.39	50
LBE510P	510	1290	21.4	47.2	405	15.94	195	7.68	171	6.73	0.35	50
LBE550P	550	1400	23.0	50.7	405	15.94	195	7.68	183	7.20	0.33	50
LBE600P	600	1590	26.7	58.9	405	15.94	195	7.68	206	8.11	0.30	50
LBE650P	650	1680	28.2	62.2	405	15.94	195	7.68	219	8.62	0.28	50
LBE700P	700	1770	29.7	65.5	405	15.94	195	7.68	232	9.13	0.26	50
LBE750P	750	1880	31.3	69.0	405	15.94	195	7.68	244	9.61	0.24	50
LBE830P	830	2100	34.5	76.1	405	15.94	195	7.68	268	10.55	0.22	50
LBE925P	925	2360	39.6	87.3	405	15.94	195	7.68	304	11.97	0.20	50
LBE1020P	1020	2580	42.8	94.4	405	15.94	195	7.68	328	12.91	0.18	50
LBE1100P	1100	2800	46.0	101.4	405	15.94	195	7.68	352	13.86	0.16	50
LBE1200P	1200	3060	51.1	112.7	405	15.94	195	7.68	389	15.31	0.15	50
LBE1300P	1300	3300	54.3	119.7	405	15.94	195	7.68	413	16.26	0.14	50
LBE1400P	1400	3500	57.5	126.8	405	15.94	195	7.68	437	17.20	0.13	50
LBE1500P	1500	3900	64.2	141.5	405	15.94	195	7.68	486	19.13	0.12	50
LBE1600P	1600	4090	67.4	148.6	405	15.94	195	7.68	510	20.08	0.11	50
LBE1660P	1660	4200	69.0	152.1	405	15.94	195	7.68	522	20.55	0.11	50

*Rigid connector included

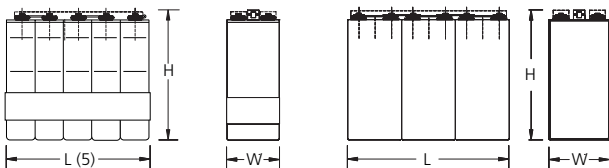

LCE10P - LCE375P
Taped block length =
cell length x no of cells + 2mm/0.1 in.

LBE415P - LBE1660P

Cell connection bolt per pole:	LBE415P to LBE550P:	2 x M10	
LCE10P to LCE62P:	M6	LBE600P to LBE830P:	3 x M10
LCE75P to LCE90P:	M8	LBE925P to LBE1100P:	4 x M10
LCE110P to LCE280P:	M10	LBE1200P to LBE1400P:	5 x M10
LCE330P to LCE375P:	2 x M10	LBE1500P to LBE1660P:	6 x M10

LE Range Cell performance

Available amperes at +20°C ± 5°C (+68°F ± 9°F)
Performance after prolonged float charge of fully charged cells

Final voltage: 1.00 V/cell

Cell type	C ₅ Ah	HOURS					MINUTES									SECONDS		
		10 h	8 h	5 h	3 h	2 h	90 min	60 min	45 min	30 min	20 min	15 min	10 min	5 min	1 min	30 s	5 s	1 s
LCE10P	10	1.03	1.28	2.00	3.20	4.23	5.10	6.46	7.50	8.96	10.1	10.9	12.0	14.4	17.9	19.8	25.5	28.7
LCE15P	15	1.54	1.91	3.00	4.80	6.35	7.65	9.69	11.3	13.4	15.1	16.3	18.0	21.6	26.8	29.7	38.3	43.1
LCE22P	22	2.26	2.81	4.40	7.04	9.31	11.23	14.2	16.5	19.7	22.2	23.9	26.4	31.7	39.3	43.6	56.1	63.2
LCE30P	30	3.08	3.83	6.00	9.60	12.7	15.3	19.4	22.5	26.9	30.3	32.6	36.0	43.2	53.6	59.4	76.6	86.2
LCE40P	40	4.10	5.10	8.00	12.8	16.9	20.4	25.8	30.0	35.9	40.3	43.5	48.0	57.6	71.4	79.3	102	115
LCE47P	47	4.82	5.99	9.40	15.0	19.9	24.0	30.4	35.3	42.1	47.4	51.1	56.4	67.7	83.9	93.1	120	135
LCE62P	62	6.36	7.91	12.4	19.8	26.2	31.6	40.1	46.5	55.6	62.5	67.5	74.4	89.3	111	123	158	178
LCE75P	75	7.58	9.47	15.0	24.0	32.1	37.8	46.5	52.9	61.6	69.3	73.2	79.2	90.0	113	121	154	171
LCE90P	90	9.09	11.4	18.0	28.8	38.5	45.4	55.8	63.5	74.0	83.1	87.8	95.0	108	135	145	185	205
LCE110P	110	11.1	13.9	22.0	35.2	47.1	55.5	68.3	77.6	90.4	102	107	116	132	166	177	226	251
LCE145P	145	14.6	18.3	29.0	46.4	62.0	73.1	90.0	102	119	134	142	153	174	218	234	298	331
LCE185P	185	18.7	23.4	37.0	59.2	79.1	93.3	115	131	152	171	181	195	222	278	299	380	422
LCE220P	220	22.2	27.8	44.0	70.4	94.1	111.0	137	155	181	203	215	232	264	331	355	452	502
LCE235P	235	24.2	30.0	47.0	75.2	98.3	115.7	142	163	189	211	226	248	271	329	353	423	455
LCE280P	280	28.8	35.7	56.0	89.6	117	138	169	194	225	252	269	296	323	392	420	504	542
LCE330P	330	34.0	42.1	66.0	106	138	163	199	229	266	297	317	348	380	461	495	594	639
LCE375P	375	38.6	47.8	75.0	120	157	185	226	260	302	337	360	396	432	524	563	675	726
LBE415P	415	42.7	52.9	83.0	133	174	204	250	288	334	373	398	438	478	580	623	747	804
LBE460P	460	47.4	58.7	92.0	147	193	227	278	319	370	414	442	486	530	643	690	829	891
LBE510P	510	52.5	65.0	102	163	213	251	308	354	411	459	490	539	588	713	766	919	988
LBE550P	550	56.7	70.1	110	176	230	271	332	382	443	495	528	581	634	769	826	991	1065
LBE600P	600	61.8	76.5	120	192	251	295	362	417	483	539	576	634	691	839	901	1081	1162
LBE650P	650	67.0	82.9	130	208	272	320	392	451	523	584	624	686	749	909	976	1171	1259
LBE700P	700	72.1	89.3	140	224	293	345	422	486	564	629	672	739	806	979	1051	1261	1355
LBE750P	750	77.3	95.6	150	240	314	369	453	521	604	674	720	792	864	1049	1126	1351	1452
LBE830P	830	85.5	106	166	266	347	409	501	576	668	746	797	876	956	1161	1246	1495	1607
LBE925P	925	95.3	118	185	296	387	456	558	642	745	832	888	977	1066	1294	1388	1666	1791
LBE1020P	1020	105	130	204	326	427	502	616	708	821	917	979	1077	1175	1426	1531	1837	1975
LBE1100P	1100	113	140	220	352	460	542	664	764	886	989	1056	1162	1267	1538	1651	1981	2130
LBE1200P	1200	124	153	240	384	502	591	724	833	966	1079	1152	1267	1382	1678	1801	2161	2324
LBE1300P	1300	134	166	260	416	544	640	785	903	1047	1169	1248	1373	1498	1818	1951	2342	2517
LBE1400P	1400	144	179	280	448	586	689	845	972	1127	1259	1344	1478	1613	1958	2101	2522	2711
LBE1500P	1500	155	191	300	480	628	739	905	1042	1208	1349	1440	1584	1728	2098	2252	2702	2904
LBE1600P	1600	165	204	320	512	670	788	966	1111	1288	1439	1536	1690	1843	2237	2402	2882	3098
LBE1660P	1660	171	212	332	531	695	817	1002	1153	1336	1493	1594	1753	1912	2321	2492	2990	3214

Cell performance **LE Range**

Available amperes at +20°C ± 5°C (+68°F ± 9°F)
Performance after prolonged float charge of fully charged cells

Final voltage: 1.05 V/cell

Cell type	C ₅ Ah	HOURS					MINUTES									SECONDS		
		10 h	8 h	5 h	3 h	2 h	90 min	60 min	45 min	30 min	20 min	15 min	10 min	5 min	1 min	30 s	5 s	1 s
LCE10P	10	1.02	1.26	1.96	3.10	3.94	4.53	5.62	6.29	7.36	8.53	9.20	10.2	10.7	14.4	16.2	21.1	23.8
LCE15P	15	1.53	1.89	2.94	4.65	5.90	6.79	8.43	9.44	11.0	12.8	13.8	15.2	16.0	21.6	24.3	31.6	35.6
LCE22P	22	2.24	2.78	4.31	6.82	8.66	9.96	12.4	13.8	16.2	18.8	20.2	22.4	23.4	31.7	35.6	46.4	52.3
LCE30P	30	3.06	3.79	5.88	9.30	11.8	13.6	16.9	18.9	22.1	25.6	27.6	30.5	32.0	43.2	48.5	63.3	71.3
LCE40P	40	4.08	5.05	7.84	12.4	15.7	18.1	22.5	25.2	29.4	34.1	36.8	40.7	42.6	57.6	64.7	84.4	95.0
LCE47P	47	4.79	5.93	9.21	14.6	18.5	21.3	26.4	29.6	34.6	40.1	43.3	47.8	50.1	67.7	76.0	99.1	112
LCE62P	62	6.32	7.83	12.2	19.2	24.4	28.1	34.8	39.0	45.6	52.9	57.1	63.0	66.1	89.4	100	131	147
LCE75P	75	7.50	9.38	14.7	23.5	29.3	33.5	39.4	44.0	50.4	56.9	60.8	65.8	73.3	90.7	100	127	140
LCE90P	90	9.00	11.3	17.6	28.2	35.2	40.2	47.2	52.8	60.5	68.3	73.0	79.0	87.9	109	120	152	168
LCE110P	110	11.0	13.8	21.6	34.5	43.0	49.2	57.7	64.5	73.9	83.4	89.2	96.6	107	133	147	186	205
LCE145P	145	14.5	18.1	28.4	45.4	56.7	64.8	76.1	85.1	97.4	110	118	127	142	175	194	245	270
LCE185P	185	18.5	23.1	36.3	58.0	72.4	82.7	97.1	109	124	140	150	162	181	224	247	312	345
LCE220P	220	22.0	27.5	43.1	68.9	86.1	98.4	115	129	148	167	178	193	215	266	294	371	410
LCE235P	235	24.0	29.8	46.5	72.9	90.9	102.4	121	135	154	170	176	195	230	264	289	347	377
LCE280P	280	28.6	35.5	55.4	86.8	108	122	145	161	184	202	210	233	274	315	344	413	449
LCE330P	330	33.7	41.9	65.3	102	128	144	170	190	216	239	247	274	322	371	406	487	529
LCE375P	375	38.3	47.6	74.3	116	145	163	194	216	246	271	281	312	366	422	461	554	601
LBE415P	415	42.3	52.7	82.2	129	161	181	214	239	272	300	311	345	405	467	511	613	665
LBE460P	460	46.9	58.4	91.1	143	178	200	238	265	302	333	344	383	449	517	566	679	737
LBE510P	510	52.0	64.7	101	158	197	222	263	294	335	369	382	424	498	574	627	753	817
LBE550P	550	56.1	69.8	109	171	213	240	284	317	361	398	412	457	537	619	677	812	882
LBE600P	600	61.2	76.1	119	186	232	261	310	346	394	434	449	499	586	675	738	886	962
LBE650P	650	66.3	82.5	129	202	251	283	336	374	426	470	487	541	635	731	800	960	1042
LBE700P	700	71.4	88.8	139	217	271	305	362	403	459	506	524	582	684	787	861	1033	1122
LBE750P	750	76.5	95.2	149	233	290	327	387	432	492	542	562	624	733	844	923	1107	1202
LBE830P	830	84.7	105	164	257	321	362	429	478	544	600	622	690	811	934	1021	1225	1330
LBE925P	925	94.4	117	183	287	358	403	478	533	607	669	693	769	904	1040	1138	1366	1483
LBE1020P	1020	104	129	202	316	394	444	527	588	669	737	764	848	996	1147	1255	1506	1635
LBE1100P	1100	112	140	218	341	425	479	568	634	722	795	824	915	1074	1237	1353	1624	1763
LBE1200P	1200	122	152	238	372	464	523	620	691	787	867	899	998	1172	1350	1476	1772	1923
LBE1300P	1300	133	165	257	403	503	566	672	749	853	940	973	1081	1270	1462	1599	1919	2084
LBE1400P	1400	143	178	277	434	541	610	723	806	918	1012	1048	1164	1368	1575	1722	2067	2244
LBE1500P	1500	153	190	297	465	580	654	775	864	984	1084	1123	1247	1465	1687	1845	2214	2404
LBE1600P	1600	163	203	317	496	619	697	827	922	1050	1157	1198	1331	1563	1800	1968	2362	2565
LBE1660P	1660	169	211	329	515	642	723	858	956	1089	1200	1243	1380	1621	1867	2042	2451	2661

LE Range Cell performance

Available amperes at +20°C ± 5°C (+68°F ± 9°F)
Performance after prolonged float charge of fully charged cells

Final voltage: 1.10 V/cell

Cell type	C _c Ah	HOURS					MINUTES									SECONDS		
		10 h	8 h	5 h	3 h	2 h	90 min	60 min	45 min	30 min	20 min	15 min	10 min	5 min	1 min	30 s	5 s	1 s
LCE10P	10	1.00	1.23	1.88	2.67	3.36	3.88	4.64	5.20	5.85	6.50	6.90	7.77	9.07	11.6	13.3	17.4	19.8
LCE15P	15	1.50	1.84	2.82	4.00	5.04	5.82	6.96	7.80	8.78	9.75	10.4	11.7	13.6	17.4	20.0	26.2	29.8
LCE22P	22	2.20	2.70	4.14	5.87	7.39	8.54	10.2	11.4	12.9	14.3	15.2	17.1	20.0	25.6	29.3	38.4	43.6
LCE30P	30	3.00	3.68	5.64	8.01	10.1	11.6	13.9	15.6	17.6	19.5	20.7	23.3	27.2	34.9	40.0	52.3	59.5
LCE40P	40	4.00	4.90	7.53	10.7	13.4	15.5	18.6	20.8	23.4	26.0	27.6	31.1	36.3	46.5	53.4	69.8	79.3
LCE47P	47	4.70	5.76	8.84	12.5	15.8	18.2	21.8	24.4	27.5	30.5	32.4	36.5	42.6	54.7	62.7	82.0	93.2
LCE62P	62	6.20	7.60	11.7	16.5	20.8	24.1	28.8	32.2	36.3	40.3	42.8	48.2	56.2	72.1	82.7	108	123
LCE75P	75	7.43	9.10	14.0	20.0	24.9	28.3	33.6	35.9	40.4	44.5	45.0	50.0	58.3	73.4	82.1	103	115
LCE90P	90	8.91	10.9	16.8	24.0	29.8	33.9	40.3	43.1	48.5	53.4	54.0	59.9	70.0	88.0	98.5	123	139
LCE110P	110	10.9	13.3	20.5	29.4	36.5	41.5	49.3	52.6	59.3	65.2	66.0	73.3	85.5	108	120	150	169
LCE145P	145	14.4	17.6	27.0	38.7	48.1	54.7	65.0	69.4	78.2	86.0	87.0	96.6	113	142	159	198	223
LCE185P	185	18.3	22.4	34.4	49.4	61.3	69.8	82.9	88.5	99.7	110	111	123	144	181	202	253	285
LCE220P	220	21.8	26.7	41.0	58.7	72.9	83.0	98.6	105	119	130	132	147	171	215	241	301	339
LCE235P	235	23.5	28.8	44.2	61.3	75.9	84.8	102	112	119	129	141	157	162	215	235	286	313
LCE280P	280	28.0	34.3	52.7	73.0	90.4	101.0	121	134	142	153	168	186	194	257	280	341	373
LCE330P	330	33.0	40.4	62.1	86.1	107	119	143	158	168	181	198	220	228	302	330	402	440
LCE375P	375	37.5	45.9	70.6	97.8	121	135	162	179	191	205	225	250	259	344	374	457	500
LBE415P	415	41.5	50.8	78.1	108	134	150	179	199	211	227	249	276	287	380	414	505	554
LBE460P	460	46.0	56.4	86.6	120	149	166	199	220	234	252	276	306	318	422	459	560	614
LBE510P	510	51.0	62.5	96.0	133	165	184	220	244	259	279	306	340	353	467	509	621	680
LBE550P	550	55.0	67.4	103	143	178	198	238	263	280	301	330	366	380	504	549	670	734
LBE600P	600	60.0	73.5	113	157	194	216	259	287	305	328	360	400	415	550	599	731	800
LBE650P	650	65.0	79.6	122	170	210	235	281	311	330	356	390	433	449	596	649	791	867
LBE700P	700	70.0	85.8	132	183	226	253	302	335	356	383	420	466	484	642	699	852	934
LBE750P	750	75.0	91.9	141	196	242	271	324	359	381	410	450	500	518	687	749	913	1000
LBE830P	830	83.0	102	156	217	268	299	359	397	422	454	498	553	574	761	829	1011	1107
LBE925P	925	92.5	113	174	241	299	334	400	443	470	506	555	616	639	848	924	1126	1234
LBE1020P	1020	102	125	192	266	329	368	441	488	518	558	612	679	705	935	1019	1242	1360
LBE1100P	1100	110	135	207	287	355	397	475	526	559	602	660	733	760	1008	1099	1339	1467
LBE1200P	1200	120	147	226	313	388	433	518	574	610	657	720	799	829	1100	1198	1461	1601
LBE1300P	1300	130	159	245	339	420	469	562	622	661	711	780	866	899	1192	1298	1583	1734
LBE1400P	1400	140	172	263	365	452	505	605	670	711	766	840	932	968	1283	1398	1705	1867
LBE1500P	1500	150	184	282	391	485	541	648	718	762	821	900	999	1037	1375	1498	1826	2001
LBE1600P	1600	160	196	301	417	517	577	691	765	813	876	960	1066	1106	1466	1598	1948	2134
LBE1660P	1660	166	203	312	433	536	599	717	794	844	908	996	1106	1147	1521	1658	2021	2214

Cell performance **LE Range**

Available amperes at +20°C ± 5°C (+68°F ± 9°F)
Performance after prolonged float charge of fully charged cells

Final voltage: 1.14 V/cell

Cell type	C ₅ Ah	HOURS					MINUTES									SECONDS			
		10 h	8 h	5 h	3 h	2 h	90 min	60 min	45 min	30 min	20 min	15 min	10 min	5 min	1 min	30 s	5 s	1 s	
LCE10P	10	0.98	1.15	1.66	2.35	2.80	3.09	3.75	4.09	4.7	5.2	5.6	5.9	6.7	9.5	11.0	14.4	16.5	
LCE15P	15	1.47	1.73	2.48	3.52	4.20	4.64	5.63	6.14	7.0	7.8	8.4	8.8	10.1	14.3	16.5	21.6	24.8	
LCE22P	22	2.16	2.53	3.64	5.17	6.16	6.80	8.25	9.01	10.3	11.4	12.3	12.9	14.8	20.9	24.2	31.7	36.3	
LCE30P	30	2.94	3.46	4.97	7.05	8.40	9.27	11.3	12.3	14.0	15.6	16.7	17.6	20.2	28.5	33.0	43.3	49.6	
LCE40P	40	3.92	4.61	6.62	9.40	11.2	12.4	15.0	16.4	18.7	20.7	22.3	23.5	26.9	38.0	44.0	57.7	66.1	
LCE47P	47	4.61	5.41	7.78	11.0	13.2	14.5	17.6	19.2	22.0	24.4	26.2	27.6	31.6	44.7	51.8	67.8	77.6	
LCE62P	62	6.08	7.14	10.3	14.6	17.4	19.2	23.3	25.4	29.0	32.1	34.5	36.5	41.7	58.9	68.3	89.4	102	
LCE75P	75	7.20	8.46	12.3	17.2	20.4	22.4	25.9	28.1	31.8	35.6	35.7	41.0	44.1	60.0	66.4	85.1	95.9	
LCE90P	90	8.64	10.2	14.7	20.6	24.5	26.9	31.1	33.7	38.1	42.8	42.8	49.1	52.9	72.0	79.6	102	115	
LCE110P	110	10.6	12.4	18.0	25.2	29.9	32.9	38.0	41.2	46.6	52.3	52.4	60.1	64.7	88.0	97.3	125	141	
LCE145P	145	13.9	16.4	23.7	33.2	39.4	43.3	50.0	54.4	61.4	68.9	69.0	79.2	85.3	116	128	164	185	
LCE185P	185	17.8	20.9	30.3	42.4	50.3	55.3	63.8	69.4	78.3	87.9	88.1	101	109	148	164	210	236	
LCE220P	220	21.1	24.8	36.0	50.4	59.8	65.8	75.9	82.5	93.1	105	105	120	129	176	195	249	281	
LCE235P	235	23.0	27.1	38.9	53.2	61.1	66.7	77.6	83.5	96.1	102	105	118	138	176	193	239	265	
LCE280P	280	27.4	32.3	46.4	63.3	72.8	79.4	92.4	99.5	114	121	125	141	165	209	229	284	316	
LCE330P	330	32.3	38.0	54.6	74.6	85.8	93.6	109	117	135	143	148	166	194	247	270	335	372	
LCE375P	375	36.8	43.2	62.1	84.8	97.5	106.4	124	133	153	162	168	189	221	280	307	381	423	
LBE415P	415	40.7	47.8	68.7	93.9	108	118	137	147	170	179	186	209	244	310	340	422	468	
LBE460P	460	45.1	53.0	76.2	104	120	131	152	163	188	199	206	232	270	344	377	467	519	
LBE510P	510	50.0	58.8	84.5	115	133	145	168	181	208	220	228	257	300	381	418	518	575	
LBE550P	550	53.9	63.4	91.1	124	143	156	182	195	225	238	246	277	323	411	451	559	620	
LBE600P	600	58.8	69.1	99.4	136	156	170	198	213	245	259	269	302	353	448	492	610	676	
LBE650P	650	63.7	74.9	108	147	169	184	215	231	266	281	291	328	382	486	533	660	733	
LBE700P	700	68.6	80.6	116	158	182	199	231	249	286	302	314	353	412	523	574	711	789	
LBE750P	750	73.5	86.4	124	170	195	213	248	266	307	324	336	378	441	560	615	762	846	
LBE830P	830	81.3	95.6	137	188	216	235	274	295	339	359	372	418	488	620	680	843	936	
LBE925P	925	90.7	107	153	209	241	262	305	329	378	400	414	466	544	691	758	940	1043	
LBE1020P	1020	100	118	169	231	265	289	337	362	417	441	457	514	600	762	836	1036	1150	
LBE1100P	1100	108	127	182	249	286	312	363	391	450	475	493	554	647	822	901	1118	1240	
LBE1200P	1200	118	138	199	271	312	340	396	426	491	518	538	605	706	897	983	1219	1353	
LBE1300P	1300	127	150	215	294	338	369	429	462	531	562	582	655	764	971	1065	1321	1466	
LBE1400P	1400	137	161	232	317	364	397	462	497	572	605	627	706	823	1046	1147	1422	1578	
LBE1500P	1500	147	173	248	339	390	426	495	533	613	648	672	756	882	1121	1229	1524	1691	
LBE1600P	1600	157	184	265	362	416	454	528	568	654	691	717	806	941	1196	1311	1626	1804	
LBE1660P	1660	163	191	275	375	432	471	548	590	679	717	744	837	976	1240	1360	1687	1872	

M Range

Cell dimensions and internal resistance

M cells are normally supplied as single cells, taped together into blocks or assembled in steel crates.

Cell type	Capacity at the 5hr rate (Ah)	Volume of liquid electrolyte above plates (cc)	Approx. weight per cell		Overall height		Width per cell		Length per cell		Internal resistance (mOhm)	Electrolyte height between Min - Max (mm)
			(kg)	(lbs)	(mm)	H (ins)	(mm)	W (ins)	(mm)	L (ins)		
MC9P	9	146	1.6	3.6	275	10.83	121	4.76	42	1.65	6.89	35
MC14P	14	146	1.7	3.7	275	10.83	121	4.76	42	1.65	4.43	35
MC22P	22	143	1.9	4.2	275	10.83	121	4.76	42	1.65	2.82	35
MC31P	31	140	2.1	4.6	275	10.83	121	4.76	42	1.65	2.00	35
MC39P	39	235	3.1	6.8	275	10.83	121	4.76	66	2.60	1.59	35
MC47P	47	232	3.3	7.2	275	10.83	121	4.76	66	2.60	1.32	35
MC55P	55	230	3.5	7.6	275	10.83	121	4.76	66	2.60	1.13	35
MC70P	70	552	6.3	13.8	358	14.09	192	7.56	68	2.68	1.11	35
MC90P	90	546	6.6	14.4	358	14.09	192	7.56	68	2.68	0.87	50
MC110P	110	539	7.2	15.9	358	14.09	192	7.56	68	2.68	0.71	50
MC130P	130	532	7.7	16.9	358	14.09	192	7.56	68	2.68	0.60	50
MC145P	145	758	9.9	21.7	358	14.09	192	7.56	93	3.66	0.54	50
MC165P	165	751	10.3	22.7	358	14.09	192	7.56	93	3.66	0.47	50
MC185P	185	744	10.7	23.5	358	14.09	192	7.56	93	3.66	0.42	50
MC215P	215	751	13.1	28.8	414	16.30	192	7.56	93	3.66	0.40	50
MC240P	240	744	13.5	29.7	414	16.30	192	7.56	93	3.66	0.36	50
MC285P	285	1005	17.2	38.0	414	16.30	192	7.56	122	4.80	0.30	50
MC310P	310	996	17.7	38.9	414	16.30	192	7.56	122	4.80	0.28	50
MC335P	335	989	18.2	40.1	414	16.30	192	7.56	122	4.80	0.26	50
MB370P	369	1200	19.5	42.9	405	15.94	195	7.68	159	6.26	0.23	50
MB390P	392	1300	21.0	46.2	405	15.94	195	7.68	171	6.73	0.22	50
MB415P	415	1400	23.0	50.6	405	15.94	195	7.68	183	7.20	0.21	50
MB440P	438	1400	23.5	51.7	405	15.94	195	7.68	183	7.20	0.20	50
MB460P	461	1400	24.0	52.8	405	15.94	195	7.68	183	7.20	0.19	50
MB505P	505	1600	27.5	60.5	405	15.94	195	7.68	213	8.39	0.17	50
MB555P	555	1800	30.0	66.0	405	15.94	195	7.68	232	9.13	0.15	50
MB625P	625	2100	34.5	75.9	405	15.94	195	7.68	268	10.55	0.14	50
MB690P	690	2100	36.0	79.2	405	15.94	195	7.68	268	10.55	0.12	50
MB740P	740	2400	40.0	88.0	405	15.94	195	7.68	304	11.97	0.12	50
MB830P	830	2800	46.0	101.2	405	15.94	195	7.68	352	13.86	0.10	50
MB920P	920	2800	48.0	105.6	405	15.94	195	7.68	352	13.86	0.09	50
MB965P	965	3000	50.5	111.1	405	15.94	195	7.68	372	14.65	0.09	50
MB1040P	1040	3500	57.5	126.5	405	15.94	195	7.68	437	17.20	0.08	50
MB1150P	1150	3500	60.0	132.0	405	15.94	195	7.68	437	17.20	0.07	50
MB1220P	1220	4100	67.5	148.5	405	15.94	195	7.68	510	20.08	0.07	50
MB1390P	1390	4200	72.0	158.4	405	15.94	195	7.68	522	20.55	0.06	50

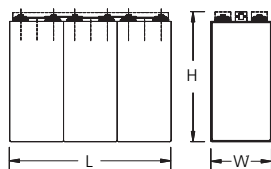
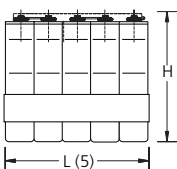

MC9P - MC335P
Taped block length =
cell length x no of cells + 2mm/0.1 in.

MB370P - MB1390P

Cell connection bolt per pole:	MB370P to MB460P: 2 x M10
	MB505P to MB690P: 3 x M10
MC9P to MC55P: M6	MB740P to MB920P: 4 x M10
MC70P & MC90P: M8	MB965P: 6 x M10
MC110P to MC240P: M10	MB1040P & MB1150P: 5 x M10
MC285P to MC335P: 2 x M10	MB1120P to MB1390P: 6 x M10

Cell performance

M Range

Available amperes at +20°C ± 5°C (+68°F ± 9°F)
Performance after prolonged float charge of fully charged cells

Final voltage: 1.00 V/cell

Cell type	C ₅ Ah	HOURS				MINUTES								SECONDS		
		8 h	5 h	3 h	2 h	90 min	60 min	30 min	20 min	15 min	10 min	5 min	1 min	30 s	5 s	1 s
MC9P	9	1.13	1.80	2.94	4.29	5.15	6.66	9.00	10.6	11.5	13.0	15.9	22.7	25.6	30.8	32.6
MC14P	14	1.76	2.80	4.58	6.68	8.02	10.4	14.0	16.4	17.9	20.3	24.7	35.3	39.8	47.9	50.7
MC22P	22	2.77	4.40	7.19	10.5	12.6	16.3	22.0	25.8	28.2	31.8	38.9	55.4	62.5	75.3	79.7
MC31P	31	3.91	6.20	10.1	14.8	17.8	22.9	31.0	36.3	39.7	44.9	54.8	78.1	88.1	106	112
MC39P	39	4.91	7.80	12.8	18.6	22.3	28.8	39.0	45.7	49.9	56.4	68.9	98.2	111	134	141
MC47P	47	5.92	9.40	15.4	22.4	26.9	34.8	47.0	55.1	60.2	68.0	83.0	118	134	161	170
MC55P	55	6.93	11.0	18.0	26.2	31.5	40.7	55.0	64.5	70.4	79.6	97.2	139	156	188	199
MC70P	70	8.82	14.0	22.9	33.5	40.4	52.4	74.6	87.3	95.8	109	133	188	213	258	276
MC90P	90	11.3	18.0	29.4	43.0	51.9	67.3	95.9	112	123	140	171	241	274	332	354
MC110P	110	13.9	22.0	36.0	52.6	63.4	82.3	117	137	150	171	209	295	334	406	433
MC130P	130	16.4	26.0	42.5	62.1	75.0	97.2	139	162	178	202	247	349	395	480	512
MC145P	145	18.3	29.0	47.4	69.3	83.6	108	155	181	198	225	275	389	441	535	571
MC165P	165	20.8	33.0	54.0	78.9	95.2	123	176	206	226	256	313	442	502	609	650
MC185P	185	23.3	37.0	60.5	88.4	107	138	197	231	253	287	351	496	562	683	728
MC215P	215	27.1	43.0	70.3	103	124	161	228	266	291	329	397	554	620	739	782
MC240P	240	30.2	48.0	78.5	115	138	180	254	297	325	367	444	619	692	825	873
MC285P	285	35.9	57.0	93.2	136	164	213	302	353	386	436	527	735	821	979	1036
MC310P	310	39.1	62.0	101	148	179	232	328	384	419	474	573	799	893	1065	1127
MC335P	335	42.2	67.0	110	160	193	251	354	415	453	512	619	863	965	1151	1218
MB370P	369	46.5	73.8	121	176	213	276	390	457	499	564	682	951	1063	1268	1342
MB390P	392	49.4	78.4	128	187	226	293	415	485	530	599	725	1010	1130	1347	1425
MB415P	415	52.3	83.0	136	198	239	310	439	514	562	635	767	1070	1196	1426	1509
MB440P	438	55.2	87.6	143	209	253	328	463	542	593	670	810	1129	1262	1505	1593
MB460P	461	58.1	92.2	151	220	266	345	488	571	624	705	852	1188	1329	1584	1676
MB505P	505	63.6	101	165	241	291	378	534	625	683	772	933	1302	1455	1735	1836
MB555P	555	69.9	111	181	265	320	415	587	687	751	849	1026	1430	1599	1907	2018
MB625P	625	78.7	125	204	299	360	467	661	774	846	956	1155	1611	1801	2148	2273
MB690P	690	86.9	138	226	330	398	516	730	854	934	1055	1275	1778	1988	2371	2509
MB740P	740	93.2	148	242	354	427	553	783	916	1001	1131	1368	1907	2133	2543	2691
MB830P	830	105	166	271	397	479	621	878	1027	1123	1269	1534	2139	2392	2852	3018
MB920P	920	116	184	301	440	531	688	974	1139	1245	1407	1701	2371	2651	3162	3345
MB965P	965	122	193	316	461	557	722	1021	1194	1306	1476	1784	2487	2781	3316	3509
MB1040P	1040	131	208	340	497	600	778	1101	1287	1407	1590	1922	2680	2997	3574	3782
MB1150P	1150	145	230	376	550	663	860	1217	1423	1556	1758	2126	2964	3314	3952	4182
MB1220P	1220	154	244	399	583	704	912	1291	1510	1651	1865	2255	3144	3516	4192	4436
MB1390P	1390	175	278	455	664	802	1040	1471	1720	1881	2125	2569	3582	4006	4777	5055

M Range Cell performance

Available amperes at +20°C ± 5°C (+68°F ± 9°F)
Performance after prolonged float charge of fully charged cells

Final voltage: 1.05 V/cell

Cell type	C ₅ Ah	HOURS				MINUTES								SECONDS		
		8 h	5 h	3 h	2 h	90 min	60 min	30 min	20 min	15 min	10 min	5 min	1 min	30 s	5 s	1 s
MC9P	9	1.13	1.78	2.90	3.78	4.53	5.83	7.65	8.69	9.65	11.0	13.2	18.6	21.1	25.0	26.9
MC14P	14	1.75	2.77	4.51	5.87	7.05	9.07	11.9	13.5	15.0	17.1	20.5	28.9	32.8	38.9	41.9
MC22P	22	2.75	4.36	7.08	9.23	11.1	14.2	18.7	21.2	23.6	26.9	32.2	45.4	51.5	61.1	65.9
MC31P	31	3.88	6.14	9.98	13.0	15.6	20.1	26.4	29.9	33.2	37.9	45.3	63.9	72.6	86.1	92.8
MC39P	39	4.88	7.72	12.6	16.4	19.6	25.3	33.2	37.6	41.8	47.7	57.0	80.4	91.3	108	117
MC47P	47	5.88	9.31	15.1	19.7	23.7	30.4	40.0	45.4	50.4	57.5	68.7	96.9	110	131	141
MC55P	55	6.88	10.9	17.7	23.1	27.7	35.6	46.8	53.1	58.9	67.3	80.4	113	129	153	165
MC70P	70	8.75	13.9	22.6	29.5	35.7	47.1	63.3	71.8	79.3	91.5	110	155	175	211	227
MC90P	90	11.3	17.8	29.1	37.9	45.9	60.5	81.4	92.3	102	118	141	199	226	272	291
MC110P	110	13.8	21.8	35.5	46.3	56.1	74.0	99.5	113	125	144	172	243	276	332	356
MC130P	130	16.3	25.7	42.0	54.8	66.3	87.4	118	133	147	170	204	288	326	393	421
MC145P	145	18.1	28.7	46.8	61.1	73.9	97.5	131	149	164	190	227	321	363	438	469
MC165P	165	20.6	32.7	53.3	69.5	84.1	111	149	169	187	216	259	365	414	498	534
MC185P	185	23.1	36.6	59.8	77.9	94.3	124	167	190	210	242	290	409	464	559	599
MC215P	215	26.9	42.6	69.4	90.6	110	145	193	219	242	275	326	452	508	599	646
MC240P	240	30.0	47.5	77.5	101	122	161	215	244	270	307	364	504	567	669	721
MC285P	285	35.6	56.4	92.1	120	145	192	256	290	321	364	432	599	674	794	856
MC310P	310	38.8	61.4	100	131	158	208	278	316	349	396	470	651	733	864	931
MC335P	335	41.9	66.3	108	141	171	225	300	341	377	428	508	704	792	933	1006
MB370P	369	46.1	73.1	119	155	188	248	331	376	415	471	559	775	872	1028	1108
MB390P	392	49.0	77.6	127	165	200	264	352	399	441	501	594	824	927	1092	1177
MB415P	415	51.9	82.2	134	175	212	279	372	423	467	530	629	872	981	1156	1246
MB440P	438	54.8	86.7	141	184	223	295	393	446	493	559	664	920	1035	1220	1315
MB460P	461	57.6	91.3	149	194	235	310	413	469	519	589	698	968	1090	1284	1384
MB505P	505	63.1	100.0	163	213	258	340	453	514	568	645	765	1061	1194	1407	1517
MB555P	555	69.4	110	179	234	283	373	498	565	624	709	841	1166	1312	1546	1667
MB625P	625	78.1	124	202	263	319	420	561	636	703	798	947	1313	1478	1741	1877
MB690P	690	86.3	137	223	291	352	464	619	703	776	881	1045	1450	1631	1922	2072
MB740P	740	92.5	147	239	312	377	498	664	754	832	945	1121	1555	1749	2061	2222
MB830P	830	104	164	268	350	423	558	744	845	934	1060	1258	1744	1962	2312	2492
MB920P	920	115	182	297	388	469	619	825	937	1035	1175	1394	1933	2175	2563	2763
MB965P	965	121	191	312	406	492	649	865	983	1085	1232	1462	2027	2281	2688	2898
MB1040P	1040	130	206	336	438	530	699	933	1059	1170	1328	1576	2185	2459	2897	3123
MB1150P	1150	144	228	371	484	586	773	1031	1171	1294	1469	1742	2416	2719	3203	3453
MB1220P	1220	153	242	394	514	622	820	1094	1242	1372	1558	1848	2563	2884	3398	3664
MB1390P	1390	174	275	449	586	709	935	1247	1415	1564	1775	2106	2920	3286	3872	4174

Cell performance

M Range

Available amperes at +20°C ± 5°C (+68°F ± 9°F)
Performance after prolonged float charge of fully charged cells

Final voltage: 1.10 V/cell

Cell type	C ₅ Ah	HOURS				MINUTES								SECONDS		
		8 h	5 h	3 h	2 h	90 min	60 min	30 min	20 min	15 min	10 min	5 min	1 min	30 s	5 s	1 s
MC9P	9	1.11	1.76	2.61	3.35	3.98	4.85	6.26	7.23	7.84	8.81	10.7	15.2	16.9	20.1	21.4
MC14P	14	1.72	2.73	4.06	5.21	6.18	7.55	9.74	11.2	12.2	13.7	16.6	23.6	26.4	31.3	33.3
MC22P	22	2.71	4.29	6.38	8.19	9.72	11.9	15.3	17.7	19.2	21.5	26.1	37.0	41.4	49.2	52.4
MC31P	31	3.81	6.05	9.00	11.5	13.7	16.7	21.6	24.9	27.0	30.4	36.8	52.2	58.4	69.4	73.8
MC39P	39	4.80	7.61	11.3	14.5	17.2	21.0	27.1	31.3	34.0	38.2	46.3	65.7	73.4	87.2	92.9
MC47P	47	5.78	9.17	13.6	17.5	20.8	25.3	32.7	37.8	40.9	46.0	55.8	79.1	88.5	105	112
MC55P	55	6.77	10.7	16.0	20.5	24.3	29.6	38.2	44.2	47.9	53.9	65.2	92.6	104	123	131
MC70P	70	8.61	13.7	20.4	26.3	31.6	39.3	51.3	59.8	65.0	73.1	88.5	125	142	168	194
MC90P	90	11.1	17.6	26.2	33.8	40.6	50.6	65.9	76.9	83.6	93.9	114	161	182	216	249
MC110P	110	13.5	21.5	32.0	41.3	49.6	61.8	80.6	93.9	102	115	139	197	223	264	305
MC130P	130	16.0	25.4	37.8	48.8	58.7	73.1	95.2	111	121	136	164	233	263	312	360
MC145P	145	17.8	28.3	42.2	54.4	65.4	81.5	106	124	135	151	183	259	294	348	402
MC165P	165	20.3	32.2	48.0	62.0	74.5	92.7	121	141	153	172	209	295	334	396	457
MC185P	185	22.8	36.1	53.9	69.5	83.5	104	136	158	172	193	234	331	374	444	512
MC215P	215	26.4	41.9	62.6	80.7	97.0	121	156	181	195	220	263	366	409	482	512
MC240P	240	29.5	46.8	69.9	90.1	108	135	174	202	218	245	293	409	456	538	571
MC285P	285	35.1	55.6	83.0	107	129	160	207	239	259	291	348	486	542	639	679
MC310P	310	38.1	60.5	90.2	116	140	174	225	260	281	317	379	528	589	695	738
MC335P	335	41.2	65.3	97.5	126	151	188	243	281	304	343	409	571	637	751	798
MB370P	369	45.4	72.0	107	139	167	207	268	310	335	377	451	629	702	827	879
MB390P	392	48.2	76.4	114	147	177	220	284	329	356	401	479	668	745	879	933
MB415P	415	51.0	80.9	121	156	187	233	301	348	377	424	507	707	789	930	988
MB440P	438	53.9	85.4	128	164	198	246	318	368	397	448	535	746	833	982	1043
MB460P	461	56.7	89.9	134	173	208	259	334	387	418	471	563	785	876	1034	1098
MB505P	505	62.1	98.5	147	190	228	284	366	424	458	516	617	860	960	1132	1202
MB555P	555	68.3	108	162	208	250	312	402	466	504	567	678	945	1055	1244	1321
MB625P	625	76.9	122	182	235	282	351	453	525	567	639	763	1065	1188	1401	1488
MB690P	690	84.9	135	201	259	311	388	500	579	626	706	842	1175	1312	1547	1643
MB740P	740	91.0	144	215	278	334	416	537	621	672	757	904	1261	1407	1659	1762
MB830P	830	102	162	242	312	375	467	602	697	753	849	1013	1414	1578	1861	1976
MB920P	920	113	179	268	345	415	517	667	772	835	941	1123	1567	1749	2063	2190
MB965P	965	119	188	281	362	435	542	700	810	876	987	1178	1644	1835	2164	2298
MB1040P	1040	128	203	303	391	469	585	754	873	944	1063	1270	1772	1977	2332	2476
MB1150P	1150	141	224	335	432	519	646	834	966	1044	1176	1404	1959	2186	2578	2738
MB1220P	1220	150	238	355	458	551	686	885	1024	1107	1247	1490	2078	2319	2735	2905
MB1390P	1390	171	271	405	522	627	781	1008	1167	1261	1421	1697	2368	2643	3117	3310

M Range Cell performance

Available amperes at +20°C ± 5°C (+68°F ± 9°F)
 Performance after prolonged float charge of fully charged cells

Final voltage: 1.14 V/cell

Cell type	C ₅ Ah	HOURS				MINUTES								SECONDS		
		8 h	5 h	3 h	2 h	90 min	60 min	30 min	20 min	15 min	10 min	5 min	1 min	30 s	5 s	1 s
MC9P	9	1.08	1.69	2.29	2.87	3.37	3.89	5.03	5.75	6.27	7.18	8.62	12.2	13.7	15.9	16.5
MC14P	14	1.68	2.63	3.56	4.46	5.25	6.05	7.83	8.95	9.76	11.2	13.4	18.9	21.3	24.8	25.6
MC22P	22	2.64	4.14	5.59	7.01	8.25	9.50	12.3	14.1	15.3	17.5	21.1	29.8	33.4	38.9	40.2
MC31P	31	3.72	5.83	7.88	9.88	11.6	13.4	17.3	19.8	21.6	24.7	29.7	41.9	47.1	54.9	56.7
MC39P	39	4.68	7.33	9.91	12.4	14.6	16.8	21.8	24.9	27.2	31.1	37.4	52.8	59.3	69.0	71.3
MC47P	47	5.64	8.84	11.9	15.0	17.6	20.3	26.3	30.1	32.8	37.5	45.0	63.6	71.4	83.2	85.9
MC55P	55	6.60	10.3	14.0	17.5	20.6	23.8	30.7	35.2	38.3	43.9	52.7	74.4	83.6	97.3	101
MC70P	70	8.40	13.2	17.8	22.7	27.0	31.7	41.1	47.1	52.0	59.1	71.3	102	114	134	139
MC90P	90	10.8	16.9	22.9	29.2	34.8	40.8	52.8	60.6	66.9	75.9	91.6	131	147	172	179
MC110P	110	13.2	20.7	28.0	35.7	42.5	49.9	64.5	74.1	81.8	92.8	112	161	180	210	219
MC130P	130	15.6	24.4	33.1	42.1	50.2	59.0	76.2	87.5	96.7	110	132	190	212	248	258
MC145P	145	17.4	27.3	37.0	47.0	56.0	65.8	85.0	97.6	108	122	148	212	237	277	288
MC165P	165	19.8	31.0	42.1	53.5	63.7	74.8	96.8	111	123	139	168	241	270	315	328
MC185P	185	22.2	34.8	47.2	60.0	71.5	83.9	109	125	138	156	188	270	302	353	368
MC215P	215	25.8	40.4	54.8	69.5	82.9	97.5	125	143	156	177	212	297	330	381	392
MC240P	240	28.8	45.1	61.2	77.6	92.5	109	139	160	174	198	236	331	368	425	438
MC285P	285	34.2	53.6	72.7	92.2	110	129	165	190	206	235	281	393	437	504	520
MC310P	310	37.2	58.3	79.0	100	120	141	180	207	224	256	305	428	475	549	566
MC335P	335	40.2	63.0	85.4	108	129	152	194	223	242	276	330	462	514	593	611
MB370P	369	44.3	69.4	94.1	119	142	167	214	246	267	304	364	509	566	653	673
MB390P	392	47.0	73.7	100	127	151	178	227	261	284	323	386	541	601	694	715
MB415P	415	49.8	78.0	106	134	160	188	241	276	300	342	409	572	637	735	757
MB440P	438	52.6	82.3	112	142	169	199	254	292	317	361	432	604	672	775	799
MB460P	461	55.3	86.7	118	149	178	209	267	307	334	380	454	636	707	816	841
MB505P	505	60.6	94.9	129	163	195	229	293	336	365	416	498	697	775	894	922
MB555P	555	66.6	104	142	179	214	252	322	370	402	458	547	766	851	982	1013
MB625P	625	75.0	118	159	202	241	283	362	416	452	515	616	862	959	1106	1141
MB690P	690	82.8	130	176	223	266	313	400	460	499	569	680	952	1058	1221	1259
MB740P	740	88.8	139	189	239	285	336	429	493	535	610	729	1021	1135	1310	1350
MB830P	830	99.6	156	212	268	320	376	481	553	601	684	818	1145	1273	1469	1515
MB920P	920	110	173	235	298	355	417	533	613	666	758	906	1269	1411	1628	1679
MB965P	965	116	181	246	312	372	438	559	643	698	796	951	1331	1480	1708	1761
MB1040P	1040	125	196	265	336	401	472	603	693	753	857	1025	1434	1595	1841	1898
MB1150P	1150	138	216	293	372	443	522	667	766	832	948	1133	1586	1764	2035	2099
MB1220P	1220	146	229	311	395	470	553	707	813	883	1006	1202	1683	1871	2159	2226
MB1390P	1390	167	261	354	450	536	630	806	926	1006	1146	1369	1917	2132	2460	2536

Cell dimensions and internal resistance

H Range

H cells are normally supplied as single cells, taped together into blocks or assembled in steel crates.

Cell type	Capacity at the 5hr rate (Ah)	Volume of liquid electrolyte above plates (cc)	Approx. weight per cell		Overall height		Width per cell		Length per cell		Internal resistance (mOhm)	Electrolyte height between Min - Max (mm)
			(kg)	(lb)	(mm)	H (ins)	(mm)	W (ins)	(mm)	L (ins)		
HC9P	9	143	1.8	3.9	275	10.83	121	4.76	42	1.65	3.33	35
HC12P	12	140	1.9	4.2	275	10.83	121	4.76	42	1.65	2.50	35
HC17P	17	138	2.1	4.5	275	10.83	121	4.76	42	1.65	1.76	35
HC21P	21	232	3.0	6.6	275	10.83	121	4.76	66	2.60	1.43	35
HC25P	25	230	3.2	6.9	275	10.83	121	4.76	66	2.60	1.20	35
HC29P	29	227	3.3	7.3	275	10.83	121	4.76	66	2.60	1.03	35
HC34P	34	224	3.5	7.6	275	10.83	121	4.76	66	2.60	0.88	35
HC40P	40	546	6.2	13.7	358	14.09	192	7.56	68	2.68	0.98	50
HC50P	50	539	6.6	14.5	358	14.09	192	7.56	68	2.68	0.78	50
HC60P	60	532	7.0	15.4	358	14.09	192	7.56	68	2.68	0.65	50
HC70P	70	525	7.4	16.2	358	14.09	192	7.56	68	2.68	0.56	50
HC80P	80	518	7.7	17.0	358	14.09	192	7.56	68	2.68	0.49	50
HC90P	90	744	9.8	21.6	358	14.09	192	7.56	93	3.66	0.43	50
HC100P	100	737	10.1	22.2	358	14.09	192	7.56	93	3.66	0.39	50
HC110P	110	731	10.5	23.1	358	14.09	192	7.56	93	3.66	0.35	50
HC120P	120	724	10.8	23.8	358	14.09	192	7.56	93	3.66	0.33	50
HC130P	130	737	12.8	28.3	414	16.30	192	7.56	93	3.66	0.33	50
HC145P	145	731	13.2	29.0	414	16.30	192	7.56	93	3.66	0.30	50
HC155P	155	724	13.5	29.8	414	16.30	192	7.56	93	3.66	0.28	50
HC185P	185	976	17.5	38.5	414	16.30	192	7.56	122	4.80	0.23	50
HC210P	210	962	18.2	40.0	414	16.30	192	7.56	122	4.80	0.20	50
HB230P	230	1200	20.0	44.0	405	15.94	195	7.68	159	6.26	0.19	50
HB255P	256	1200	21.0	46.2	405	15.94	195	7.68	159	6.26	0.17	50
HB280P	281	1400	23.5	51.7	405	15.94	195	7.68	183	7.20	0.15	50
HB305P	307	1400	24.5	53.9	405	15.94	195	7.68	183	7.20	0.14	50
HB345P	345	1800	29.5	64.9	405	15.94	195	7.68	232	9.13	0.12	50
HB385P	383	1700	31.0	68.2	405	15.94	195	7.68	232	9.13	0.11	50
HB420P	422	2100	34.5	75.9	405	15.94	195	7.68	268	10.55	0.10	50
HB460P	460	2100	36.0	79.2	405	15.94	195	7.68	268	10.55	0.09	50
HB510P	510	2300	42.0	92.4	405	15.94	195	7.68	304	11.97	0.08	50
HB560P	560	2800	46.0	101.2	405	15.94	195	7.68	352	13.86	0.08	50
HB615P	615	2800	48.0	105.6	405	15.94	195	7.68	352	13.86	0.07	50
HB640P	640	2900	52.5	115.5	405	15.94	195	7.68	377	14.84	0.07	50
HB705P	705	3500	57.5	126.5	405	15.94	195	7.68	437	17.20	0.06	50
HB765P	765	3500	60.0	132.0	405	15.94	195	7.68	437	17.20	0.06	50
HB865P	865	4000	68.5	150.7	405	15.94	195	7.68	497	19.57	0.05	50
HB920P	920	4200	72.0	158.4	405	15.94	195	7.68	522	20.55	0.05	50

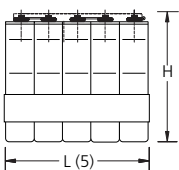

HC9P - HC210P
Taped block length =
cell length x no of cells + 2mm/0.1 in.

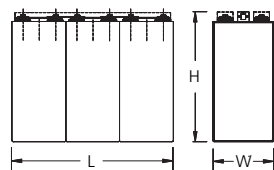

HB230P - HB920P

Cell connection bolt per pole:	HB230P to HB305P:	2 x M10	
HC9P to HC34P:	M6	HB345P to HB460P:	3 x M10
HC40P & HC50P:	M8	HB510P to HB615P:	4 x M10
HC60P to HC155P:	M10	HB640P to HB765P:	5 x M10
HC185P & HC210P:	2 x M10	HB865P & HB920P:	6 x M10

H Range Cell performance

Available amperes at +20°C ± 5°C (+68°F ± 9°F)
 Performance after prolonged float charge of fully charged cells

Final voltage: 1.00 V/cell

Cell type	C ₅ Ah	HOURS				MINUTES								SECONDS		
		8 h	5 h	3 h	2 h	90 min	60 min	30 min	20 min	15 min	10 min	5 min	1 min	30 s	5 s	1 s
HC9P	9	1.13	1.80	2.96	4.39	5.78	8.46	15.3	20.4	23.0	26.2	31.6	46.6	52.6	66.7	70.9
HC12P	12	1.50	2.40	3.95	5.86	7.70	11.3	20.4	27.2	30.7	34.9	42.1	62.2	70.2	88.9	94.5
HC17P	17	2.13	3.40	5.59	8.30	10.9	16.0	28.9	38.5	43.5	49.4	59.6	88.1	99.4	126	134
HC21P	21	2.63	4.20	6.91	10.2	13.5	19.7	35.7	47.6	53.7	61.0	73.7	109	123	156	165
HC25P	25	3.13	5.00	8.22	12.2	16.0	23.5	42.5	56.7	63.9	72.7	87.7	130	146	185	197
HC29P	29	3.63	5.80	9.54	14.2	18.6	27.3	49.3	65.8	74.2	84.3	102	150	170	215	228
HC34P	34	4.25	6.80	11.2	16.6	21.8	32.0	57.8	77.1	87.0	98.8	119	176	199	252	268
HC40P	40	5.00	8.00	13.2	19.5	25.7	37.6	68.8	92.8	106	120	145	206	235	296	325
HC50P	50	6.25	10.0	16.5	24.4	32.2	47.0	86.1	116	132	150	181	258	294	370	407
HC60P	60	7.50	12.0	19.7	29.3	38.6	56.4	103	139	158	180	217	309	353	444	488
HC70P	70	8.75	14.0	23.0	34.2	45.0	65.8	120	162	185	210	254	361	412	519	569
HC80P	80	10.0	16.0	26.3	39.0	51.4	75.2	138	186	211	240	290	412	471	593	650
HC90P	90	11.3	18.0	29.6	43.9	57.9	84.6	155	209	237	270	326	464	529	667	732
HC100P	100	12.5	20.0	32.9	48.8	64.3	94.0	172	232	264	300	362	515	588	741	813
HC110P	110	13.8	22.0	36.2	53.7	70.7	103	189	255	290	330	399	567	647	815	894
HC120P	120	15.0	24.0	39.5	58.6	77.2	113	207	278	317	360	435	619	706	889	976
HC130P	130	16.3	26.0	42.8	63.4	83.5	122	222	298	335	377	445	615	694	844	897
HC145P	145	18.1	29.0	47.7	70.8	93.1	136	247	333	374	421	496	686	774	941	1001
HC155P	155	19.4	31.0	51.0	75.6	99.5	146	265	355	399	450	531	733	827	1006	1070
HC185P	185	23.1	37.0	60.9	90.3	119	174	316	424	477	537	633	875	987	1200	1277
HC210P	210	26.3	42.0	69.1	102	135	197	358	482	541	609	719	993	1121	1363	1449
HB230P	230	28.8	46.0	75.7	112	148	216	393	528	593	668	788	1088	1228	1493	1588
HB255P	255	31.9	51.0	83.9	124	164	240	435	585	657	740	873	1206	1361	1655	1760
HB280P	280	35.0	56.0	92.1	137	180	263	478	642	721	813	959	1324	1494	1817	1933
HB305P	305	38.1	61.0	100	149	196	287	520	700	786	885	1044	1442	1628	1979	2105
HB345P	345	43.1	69.0	114	168	221	324	589	791	889	1001	1181	1631	1841	2239	2381
HB385P	385	48.1	77.0	127	188	247	362	657	883	992	1117	1318	1820	2055	2498	2657
HB420P	420	52.5	84.0	138	205	270	395	717	963	1082	1219	1438	1986	2242	2725	2899
HB460P	460	57.5	92.0	151	224	295	432	785	1055	1185	1335	1575	2175	2455	2985	3175
HB510P	510	63.8	102	168	249	327	479	870	1170	1314	1480	1746	2411	2722	3309	3520
HB560P	560	70.0	112	184	273	360	526	956	1284	1443	1625	1917	2648	2989	3634	3865
HB615P	615	76.9	123	202	300	395	578	1050	1410	1584	1785	2106	2908	3282	3991	4245
HB640P	640	80.0	128	211	312	411	602	1092	1468	1649	1857	2191	3026	3416	4153	4417
HB705P	705	88.1	141	232	344	453	663	1203	1617	1816	2046	2414	3333	3763	4575	4866
HB765P	765	95.6	153	252	373	491	719	1305	1755	1971	2220	2619	3617	4083	4964	5280
HB865P	865	108	173	285	422	555	813	1476	1984	2228	2510	2962	4090	4616	5613	5970
HB920P	920	115	184	303	449	591	865	1570	2110	2370	2670	3150	4350	4910	5970	6350

Cell performance

H Range

Available amperes at +20°C ± 5°C (+68°F ± 9°F)
Performance after prolonged float charge of fully charged cells

Final voltage: 1.05 V/cell

Cell type	C ₅ Ah	HOURS				MINUTES								SECONDS		
		8 h	5 h	3 h	2 h	90 min	60 min	30 min	20 min	15 min	10 min	5 min	1 min	30 s	5 s	1 s
HC9P	9	1.12	1.77	2.92	4.30	5.65	8.19	14.5	17.4	19.2	21.7	25.9	38.5	45.2	55.2	59.6
HC12P	12	1.49	2.36	3.89	5.74	7.54	10.9	19.3	23.3	25.6	28.9	34.5	51.3	60.3	73.6	79.5
HC17P	17	2.11	3.35	5.51	8.13	10.7	15.5	27.4	32.9	36.2	41.0	48.9	72.6	85.4	104	113
HC21P	21	2.60	4.14	6.80	10.0	13.2	19.1	33.8	40.7	44.8	50.6	60.3	89.7	106	129	139
HC25P	25	3.10	4.93	8.10	12.0	15.7	22.7	40.3	48.4	53.3	60.2	71.8	107	126	153	166
HC29P	29	3.60	5.71	9.40	13.9	18.2	26.4	46.7	56.2	61.8	69.9	83.3	124	146	178	192
HC34P	34	4.22	6.70	11.0	16.3	21.4	30.9	54.8	65.9	72.5	81.9	97.7	145	171	209	225
HC40P	40	4.96	7.88	13.0	19.2	25.2	36.4	65.3	80.2	87.9	99.5	118	175	200	247	265
HC50P	50	6.20	9.85	16.2	24.0	31.4	45.5	81.6	100	110	124	147	219	250	309	331
HC60P	60	7.44	11.8	19.4	28.7	37.7	54.6	97.9	120	132	149	177	263	300	370	397
HC70P	70	8.68	13.8	22.7	33.5	44.0	63.7	114	140	154	174	206	307	350	432	464
HC80P	80	9.92	15.8	25.9	38.3	50.3	72.8	131	160	176	199	236	351	400	494	530
HC90P	90	11.2	17.7	29.2	43.1	56.6	81.9	147	180	198	224	265	395	450	556	596
HC100P	100	12.4	19.7	32.4	47.9	62.9	91.0	163	200	220	249	295	439	500	617	662
HC110P	110	13.6	21.7	35.6	52.7	69.2	100	179	220	242	274	324	482	550	679	728
HC120P	120	14.9	23.6	38.9	57.5	75.5	109	196	240	264	299	354	526	600	741	795
HC130P	130	16.1	25.6	42.1	62.3	81.6	118	211	256	277	311	362	516	582	702	732
HC145P	145	18.0	28.6	47.0	69.5	91.1	132	235	285	309	347	403	575	649	783	816
HC155P	155	19.2	30.5	50.2	74.2	97.3	141	251	305	330	371	431	615	694	837	873
HC185P	185	22.9	36.4	59.9	88.6	116	168	300	364	394	442	515	734	828	999	1042
HC210P	210	26.0	41.4	68.0	101	132	191	340	413	447	502	584	833	940	1134	1182
HB230P	230	28.5	45.3	74.5	110	144	209	373	453	490	550	640	913	1030	1243	1295
HB255P	255	31.6	50.2	82.6	122	160	232	413	502	543	610	710	1012	1142	1378	1436
HB280P	280	34.7	55.2	90.7	134	176	255	453	551	597	670	779	1111	1254	1513	1577
HB305P	305	37.8	60.1	98.8	146	192	278	494	600	650	729	849	1210	1366	1648	1717
HB345P	345	42.8	68.0	112	165	217	314	559	679	735	825	960	1369	1545	1864	1943
HB385P	385	47.7	75.8	125	184	242	350	624	757	820	921	1071	1527	1724	2080	2168
HB420P	420	52.1	82.7	136	201	264	382	680	826	895	1004	1169	1666	1881	2269	2365
HB460P	460	57.0	90.6	149	220	289	419	745	905	980	1100	1280	1825	2060	2485	2590
HB510P	510	63.2	100	165	244	320	464	826	1003	1087	1220	1419	2023	2284	2755	2872
HB560P	560	69.4	110	181	268	352	510	907	1102	1193	1339	1558	2222	2508	3025	3153
HB615P	615	76.3	121	199	295	386	560	996	1210	1310	1471	1711	2440	2754	3322	3463
HB640P	640	79.4	126	207	307	402	582	1037	1259	1363	1530	1781	2539	2866	3457	3603
HB705P	705	87.4	139	228	338	443	642	1142	1387	1502	1686	1962	2797	3157	3809	3969
HB765P	765	94.9	151	248	366	480	696	1239	1505	1630	1829	2129	3035	3426	4133	4307
HB865P	865	107	170	280	414	543	787	1401	1702	1843	2068	2407	3432	3874	4673	4870
HB920P	920	114	181	298	441	578	837	1490	1810	1960	2200	2560	3650	4120	4970	5180

H Range

Cell performance

Available amperes at +20°C ± 5°C (+68°F ± 9°F)
Performance after prolonged float charge of fully charged cells

Final voltage: 1.10 V/cell

Cell type	C ₅ Ah	HOURS				MINUTES								SECONDS		
		8 h	5 h	3 h	2 h	90 min	60 min	30 min	20 min	15 min	10 min	5 min	1 min	30 s	5 s	1 s
HC9P	9	1.09	1.73	2.83	4.17	5.44	7.66	11.7	13.5	15.0	16.8	20.2	30.6	35.6	45.0	47.4
HC12P	12	1.45	2.30	3.78	5.56	7.26	10.2	15.6	18.0	20.0	22.3	26.9	40.8	47.4	60.0	63.2
HC17P	17	2.06	3.26	5.35	7.87	10.3	14.5	22.0	25.4	28.3	31.7	38.1	57.8	67.2	85.0	89.5
HC21P	21	2.54	4.03	6.61	9.72	12.7	17.9	27.2	31.4	35.0	39.1	47.1	71.4	83.0	105	111
HC25P	25	3.03	4.80	7.87	11.6	15.1	21.3	32.4	37.4	41.7	46.6	56.1	85.0	98.8	125	132
HC29P	29	3.51	5.57	9.13	13.4	17.5	24.7	37.6	43.4	48.3	54.0	65.0	98.6	115	145	153
HC34P	34	4.11	6.53	10.7	15.7	20.6	28.9	44.1	50.9	56.7	63.3	76.2	116	134	170	179
HC40P	40	4.84	7.68	12.6	18.5	24.2	34.5	53.3	61.6	68.7	76.5	91.5	138	160	196	220
HC50P	50	6.05	9.60	15.8	23.2	30.3	43.1	66.7	77.0	85.9	95.6	114	173	200	245	275
HC60P	60	7.26	11.5	18.9	27.8	36.4	51.7	80.0	92.4	103	115	137	208	240	294	330
HC70P	70	8.47	13.4	22.1	32.4	42.4	60.3	93.3	108	120	134	160	242	280	343	385
HC80P	80	9.68	15.4	25.2	37.0	48.5	68.9	107	123	137	153	183	277	320	392	440
HC90P	90	10.9	17.3	28.4	41.7	54.5	77.5	120	139	155	172	206	311	360	441	495
HC100P	100	12.1	19.2	31.5	46.3	60.6	86.1	133	154	172	191	229	346	400	490	549
HC110P	110	13.3	21.1	34.7	50.9	66.7	94.7	147	169	189	210	252	381	440	539	604
HC120P	120	14.5	23.0	37.8	55.6	72.7	103	160	185	206	229	275	415	480	588	659
HC130P	130	15.7	25.0	41.0	60.2	78.7	112	171	194	215	237	278	411	468	557	585
HC145P	145	17.5	27.8	45.7	67.1	87.7	125	191	216	240	265	310	459	522	621	653
HC155P	155	18.8	29.8	48.8	71.8	93.8	134	204	231	256	283	332	490	558	664	698
HC185P	185	22.4	35.5	58.3	85.7	112	159	243	275	306	338	396	585	666	792	833
HC210P	210	25.4	40.3	66.2	97.2	127	181	276	313	347	383	450	664	756	899	945
HB230P	230	27.8	44.2	72.5	106	139	198	303	343	380	420	493	728	828	985	1035
HB255P	255	30.9	49.0	80.3	118	154	220	335	380	421	466	546	807	917	1092	1148
HB280P	280	33.9	53.8	88.2	130	169	241	368	417	463	511	600	886	1007	1199	1260
HB305P	305	36.9	58.6	96.1	141	185	263	401	454	504	557	653	965	1097	1306	1373
HB345P	345	41.7	66.2	109	160	209	297	454	514	570	630	739	1091	1241	1478	1553
HB385P	385	46.6	73.9	121	178	233	332	506	573	636	703	824	1218	1385	1649	1733
HB420P	420	50.8	80.6	132	194	254	362	552	625	694	767	899	1328	1511	1799	1890
HB460P	460	55.7	88.3	145	213	278	396	605	685	760	840	985	1455	1655	1970	2070
HB510P	510	61.7	97.9	161	236	309	439	671	759	843	931	1092	1613	1835	2184	2295
HB560P	560	67.8	108	176	259	339	482	737	834	925	1023	1199	1771	2015	2398	2520
HB615P	615	74.4	118	194	285	372	530	809	916	1016	1123	1317	1945	2213	2634	2768
HB640P	640	77.4	123	202	296	387	551	842	953	1057	1169	1370	2024	2303	2741	2880
HB705P	705	85.3	135	222	326	427	607	927	1050	1165	1287	1510	2230	2536	3019	3173
HB765P	765	92.6	147	241	354	463	659	1006	1139	1264	1397	1638	2420	2752	3276	3443
HB865P	865	105	166	272	400	523	745	1138	1288	1429	1580	1852	2736	3112	3704	3893
HB920P	920	111	177	290	426	557	792	1210	1370	1520	1680	1970	2910	3310	3940	4140

Cell performance

H Range

Available amperes at +20°C ± 5°C (+68°F ± 9°F)
Performance after prolonged float charge of fully charged cells

Final voltage: 1.14 V/cell

Cell type	C ₅ Ah	HOURS				MINUTES								SECONDS		
		8 h	5 h	3 h	2 h	90 min	60 min	30 min	20 min	15 min	10 min	5 min	1 min	30 s	5 s	1 s
HC9P	9	1.05	1.67	2.72	3.97	5.14	6.77	9.03	10.5	11.6	12.9	15.8	24.6	28.7	34.9	41.9
HC12P	12	1.40	2.22	3.62	5.29	6.86	9.02	12.0	14.0	15.4	17.2	21.1	32.8	38.2	46.5	55.8
HC17P	17	1.99	3.15	5.13	7.50	9.71	12.8	17.1	19.8	21.9	24.4	29.9	46.4	54.1	65.9	79.1
HC21P	21	2.46	3.89	6.34	9.26	12.0	15.8	21.1	24.5	27.0	30.1	36.9	57.4	66.9	81.4	97.7
HC25P	25	2.93	4.63	7.55	11.0	14.3	18.8	25.1	29.2	32.2	35.8	43.9	68.3	79.6	96.9	116
HC29P	29	3.39	5.37	8.76	12.8	16.6	21.8	29.1	33.8	37.3	41.5	51.0	79.2	92.4	112	135
HC34P	34	3.98	6.29	10.3	15.0	19.4	25.6	34.1	39.7	43.8	48.7	59.8	92.9	108	132	158
HC40P	40	4.68	7.40	12.1	17.7	22.9	30.5	41.2	48.0	52.8	58.5	71.4	111	128	160	168
HC50P	50	5.85	9.25	15.2	22.2	28.7	38.1	51.4	60.0	66.0	73.1	89.3	139	160	200	210
HC60P	60	7.02	11.1	18.2	26.6	34.4	45.7	61.7	71.9	79.2	87.7	107	166	192	240	252
HC70P	70	8.19	13.0	21.2	31.0	40.1	53.3	72.0	83.9	92.3	102	125	194	224	280	294
HC80P	80	9.36	14.8	24.2	35.4	45.8	60.9	82.3	95.9	106	117	143	222	256	320	336
HC90P	90	10.5	16.7	27.3	39.9	51.6	68.5	92.6	108	119	132	161	249	288	360	378
HC100P	100	11.7	18.5	30.3	44.3	57.3	76.2	103	120	132	146	179	277	321	400	420
HC110P	110	12.9	20.4	33.3	48.7	63.0	83.8	113	132	145	161	196	305	353	440	462
HC120P	120	14.0	22.2	36.4	53.2	68.8	91.4	123	144	158	175	214	332	385	480	504
HC130P	130	15.2	24.1	39.3	57.5	74.4	97.8	131	151	165	181	220	328	376	442	458
HC145P	145	17.0	26.8	43.8	64.1	82.9	109	146	169	184	202	246	366	419	493	511
HC155P	155	18.1	28.7	46.8	68.5	88.7	117	156	180	197	216	263	391	448	527	546
HC185P	185	21.6	34.2	55.9	81.8	106	139	186	215	235	257	314	467	535	629	652
HC210P	210	24.6	38.9	63.4	92.8	120	158	211	244	267	292	356	530	607	714	740
HB230P	230	26.9	42.6	69.5	102	132	173	232	268	293	320	390	580	665	783	810
HB255P	255	29.8	47.2	77.0	113	146	192	257	297	324	355	432	643	737	868	898
HB280P	280	32.8	51.8	84.6	124	160	211	282	326	356	390	475	706	810	953	986
HB305P	305	35.7	56.4	92.1	135	174	229	307	355	388	424	517	769	882	1038	1074
HB345P	345	40.4	63.8	104	152	197	259	347	401	439	480	585	870	998	1174	1215
HB385P	385	45.0	71.2	116	170	220	290	388	448	490	536	653	971	1113	1310	1356
HB420P	420	49.1	77.7	127	186	240	316	423	488	534	584	712	1059	1214	1429	1479
HB460P	460	53.8	85.1	139	203	263	346	463	535	585	640	780	1160	1330	1565	1620
HB510P	510	59.7	94.4	154	225	292	384	514	593	649	710	865	1286	1475	1735	1796
HB560P	560	65.5	104	169	248	320	421	564	651	712	779	950	1412	1619	1905	1972
HB615P	615	72.0	114	186	272	352	462	619	715	782	856	1043	1551	1778	2092	2166
HB640P	640	74.9	118	193	283	366	481	645	744	814	890	1085	1614	1850	2177	2254
HB705P	705	82.5	130	213	312	403	530	710	820	897	981	1195	1778	2038	2399	2483
HB765P	765	89.5	142	231	338	438	575	770	890	973	1064	1297	1929	2212	2603	2694
HB865P	865	101	160	261	382	495	650	871	1006	1100	1203	1467	2181	2501	2943	3046
HB920P	920	108	170	278	407	526	692	927	1070	1170	1280	1560	2320	2660	3130	3240

H Range

Cell performance for engine starting applications

Available amperes at +20°C ± 5°C (+68°F ± 9°F)

Performance for fully charged cells by a constant current charge according to IEC 60623 standard.

Final voltage: 0.65 V/cell

Cell type	C ₅ Ah	SECONDS					
		90 s	60 s	30 s	15 s	5 s	1 s
HC9P	9	85.7	96.1	111	129	144	162
HC12P	12	114	128	147	172	191	216
HC17P	17	162	181	209	244	271	306
HC21P	21	200	224	258	301	335	378
HC25P	25	238	267	307	359	399	450
HC29P	29	276	309	356	416	463	522
HC34P	34	324	363	418	488	542	612
HC40P	40	393	439	502	580	646	719
HC50P	50	491	548	627	725	808	899
HC60P	60	589	658	753	870	969	1080
HC70P	70	687	768	878	1010	1130	1260
HC80P	80	785	877	1000	1160	1290	1440
HC90P	90	883	987	1130	1300	1450	1620
HC100P	100	981	1100	1260	1450	1620	1800
HC110P	110	1080	1210	1380	1590	1780	1980
HC120P	120	1180	1320	1510	1740	1940	2160
HC130P	130	1210	1340	1500	1720	1880	2040
HC145P	145	1350	1490	1680	1920	2100	2280
HC155P	155	1440	1600	1790	2050	2250	2430
HC185P	185	1720	1910	2140	2440	2680	2900
HC210P	210	1950	2160	2430	2770	3040	3300
HB230P	230	2140	2370	2660	3040	3330	3610
HB255P	255	2370	2630	2950	3370	3700	4000
HB280P	280	2600	2880	3240	3700	4060	4400
HB305P	305	2840	3140	3530	4030	4420	4790
HB345P	345	3210	3550	3990	4560	5000	5420
HB385P	385	3580	3970	4450	5090	5580	6040
HB420P	420	3910	4330	4860	5550	6090	6590
HB460P	460	4280	4740	5320	6080	6670	7220
HB510P	510	4740	5250	5900	6740	7390	8010
HB560P	560	5210	5770	6470	7400	8120	8790
HB615P	615	5720	6330	7110	8120	8910	9660
HB640P	640	5950	6590	7400	8450	9280	10050
HB705P	705	6560	7260	8150	9310	10220	11070
HB765P	765	7120	7880	8840	10110	11090	12010
HB865P	865	8050	8910	10000	11430	12540	13580
HB920P	920	8560	9480	10640	12150	13330	14440

Final voltage: 0.85 V/cell

Cell type	C ₅ Ah	SECONDS					
		90 s	60 s	30 s	15 s	5 s	1 s
HC9P	9	66.5	74.0	84.1	98.7	110	121
HC12P	12	88.7	98.6	112	132	146	161
HC17P	17	126	140	159	186	207	228
HC21P	21	155	173	196	230	256	282
HC25P	25	185	205	234	274	305	335
HC29P	29	214	238	271	318	354	389
HC34P	34	251	279	318	373	415	456
HC40P	40	303	336	382	443	492	537
HC50P	50	379	419	477	554	615	671
HC60P	60	455	503	573	665	738	805
HC70P	70	531	587	668	776	861	940
HC80P	80	607	671	763	887	984	1070
HC90P	90	682	755	859	998	1110	1210
HC100P	100	758	839	954	1110	1230	1340
HC110P	110	834	923	1050	1220	1350	1480
HC120P	120	910	1010	1150	1330	1480	1610
HC130P	130	922	1010	1130	1280	1390	1510
HC145P	145	1030	1130	1260	1430	1550	1690
HC155P	155	1100	1200	1340	1530	1660	1800
HC185P	185	1310	1440	1610	1820	1980	2150
HC210P	210	1490	1630	1820	2070	2250	2440
HB230P	230	1630	1790	2000	2260	2460	2670
HB255P	255	1810	1980	2210	2510	2730	2970
HB280P	280	1990	2170	2430	2760	3000	3260
HB305P	305	2160	2370	2650	3000	3260	3550
HB345P	345	2450	2680	2990	3400	3690	4010
HB385P	385	2730	2990	3340	3790	4120	4480
HB420P	420	2980	3260	3640	4130	4490	4880
HB460P	460	3260	3570	3990	4530	4920	5350
HB510P	510	3620	3960	4420	5020	5460	5930
HB560P	560	3970	4350	4860	5510	5990	6510
HB615P	615	4360	4780	5330	6050	6580	7150
HB640P	640	4540	4970	5550	6300	6850	7440
HB705P	705	5000	5470	6110	6940	7540	8200
HB765P	765	5430	5940	6640	7530	8180	8900
HB865P	865	6140	6720	7500	8510	9250	10060
HB920P	920	6530	7140	7980	9060	9840	10700

Standard layouts

Alcad has developed a series of standard layouts by which a battery may be ordered. Whether the battery is being installed on a rack, in a cabinet or is simply free-standing, the same configuration principles can be applied. There are two ways to configure the battery. The first is the normal method and is used on all LCE..P, MC..P and HC..P cell types. The cell's length is used to calculate the row length, shown in figure 1. The second method is shown in figure 2. It is used on the majority of Alcad's LBE..P, MB..P and HB..P cells, where the cell is turned through 90° and then connected width-to-width. This is referred to as 'crosswise' mounted and its purpose is to minimise the installation's overall length.

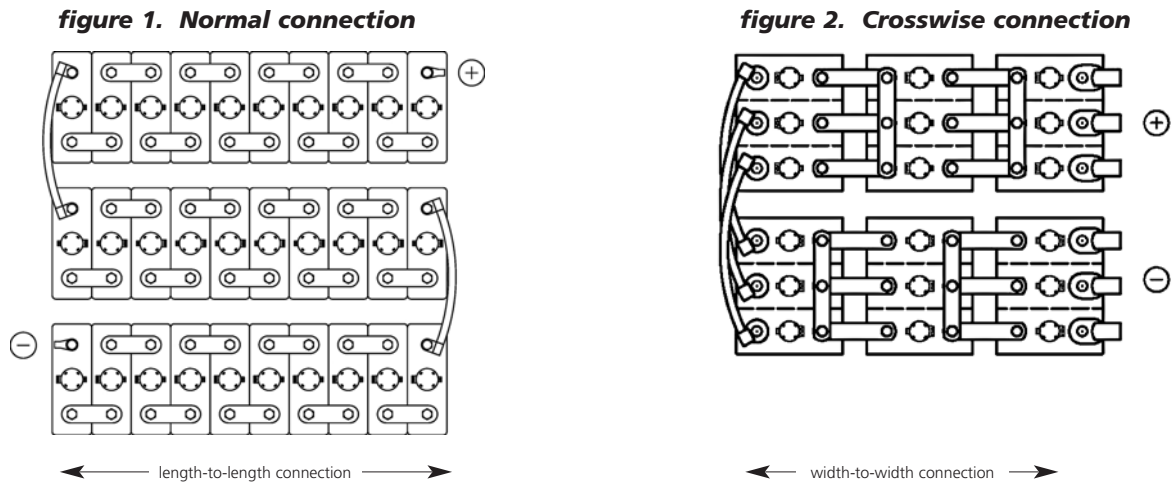

Table 1 demonstrates the connection method for Alcad's extended range of cells. All other designations utilise the normal method of connection (length-to-length).

Table 1

Connection type	LBE..P	MB..P	HB..P
Normal	LBE415P to LBE510P	MB370P to MB390P	-
Crosswise	LBE550P to LBE1660P	MB415P to MB1390P	HB230P to HB920P

Battery layout

Assembly method

Whatever your installation, use these simple guidelines when calculating your preferred configuration.

1. From the data in this publication, define the total number of cells in the battery.
2. Divide the length of the available installation area by the cell length (normal mount) or width (crosswise mount). This gives the maximum number of cells per row.
3. Divide the width (depth) of the available area by the cell width (normal mount) or length (crosswise mount). This will give the maximum number of rows.

For example

If we consider a cabinet with three shelves : each shelf has a length of 440 mm and a width 380 mm. The battery comprises of ninety cells type LCE30P, (figure 3).

figure 3.

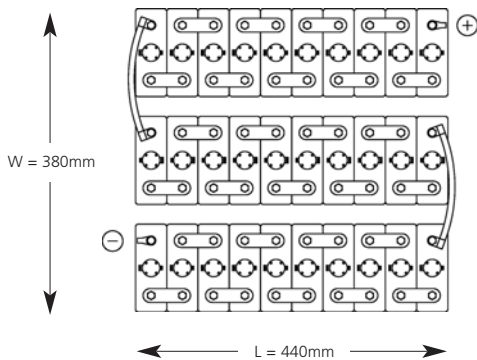

The LCE30P has length of 42 mm and width 121 mm.

$$\frac{440}{42} = 10 \text{ cells per row}$$

$$\frac{380}{121} = 3 \text{ rows per shelf}$$

A total of 30 cells can therefore be fitted on each shelf.

Whilst this is an ideal example, the calculation formula can be applied to all rack, cabinet and free-standing installations. For engineering assistance on complex layouts, please contact the company or its agent.

When ordering a battery rack, please specify the battery type and the preferred rack configuration (see pages 23-25). If your battery is being assembled in a cabinet, or is free-standing, please specify the number of rows, cells per row and total number of cells. This will ensure that all necessary inter-row and inter-tier flexible connectors are provided.

Battery racks

Alcad's product portfolio includes standard and anti-seismic battery racks (conforming to Uniform Building Code, Seismic Zone 4). These have been designed for all cell types in the Alcad range and are supplied unassembled to allow for easy installation. The purpose-built racks are strong, adaptable and provide good alkali protection.

Dimensions are given below for the range of rack layouts. Rack lengths are available in increments of 150 mm from 600 mm to a maximum of 6,000 mm. Calculate the required length using the cell length on page 5, 10, or 15 for normal connection, and by using the cell width 195 mm for crosswise connection.

1. Dimensions (mm) for single tier, standard floor mounted racks : single cell range

Cell type			1 tier rack					
LCE..P	MC..P	HC..P	Depth (D) No. of steps			Height (H) No. of steps		
			2	3	4	2	3	4
10 to 62	9 to 55	9 to 34	430	645	860	560	660	760
75 to 220	70 to 185	40 to 120	430	645	860	643	743	843
235 to 375	215 to 335	130 to 210	430	645	860	699	799	899

2. Dimensions (mm) for double tier, standard floor mounted racks : single cell range

Cell type			2 tier rack					
LCE..P	MC..P	HC..P	Depth (D) No. of steps			Height (H) No. of steps		
			2	3	4	2	3	4
10 to 62	9 to 55	9 to 34	500	715	930	1565	1665	1765
75 to 220	70 to 185	40 to 120	500	715	930	1648	1748	1848
235 to 375	215 to 335	130 to 210	500	715	930	1704	1804	1904

3. Dimensions (mm) for single tier, standard floor mounted racks : extended cell range

Cell type			1 tier rack								
LBE..P	MB..P	HB..P	1	Depth (D) No. of steps			4	1	Height (H) No. of steps		
				2	3	4			2	3	4
415 to 510*	370 to 390*	-	-	430	645	860	-	690	790	890	
550	415 to 460	230 to 305	-	430	645	860	-	690	790	890	
600 to 830	505 to 690	345 to 460	-	580	870	-	-	690	790	-	
925 to 1300	740 to 965	510 to 640	-	860	-	-	-	690	-	-	
1400 to 1660	1040 to 1390	705 to 920	580	1160	-	-	590	690	-	-	

* normal connection

4. Dimensions (mm) for double tier, standard floor mounted racks : extended cell range

Cell type			2 tier rack								
LBE..P	MB..P	HB..P	1	Depth (D) No. of steps			4	1	Height (H) No. of steps		
				2	3	4			2	3	4
415 to 510*	370 to 390*	-	-	500	715	930	-	1695	1795	1895	
550	415 to 460	230 to 305	-	500	715	930	-	1695	1795	1895	
600 to 830	505 to 690	345 to 460	-	650	940	-	-	1695	1795	-	
925 to 1300	740 to 965	510 to 640	-	930	-	-	-	1695	-	-	
1400 to 1660	1040 to 1390	705 to 920	650	1230	-	-	1595	1695	-	-	

* normal connection

Battery racks

5. Designations for single and double tier, standard floor mounted racks : single cell range (diagrams 1 to 6)

Cell type			1 tier No. of steps			2 tier No. of steps		
LCE..P	MC..P	HC..P	2	3	4	2	3	4
10 to 62	9 to 55	9 to 34	SGL2	SGL3	SGL4	ESGL2	ESGL3	ESGL4
75 to 220	70 to 185	40 to 120	SGL2	SGL3	SGL4	ESGL2	ESGL3	ESGL4
235 to 375	215 to 335	130 to 210	SGL2	SGL3	SGL4	ESGL2	ESGL3	ESGL4

6. Designations for single and double tier, standard floor mounted racks : extended cell range (diagrams 7 - 10)

Cell type			1 tier No. of steps				2 tier No. of steps			
LBE..P	MB..P	HB..P	1	2	3	4	1	2	3	4
415 to 510*	370 to 390*	-	-	SGL2	SGL3	SGL4	-	ESGL2	ESGL3	ESGL4
550	415 to 460	230 to 305	-	SGL2	SGL3	SGL4	-	ESGL2	ESGL3	ESGL4
600 to 830	505 to 690	345 to 460	-	SGS2	SGS3	-	-	ESGS2	ESGS3	-
925 to 1300	740 to 965	510 to 640	-	SGT2	-	-	-	ESGT2	-	-
1400 to 1660	1040 to 1390	705 to 920	PGS2	SGU2	-	-	EPGS2	ESGU2	-	-

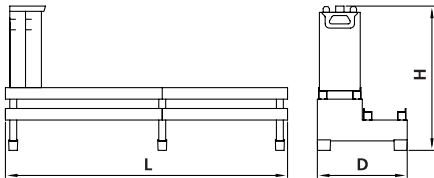

Diagram 1.
1 tier, 2 steps, normal connection

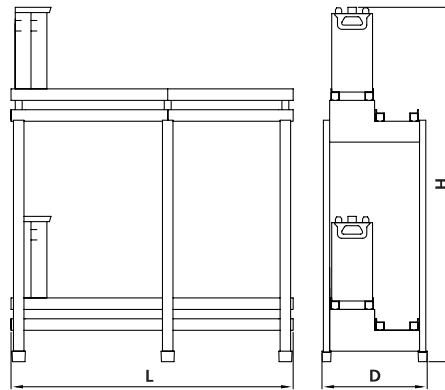

Diagram 2.
2 tier, 2 steps, normal connection

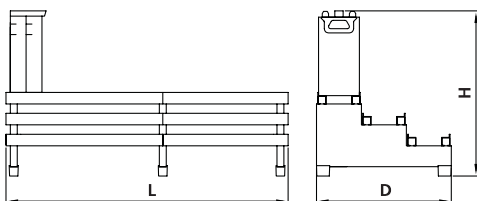

Diagram 3.
1 tier, 3 steps, normal connection

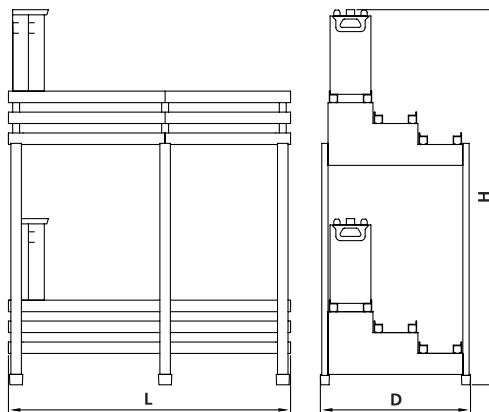

Diagram 4.
2 tier, 3 steps, normal connection

Battery racks

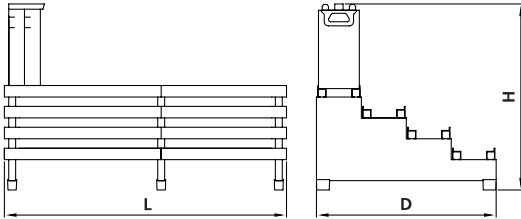

Diagram 5.
1 tier, 4 steps, normal connection

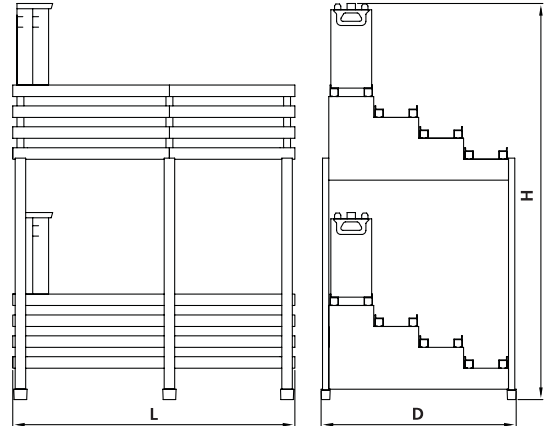

Diagram 6.
2 tier, 4 steps, normal connection

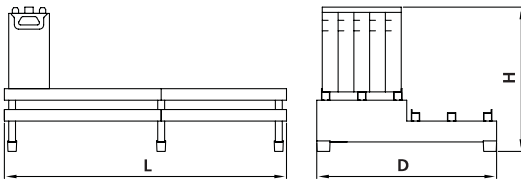

Diagram 7.
1 tier, 2 steps, crosswise connection

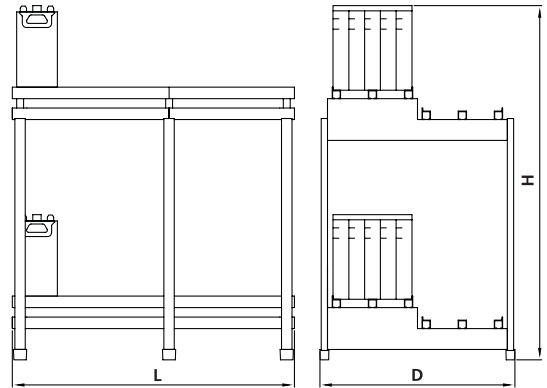

Diagram 8.
2 tier, 2 steps, crosswise connection

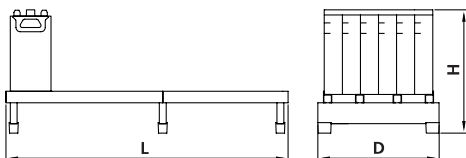

Diagram 9.
1 tier, 1 step, crosswise connection

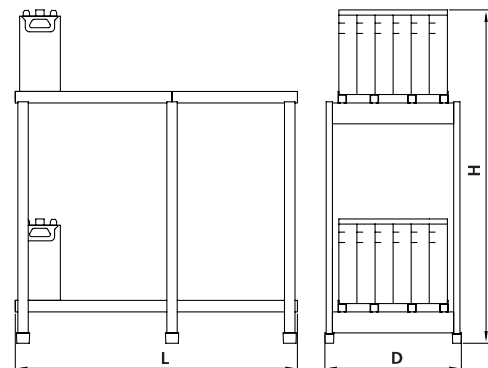

Diagram 10.
2 tier, 1 step, crosswise connection

Disposal and recycling

In a world where autonomous sources of electric power are ever more in demand, Alcad batteries provide an environmentally responsible answer to these needs. Environmental management lies at the core of Alcad's business and we take care to control every stage of a battery's life-cycle in terms of potential impact. Environmental protection is our top priority, from design and production through end-of-life collection, disposal and recycling.

Our respect for the environment is complemented by an equal respect for our customers. We aim to generate confidence in our products, not only from a functional standpoint, but also in terms of the environmental safeguards that are built into their life-cycle. The simple and unique nature of the battery components make them readily recyclable and this process safeguards valuable natural resources for future generations.

In partnership with collection agencies worldwide, Alcad organises retrieval from pre-collection points and the recycling of spent Alcad batteries. Information about Alcad's collection network can be found on our web site :

www.alcad.com

Ni-Cd batteries must not be discarded as harmless waste and should be treated carefully in accordance with local and national regulations. Your Alcad representative can assist with further information on these regulations and with the overall recycling procedure.

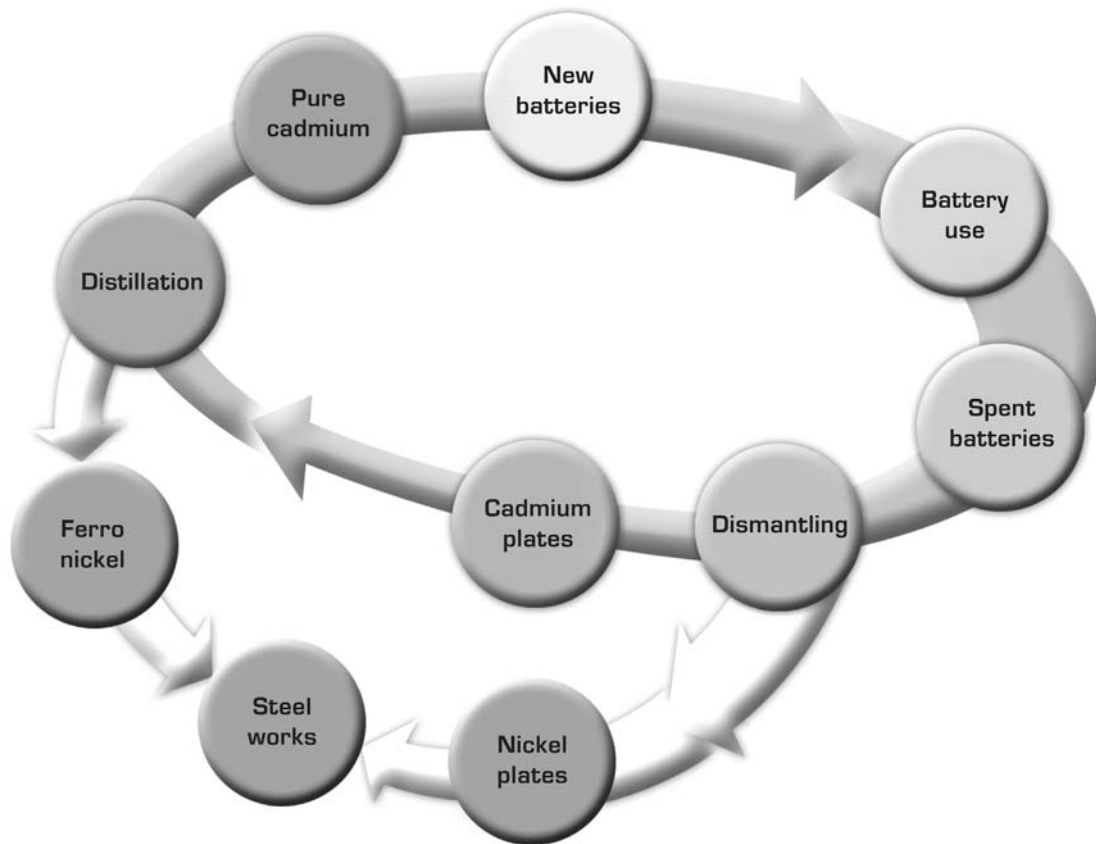

Ni-Cd single cells

LD P - M P ranges

Capacity: 10 Ah to 70 Ah

LDP MP



Nickel-cadmium single cells are designed for general purpose applications, where maximum operating reliability is a key factor:

- switch tripping
- emergency lighting
- alarms
- DC instrumentation

LD P cells are designed for long discharge periods, typically 2 hours and longer.

M P cells are designed for medium discharge periods between 30 minutes and 3 hours.

Benefits

- They provide a long service life, minor maintenance requirements, outstanding resistance to electrical and mechanical abuse, excellent charge retention, a long shelf life and long operation over a wide temperature range.
- Translucent polypropylene containers allow visibility of the electrolyte level, hence facilitating maintenance in stationary applications.
- The junction between the lid and the container is thermo-welded, ensuring good mechanical and electrical resistance.
- Flip top vents assure an easy maintenance.
- The products are qualified according IEC 60 623.

Delivering quality

ALCAD

Mechanical characteristics

Cell type	Capacity C ₅ A (Ah)	Electrolyte reserve		Approx. weight per cell		Height (H)		Dimensions (mm)		Length (L1)		Terminal
		(cc)	(in ³)	kg	lbs.	Width (W)		Length (L1)				
						mm	in	mm	in			
LD 10 P	10	80	4.88	0.9	1.9	177	6.97	122.5	4.83	35.5	1.40	M 6
LD 20 P	20	80	4.88	1.1	2.4	177	6.97	122.5	4.83	35.5	1.40	M 6
LD 30 P	30	165	10.1	1.8	4.0	237	9.34	122.5	4.83	44.5	1.75	M 6
LD 40 P	40	165	10.1	1.9	4.1	237	9.34	122.5	4.83	44.5	1.75	M 6
LD 55 P	55	195	14.0	2.8	6.1	291	11.5	122.5	4.83	54.5	2.15	M 10
LD 70 P	70	195	14.0	3.1	6.8	291	11.5	122.5	4.83	54.5	2.15	M 10
M 11 P	11	115	7.02	1.7	3.7	287	11.3	87	3.43	46	1.81	M 10
M 18 P	18	110	6.71	1.9	4.1	287	11.3	87	3.43	46	1.81	M 10
M 25 P	25	105	6.41	2.0	4.4	287	11.3	87	3.43	46	1.81	M 10
M 32 P	32	230	14.0	3.0	6.6	287	11.3	87	3.43	86	3.39	M 10
M 38 P	38	225	13.7	3.2	7.0	287	11.3	87	3.43	86	3.39	M 10
M 45 P	45	215	13.1	3.4	7.5	287	11.3	87	3.43	86	3.39	M 10
M 55 P	53	210	12.8	3.6	8.0	287	11.3	87	3.43	86	3.39	M 10
M 60 P	59	205	12.5	3.7	8.1	287	11.3	87	3.43	86	3.39	M 10



Alcad is committed to the highest standards of environmental stewardship

Implementing this commitment to minimise the impact of its products and operations on the environment means that Alcad gives priority to recycled over unrecycled raw materials, reduces its plant releases into the environment year after year, minimizes water usage, and ensures that its customers have recycling solutions for their batteries at the end of their lives.

Regarding industrial Ni-Cd batteries, Alcad has had partnerships for many years with collection companies in most EU countries as well as in North

America. This collection network receives and dispatches our customers' batteries at the end of their lives to fully approved recycling facilities, in compliance with the Laws governing transboundary waste shipments. Alcad offers these services free of charge to its customers.

Please find a list of our collection points on our web site.

In other countries, Alcad assists its customers in finding environmentally sound recycling solutions. Please contact your sales representative for further information.

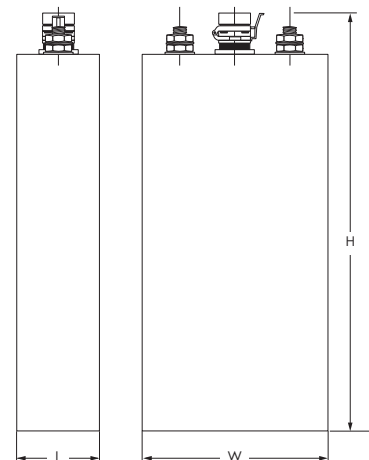

Cell performance L type at +20°C ± 5°C (+68°F ± 41°F)

Available amperes for fully charged cells after constant current charging to IEC 60 623

Final voltage: 1.00 V/cell

Cell type	C ₅ Ah	Hours					Minutes			
		10	8	5	3	2	90	60	45	30
LD 10 P	10	1.13	1.36	2.00	3.03	4.05	4.87	6.10	7.00	8.20
LD 20 P	20	2.26	2.73	4.00	6.07	8.10	9.73	12.2	14.0	16.4
LD 30 P	30	3.27	3.94	6.00	9.50	13.2	16.0	19.8	22.4	25.8
LD 40 P	40	4.36	5.25	8.00	12.7	17.6	21.3	26.4	29.9	34.4
LD 55 P	55	5.83	7.22	11.0	17.8	25.3	30.8	38.5	44.0	50.6
LD 70 P	70	7.42	9.19	14.0	22.6	32.2	39.2	49.0	56.0	64.4

Final voltage: 1.05 V/cell

Cell type	C ₅ Ah	Hours					Minutes			
		10	8	5	3	2	90	60	45	30
LD 10 P	10	1.09	1.33	1.92	2.80	3.60	4.27	5.20	6.00	7.00
LD 20 P	20	2.18	2.65	3.84	5.60	7.20	8.53	10.4	12.0	14.0
LD 30 P	30	3.18	3.90	5.82	8.90	12.0	14.4	18.0	20.0	22.8
LD 40 P	40	4.24	5.20	7.76	11.9	16.0	19.2	24.0	26.7	30.4
LD 55 P	55	5.83	7.15	10.8	17.2	24.2	29.0	35.2	39.6	44.0
LD 70 P	70	7.42	9.10	13.7	21.9	30.8	36.9	44.8	50.4	56.0

Final voltage: 1.10 V/cell

Cell type	C ₅ Ah	Hours					Minutes			
		10	8	5	3	2	90	60	45	30
LD 10 P	10	1.04	1.26	1.82	2.57	3.15	3.60	4.20	4.80	5.60
LD 20 P	20	2.08	2.53	3.64	5.13	6.30	7.20	8.40	9.60	11.2
LD 30 P	30	3.12	3.83	5.70	8.20	10.4	12.0	14.7	16.4	19.2
LD 40 P	40	4.16	5.10	7.60	10.9	13.8	16.0	19.6	21.9	25.6
LD 55 P	55	5.72	7.01	10.6	15.6	20.4	24.2	29.7	33.7	38.5
LD 70 P	70	7.28	8.93	13.4	19.8	25.9	30.8	37.8	42.9	49.0

Final voltage: 1.14 V/cell

Cell type	C ₅ Ah	Hours					Minutes			
		10	8	5	3	2	90	60	45	30
LD 10 P	10	0.97	1.15	1.60	2.20	2.70	3.07	3.60	4.00	4.40
LD 20 P	20	1.94	2.30	3.20	4.40	5.40	6.13	7.20	8.00	8.80
LD 30 P	30	3.00	3.64	5.40	7.50	9.15	10.2	12.0	12.8	14.4
LD 40 P	40	4.00	4.85	7.20	10.0	12.2	13.6	16.0	17.1	19.2
LD 55 P	55	5.61	6.81	10.1	14.1	17.6	19.8	23.1	25.7	29.7
LD 70 P	70	7.14	8.66	12.9	18.0	22.4	25.2	29.4	32.7	37.8

Cell performance M type at +20°C ± 5°C (+68°F ± 41°F)

Available amperes for fully charged cells after constant current charging to IEC 60 623

Final voltage: 1.00 V/cell

Cell type	C ₅ Ah	Hours						Minutes								Seconds		
		10	8	5	3	2	90	60	45	30	20	15	10	5	1	30	5	1
M 11 P	11	1.12	1.39	2.20	3.56	5.12	6.60	9.13	11.3	14.7	18.5	21.1	24.4	29.0	44.0	46.2	59.4	72.6
M 18 P	18	1.83	2.27	3.60	5.82	8.37	10.8	14.9	18.5	24.1	30.2	34.6	40.0	47.5	72.0	75.6	97.2	119
M 25 P	25	2.54	3.15	5.00	8.08	11.6	15.0	20.8	25.7	33.5	42.0	48.0	55.5	66.0	100	105	135	165
M 32 P	32	3.25	4.03	6.40	10.3	14.9	19.2	26.6	32.9	42.9	53.8	61.4	71.0	84.5	128	134	173	211
M 38 P	38	3.86	4.79	7.60	12.3	17.7	22.8	31.5	39.0	50.9	63.8	73.0	84.4	100	152	160	205	251
M 45 P	45	4.57	5.67	9.00	14.6	21.0	27.0	37.3	46.2	60.3	75.6	86.4	99.9	118	180	189	243	297
M 55 P	53	5.38	6.68	10.6	17.1	24.6	31.8	44.0	54.4	71.0	89.0	102	118	140	212	223	286	350
M 60 P	59	5.99	7.43	11.8	19.1	27.4	35.4	49.0	60.6	79.1	99.1	113	131	156	236	248	319	389

Final voltage: 1.05 V/cell

Cell type	C ₅ Ah	Hours						Minutes								Seconds		
		10	8	5	3	2	90	60	45	30	20	15	10	5	1	30	5	1
M 11 P	11	1.11	1.38	2.18	3.52	5.06	6.38	8.80	10.7	13.4	16.2	18.0	20.5	25.1	36.3	40.7	51.7	62.7
M 18 P	18	1.81	2.25	3.56	5.76	8.28	10.4	14.4	17.5	22.0	26.5	29.5	33.5	41.0	59.4	66.6	84.6	103
M 25 P	25	2.52	3.13	4.95	8.00	11.5	14.5	20.0	24.3	30.5	36.8	41.0	46.5	57.0	82.5	92.5	118	143
M 32 P	32	3.22	4.00	6.34	10.2	14.7	18.6	25.6	31.1	39.0	47.0	52.5	59.5	73.0	106	118	150	182
M 38 P	38	3.83	4.75	7.52	12.2	17.5	22.0	30.4	37.0	46.4	55.9	62.3	70.7	86.6	125	141	179	217
M 45 P	45	4.54	5.63	8.91	14.4	20.7	26.1	36.0	43.8	54.9	66.2	73.8	83.7	103	148	167	212	257
M 55 P	53	5.34	6.63	10.5	17.0	24.4	30.7	42.4	51.6	64.7	77.9	86.9	98.6	121	175	196	249	302
M 60 P	59	5.94	7.38	11.7	18.9	27.1	34.2	47.2	57.4	72.0	86.7	96.8	110	135	195	218	277	336

Final voltage: 1.10 V/cell

Cell type	C ₅ Ah	Hours						Minutes								Seconds		
		10	8	5	3	2	90	60	45	30	20	15	10	5	1	30	5	1
M 11 P	11	1.09	1.35	2.13	3.41	4.84	6.01	7.81	9.09	11.4	13.5	15.0	17.2	19.8	30.8	34.1	44.0	52.8
M 18 P	18	1.78	2.21	3.49	5.58	7.92	9.84	12.8	14.9	18.7	22.1	24.5	28.1	32.4	50.4	55.8	72.0	86.4
M 25 P	25	2.48	3.08	4.85	7.75	11.0	13.7	17.8	20.7	26.0	30.8	34.0	39.0	45.0	70.0	77.5	100	120
M 32 P	32	3.17	3.94	6.21	9.92	14.1	17.5	22.7	26.5	33.3	39.4	43.5	49.9	57.6	89.6	99.2	128	154
M 38 P	38	3.77	4.67	7.37	11.8	16.7	20.8	27.0	31.4	39.5	46.7	51.7	59.3	68.4	106	118	152	182
M 45 P	45	4.46	5.53	8.73	14.0	19.8	24.6	32.0	37.2	46.8	55.3	61.2	70.2	81.0	126	140	180	216
M 55 P	53	5.25	6.52	10.3	16.4	23.3	29.0	37.6	43.8	55.1	65.2	72.1	82.7	95.4	148	164	212	254
M 60 P	59	5.85	7.26	11.4	18.3	26.0	32.3	41.9	48.8	61.4	72.6	80.2	92.0	106	165	183	236	283

Final voltage: 1.14 V/cell

Cell type	C ₅ Ah	Hours						Minutes								Seconds		
		10	8	5	3	2	90	60	45	30	20	15	10	5	1	30	5	1
M 11 P	11	1.06	1.32	2.07	3.23	4.40	5.35	6.71	7.63	9.02	10.6	11.9	13.9	17.2	26.4	29.7	37.4	46.2
M 18 P	18	1.74	2.16	3.38	5.28	7.20	8.76	11.0	12.5	14.8	17.3	19.4	22.7	28.1	43.2	48.6	61.2	75.6
M 25 P	25	2.42	3.00	4.70	7.33	10.0	12.2	15.3	17.3	20.5	24.0	27.0	31.5	39.0	60.0	67.5	85.0	105
M 32 P	32	3.09	3.84	6.02	9.39	12.8	15.6	19.5	22.2	26.2	30.7	34.6	40.3	49.9	76.8	86.4	109	134
M 38 P	38	3.67	4.56	7.14	11.2	15.2	18.5	23.2	26.4	31.2	36.5	41.0	47.9	59.3	91.2	103	129	160
M 45 P	45	4.35	5.40	8.46	13.2	18.0	21.9	27.5	31.2	36.9	43.2	48.6	56.7	70.2	108	122	153	189
M 55 P	53	5.13	6.36	9.96	15.6	21.2	25.8	32.3	36.8	43.5	50.9	57.2	66.8	82.7	127	143	180	223
M 60 P	59	5.71	7.08	11.1	17.3	23.6	28.7	36.0	40.9	48.4	56.6	63.7	74.3	92.0	142	159	201	248

Cell performance L type at +20°C ± 5°C (+68°F ± 41°F)

Available amperes after long term floating with constant voltage charging

Final voltage: 1.00 V/cell

Cell type	C ₅ Ah	Hours					Minutes			
		10	8	5	3	2	90	60	45	30
LD 10 P	10	1.13	1.36	2.00	3.03	3.85	4.38	5.31	5.95	6.81
LD 20 P	20	2.26	2.73	4.00	6.07	7.70	8.76	10.6	11.9	13.6
LD 30 P	30	3.27	3.94	6.00	9.50	12.5	14.4	17.2	19.0	21.4
LD 40 P	40	4.36	5.25	8.00	12.7	16.7	19.2	23.0	25.4	28.6
LD 55 P	55	5.83	7.22	11.0	17.8	24.0	27.7	33.5	37.4	42.0
LD 70 P	70	7.42	9.19	14.0	22.6	30.6	35.3	42.6	47.6	53.5

Final voltage: 1.05 V/cell

Cell type	C ₅ Ah	Hours					Minutes			
		10	8	5	3	2	90	60	45	30
LD 10 P	10	1.09	1.33	1.92	2.55	3.10	3.58	4.21	4.77	5.46
LD 20 P	20	2.18	2.65	3.84	5.10	6.19	7.17	8.42	9.54	10.9
LD 30 P	30	3.18	3.90	5.82	8.10	10.3	12.1	14.6	15.9	17.8
LD 40 P	40	4.24	5.20	7.76	10.8	13.8	16.1	19.4	21.2	23.7
LD 55 P	55	5.83	7.15	10.8	15.7	20.8	24.3	28.5	31.5	34.3
LD 70 P	70	7.42	9.10	13.7	20.0	26.5	31.0	36.3	40.1	43.7

Final voltage: 1.10 V/cell

Cell type	C ₅ Ah	Hours					Minutes			
		10	8	5	3	2	90	60	45	30
LD 10 P	10	1.04	1.22	1.64	2.13	2.52	2.81	3.19	3.58	4.09
LD 20 P	20	2.08	2.45	3.28	4.26	5.04	5.62	6.38	7.15	8.18
LD 30 P	30	3.12	3.71	5.13	6.81	8.28	9.36	11.2	12.2	14.0
LD 40 P	40	4.16	4.95	6.84	9.07	11.0	12.5	14.9	16.3	18.7
LD 55 P	55	5.72	6.80	9.50	12.9	16.3	18.9	22.6	25.1	28.1
LD 70 P	70	7.28	8.66	12.1	16.5	20.7	24.0	28.7	32.0	35.8

Final voltage: 1.14 V/cell

Cell type	C ₅ Ah	Hours					Minutes			
		10	8	5	3	2	90	60	45	30
LD 10 P	10	0.97	1.09	1.30	1.67	2.00	2.24	2.56	2.78	2.99
LD 20 P	20	1.94	2.19	2.59	3.34	4.00	4.48	5.11	5.56	5.98
LD 30 P	30	3.00	3.46	4.37	5.70	6.77	7.45	8.52	8.90	9.79
LD 40 P	40	4.00	4.61	5.83	7.60	9.03	9.93	11.4	11.9	13.1
LD 55 P	55	5.61	6.47	8.20	10.7	13.0	14.5	16.4	17.8	20.2
LD 70 P	70	7.14	8.23	10.4	13.7	16.6	18.4	20.9	22.7	25.7

Cell performance M type at +20°C ± 5°C (+68°F ± 41°F)

Available amperes after long term floating with constant voltage charging

Final voltage: 1.00 V/cell

Cell type	C ₅ Ah	Hours					Minutes									Seconds		
		10	8	5	3	2	90	60	45	30	20	15	10	5	1	30	5	1
M 11 P	11	1.12	1.39	2.20	3.56	5.12	6.14	7.94	9.54	12.1	15.2	17.1	19.5	23.2	35.2	37.0	47.5	58.1
M 18 P	18	1.83	2.27	3.60	5.82	8.37	10.0	13.0	15.6	19.8	24.8	28.0	32.0	38.0	57.6	60.5	77.8	95.0
M 25 P	25	2.54	3.15	5.00	8.08	11.6	14.0	18.1	21.7	27.5	34.4	38.9	44.4	52.8	80.0	84.0	108	132
M 32 P	32	3.25	4.03	6.40	10.3	14.9	17.9	23.1	27.8	35.2	44.1	49.8	56.8	67.6	102	108	138	169
M 38 P	38	3.86	4.79	7.60	12.3	17.7	21.2	27.4	33.0	41.8	52.3	59.1	67.5	80.3	1	128	164	201
M 45 P	45	4.57	5.67	9.00	14.6	21.0	25.1	32.4	39.1	49.5	61.9	70.0	79.9	95.1	144	152	194	238
M 55 P	53	5.38	6.68	10.6	17.1	24.6	29.6	38.3	46.0	58.2	73.0	82.4	94.1	112	170	178	229	280
M 60 P	59	5.99	7.43	11.8	19.1	27.4	32.9	42.6	51.2	64.8	81.3	91.8	105.00	125	189	198	255	312

Final voltage: 1.05 V/cell

Cell type	C ₅ Ah	Hours					Minutes									Seconds		
		10	8	5	3	2	90	60	45	30	20	15	10	5	1	30	5	1
M 11 P	11	1.11	1.38	2.18	3.52	4.55	5.42	7.22	8.57	10.5	12.3	13.7	15.5	18.8	27.2	30.5	38.8	47.0
M 18 P	18	1.81	2.25	3.56	5.76	7.45	8.87	11.8	14.0	17.1	20.1	22.4	25.4	30.8	44.6	50.0	63.5	77.0
M 25 P	25	2.52	3.13	4.95	8.00	10.4	12.3	16.4	19.5	23.8	27.9	31.2	35.3	42.8	61.9	69.4	88.1	107
M 32 P	32	3.22	4.00	6.34	10.2	13.2	15.8	21.0	24.9	30.5	35.8	39.9	45.2	54.7	79.2	88.8	113	137
M 38 P	38	3.83	4.75	7.52	12.2	15.7	18.7	24.9	29.6	36.2	42.5	47.4	53.7	65.0	94.1	105	134	162
M 45 P	45	4.54	5.63	8.91	14.4	18.6	22.1	29.5	35.1	42.9	50.3	56.1	63.6	77.0	111	124	159	192
M 55 P	53	5.34	6.63	10.5	17.0	21.9	26.1	34.8	41.3	50.4	59.2	66.1	74.9	90.6	131	147	187	227
M 60 P	59	5.94	7.38	11.7	18.9	24.4	29.1	38.7	45.9	56.1	65.9	73.5	83.4	101	146	164	208	252

Final voltage: 1.10 V/cell

Cell type	C ₅ Ah	Hours					Minutes									Seconds		
		10	8	5	3	2	90	60	45	30	20	15	10	5	1	30	5	1
M 11 P	11	1.09	1.35	2.13	3.17	4.07	4.81	6.01	6.87	8.47	9.88	10.8	12.2	14.1	21.9	24.2	31.2	37.5
M 18 P	18	1.78	2.21	3.49	5.19	6.65	7.87	9.84	11.2	13.9	16.2	17.6	19.9	23.0	35.8	39.6	51.1	61.3
M 25 P	25	2.48	3.08	4.85	7.21	9.24	10.9	13.7	15.6	19.2	22.4	24.5	27.7	32.0	49.7	55.0	71.0	85.2
M 32 P	32	3.17	3.94	6.21	9.23	11.8	14.0	17.5	20.0	24.6	28.7	31.3	35.4	40.9	63.6	70.4	90.9	109
M 38 P	38	3.77	4.67	7.37	11.0	14.0	16.6	20.8	23.7	29.2	34.1	37.2	42.1	48.6	75.5	83.6	108	130
M 45 P	45	4.46	5.53	8.73	13.0	16.6	19.7	24.6	28.1	34.6	40.4	44.1	49.9	57.6	89.4	99.0	128	154
M 55 P	53	5.25	6.52	10.3	15.3	19.6	23.2	29.0	33.1	40.8	47.6	51.9	58.7	67.7	105	117	151	181
M 60 P	59	5.85	7.26	11.4	17.0	21.8	25.8	32.3	36.8	45.4	53.0	57.8	65.3	75.4	117	130	168	201

Final voltage: 1.14 V/cell

Cell type	C ₅ Ah	Hours					Minutes									Seconds		
		10	8	5	3	2	90	60	45	30	20	15	10	5	1	30	5	1
M 11 P	11	1.06	1.32	2.07	2.74	3.39	4.02	4.83	5.38	6.22	7.18	7.96	9.29	11.5	17.7	19.9	25.1	31.0
M 18 P	18	1.74	2.16	3.38	4.49	5.54	6.57	7.91	8.80	10.2	11.8	13.0	15.2	18.8	28.9	32.6	41.0	50.7
M 25 P	25	2.42	3.00	4.70	6.23	7.70	9.13	11.0	12.2	14.1	16.3	18.1	21.1	26.1	40.2	45.2	57.0	70.4
M 32 P	32	3.09	3.84	6.02	7.98	9.86	11.7	14.1	15.6	18.1	20.9	23.2	27.0	33.4	51.5	57.9	72.9	90.0
M 38 P	38	3.67	4.56	7.14	9.47	11.7	13.9	16.7	18.6	21.5	24.8	27.5	32.1	39.7	61.1	68.7	86.6	107
M 45 P	45	4.35	5.40	8.46	11.2	13.9	16.5	19.8	22.0	25.5	29.4	32.6	38.0	47.0	72.4	81.4	103	127
M 55 P	53	5.13	6.36	9.96	13.2	16.3	19.3	23.3	25.9	30.0	34.6	38.4	44.7	55.4	85.2	95.9	121	149
M 60 P	59	5.71	7.08	11.1	14.7	18.2	21.5	25.9	28.8	33.4	38.5	42.7	49.8	61.7	94.9	107	134	166

Alcad Limited

Sweden

Telephone: +46 491 68 100

Facsimile: +46 491 68 110

Alcad Sales offices

United Kingdom

Telephone: +44 1279 772 555

Facsimile: +44 1279 420 696

Cyprus

Telephone: +357 25 871 816

Facsimile: +357 25 343 542

Singapore

Telephone: +65 6 7484 486

Facsimile: +65 6 7484 639

USA

Telephone: +1 203 234 8333

Facsimile: +1 203 234 8255

Edition March 2006 - L2.4 - 0306 - Pragma

Data in this document are subject to change without any notice and become contractual only after written confirmation by Alcad.

Delivering quality

ALCAD



Vantex

Low maintenance Ni-Cd batteries

Delivering quality

ALCAD



Vantex Range

Low maintenance Ni-Cd batteries for high temperature operation

In off-shore oil and gas applications, utilities, switching sub-stations and in other remote locations, gaining access for battery maintenance can be difficult, hazardous and expensive. Battery operation that is simple, with reliable performance, long life and minimum maintenance is vital.

Vantex is the solution – an innovation in the design and manufacture of advanced, high technology batteries for operation particularly in high temperature conditions.

Vantex is new

Alcad has more than 100 years experience in the design and manufacture of batteries to meet particular industrial needs. The ground-breaking Vantex concept provides exceptionally reliable performance, even at very high operating temperatures, but requires the minimum of maintenance.

Its well-proven, robust Ni-Cd pocket plate construction and low maintenance concept provide a battery of superior capability. This profile suits particularly installations where access is restricted and where maintenance visits must be minimised.

Vantex is offered in a very wide capacity range, from 8 Ah to 1700 Ah, and with a choice of two plate types.

L RANGE – suitable for low discharge times of between 3 and 100 hours,

M RANGE – designed to manage mixed loads of high and low discharge rates for between 30 minutes and 3 hours.

Long life at high temperatures

Vantex shows good endurance with excellent results, with both cell types exceeding **by more than 4 times the endurance test of IEC 62259**.

The battery performs reliably at temperatures of up to +40°C (+104°F), and in extreme conditions to -40°C and +70°C (-40°F and +158°F). Vantex has a service life expectancy of **12 plus years** at +40°C (+104°F) and of **20 plus years** at +20°C (+68°F). It can never suffer from 'sudden death' owing to the total reliability of Ni-Cd electrochemistry.

Additionally, M type cells achieve more than **90% capacity even at +40°C (+104°F)** after a constant charge at 1.43 V/cell for 15 hours with a charge current of 0.1C₅ A. Excellent chargeability at low charge voltage reduces downtime load voltage window and ensures the battery returns quickly to duty, maintaining application reliability.

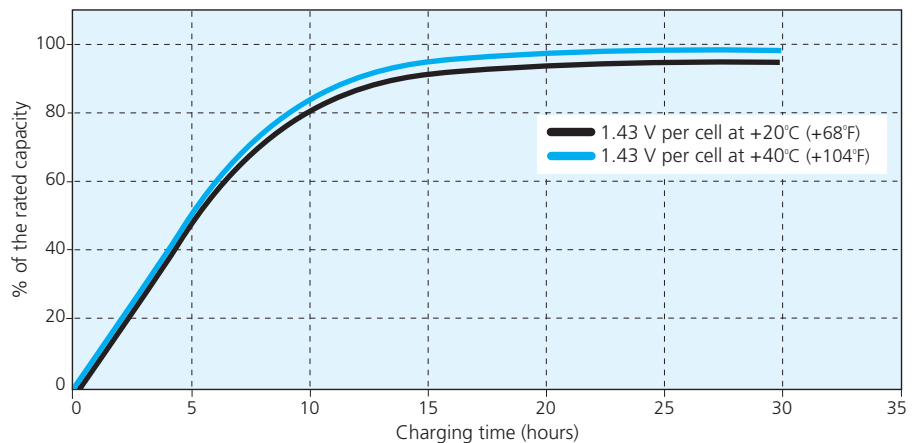

Cell type: VTX1 M
Available capacity after constant voltage charge.
Available charge current 0.1C₅ A.



Easy to handle

The optimised design of Vantex includes several features to make transportation, installation and operation fast and easy.

Up to six cells are configured in series and assembled in blocks to enable easy handling. As Vantex cells are always factory-filled with electrolyte, rapid installation on site means the battery and application can be brought quickly into operation, minimizing downtime.

Long storage periods

When filled, Vantex may be stored for up to 2 years in normal conditions without affecting future performance.

Only one top-up during life

The Vantex design enables highly efficient gas recombination of more than 90% – far beyond the requirements of IEC 62259 – allowing very low gas emissions and water consumption. As a result, Vantex may require only one topping-up operation during its entire service life.

Contents

Charging	4
Quality standards	4
Battery layout	5
Recycling	5
Physical properties	
L Range	6
M Range	7
Electrical performance	
L Range	8–11
M Range	12–15

Very rapid charging

Charging of Vantex may be carried out with either single or two level methods.

Single level low voltage charging without temperature compensation* enables Vantex to be charged and discharged within a low load voltage window.

* except for low temperatures

For single level charge

1.43 ± 0.01 V/cell

For two level charge

float level: 1.43 ± 0.01 V/cell

high level: 1.45 ± 0.01 V/cell

Built and tested to quality standards

Vantex is manufactured to the highest international quality standards in production facilities qualified to ISO 9001 and ISO 14001.

The design complies with IEC 62259 and far exceeds the requirement for a minimum 70% gas recombination level.

And Vantex is safe, in line with the requirements of EN 50272-2. Components such as insulated cable connectors and end lug covers meet IP2 level to ensure protection against electric shocks.

Quality support, too

A comprehensive service, technical and training backup is provided by Alcad's global sales and after-sales support network.

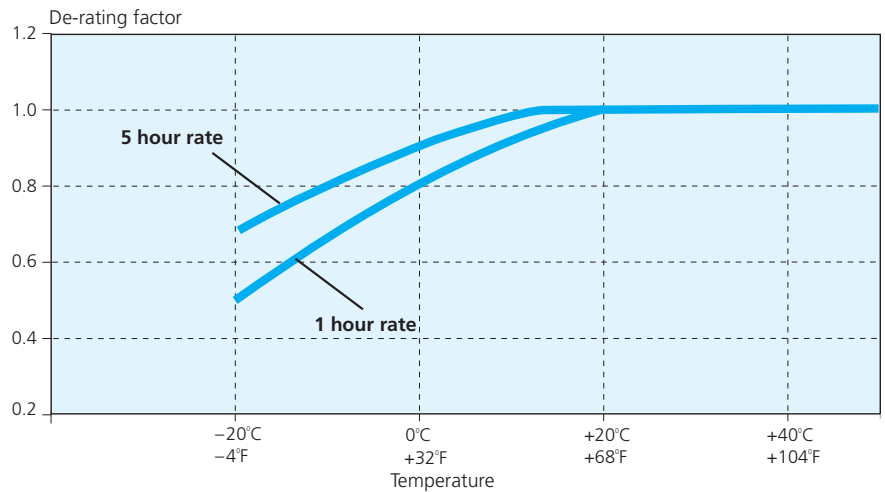

Temperature de-rating factors for L type cells

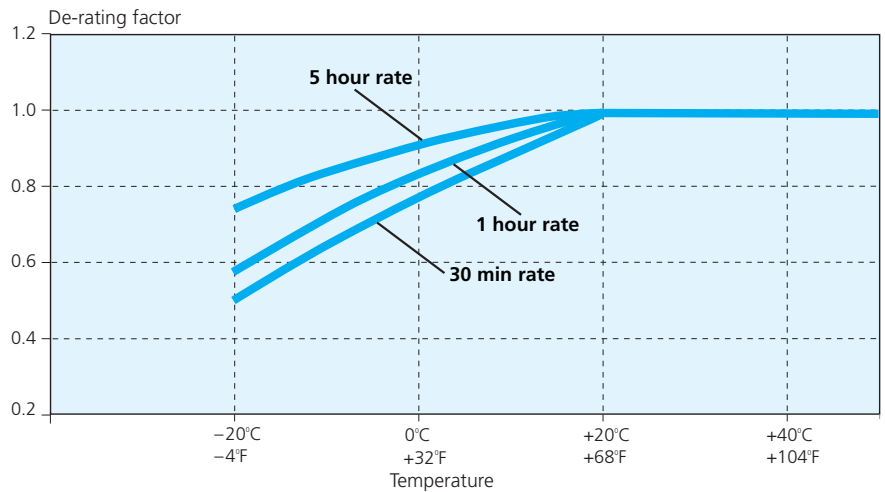

Temperature de-rating factors for M type cells

Block configuration

For serial connection of blocks on racks or on shelves, always use blocks with an even number of cells. This gives short, straight interblock connectors. When a block with an odd number of cells is necessary, it should be placed at the end of a cell row.

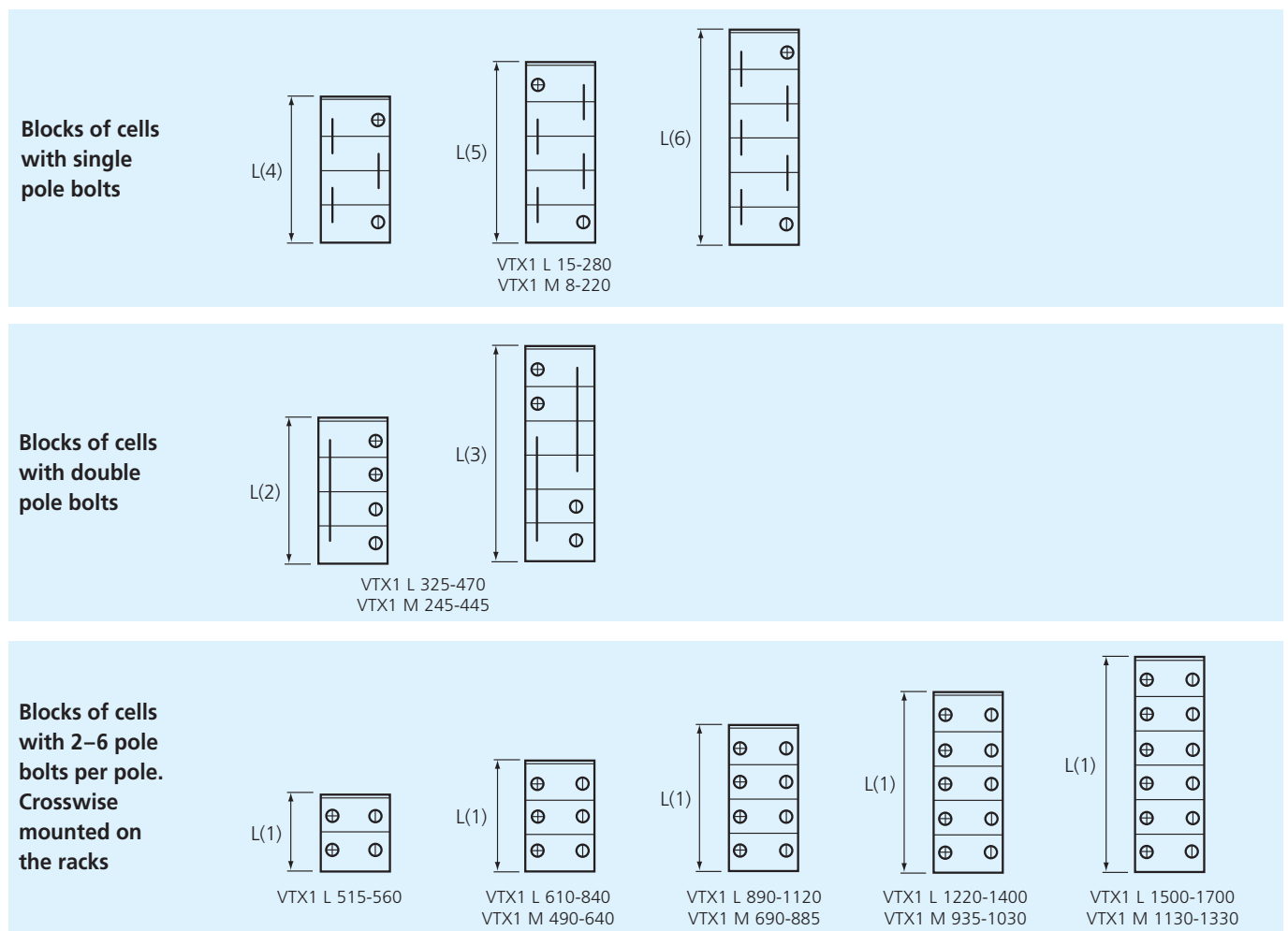

Disposal and recycling

Ni-Cd batteries provide an environmentally responsible solution to growing demands for autonomous electric power. Alcad prioritise environmental care through control at every stage of a battery's life – from design and production to end-of-life collection, disposal and recycling. The simple and unique nature of components make Alcad batteries readily recyclable and this process safeguards valuable natural resources. Alcad works in partnership with collection agencies worldwide to retrieve from pre-collection points and recycle spent Alcad batteries. Visit our web site for further details: www.alcad.com

Ni-Cd batteries should be treated carefully in accordance with local and national regulations and must not be discarded as harmless waste. Alcad representatives can assist with further information on these regulations and with the overall recycling procedure.

L Range

Cell dimensions and internal resistance

Vantex type	Capacity C ₅ Ah	Height		Width		Length per block												Approx. weight per cell		Internal resistance* mOhm	Cell connection bolt per pole		
		mm	in	mm	in	1 cell		2 cells		3 cells		4 cells		5 cells		6 cells		kg	lb				
						mm	in	mm	in	mm	in	mm	in	mm	in	mm	in	mm	in				
VTX1 L 15	15	270	10.6	123	4.8	-	-	-	-	-	-	101	3.97	124	4.88	148	5.82	1.10	2.42			12.1	M6
VTX1 L 30	30	270	10.6	123	4.8	-	-	-	-	-	-	143	5.62	177	6.96	211	8.30	1.80	3.96			6.03	M6
VTX1 L 47	47	270	10.6	123	4.8	-	-	-	-	-	-	191	7.51	237	9.33	283	11.1	2.50	5.51			3.85	M6
VTX1 L 62	62	270	10.6	123	4.8	-	-	-	-	-	-	239	9.40	297	11.6	355	13.9	3.20	7.05			2.92	M6
VTX1 L 75	75	270	10.6	123	4.8	-	-	-	-	-	-	329	12.9	409	16.1	490	19.2	4.30	9.47			2.41	2 x M6
VTX1 L 95	95	421	16.6	195	7.7	-	-	-	-	-	-	156	6.14	192	7.55	228	8.97	4.90	10.8			2.55	M8
VTX1 L 110	110	270	10.6	123	4.8	-	-	-	-	-	-	425	16.7	529	20.8	634	24.9	5.70	12.5			1.65	2 x M6
VTX1 L 140	140	421	16.6	195	7.7	-	-	-	-	-	-	204	8.03	252	9.92	300	11.8	6.70	14.7			1.73	M10
VTX1 L 185	185	421	16.6	195	7.7	-	-	-	-	-	-	252	9.92	312	12.2	372	14.6	8.40	18.5			1.31	M10
VTX1 L 235	235	421	16.6	195	7.7	-	-	-	-	-	-	304	11.9	377	14.8	450	17.7	9.90	21.8			1.03	M10
VTX1 L 280	280	421	16.6	195	7.7	-	-	-	-	-	-	352	13.8	437	17.2	522	20.5	11.5	25.3			0.86	M10
VTX1 L 325	325	421	16.6	195	7.7	-	-	228	8.97	336	13.2	-	-	-	-	-	-	15.1	33.2			0.74	2 x M10
VTX1 L 375	375	421	16.6	195	7.7	-	-	252	9.92	372	14.6	-	-	-	-	-	-	168	37.0			0.65	2 x M10
VTX1 L 420	420	421	16.6	195	7.7	-	-	278	10.9	411	16.1	-	-	-	-	-	-	18.3	40.3			0.58	2 x M10
VTX1 L 470	470	421	16.6	195	7.7	-	-	304	11.9	450	17.7	-	-	-	-	-	-	19.8	43.6			0.51	2 x M10
VTX1 L 515	515	405	15.9	195	7.7	171	6.73	-	-	-	-	-	-	-	-	-	-	21.4	47.1			0.47	2 x M10
VTX1 L 560	560	405	15.9	195	7.7	183	7.20	-	-	-	-	-	-	-	-	-	-	23.0	50.7			0.43	2 x M10
VTX1 L 610	610	405	15.9	195	7.7	207	8.14	-	-	-	-	-	-	-	-	-	-	26.5	58.4			0.40	3 x M10
VTX1 L 650	650	405	15.9	195	7.7	219	8.62	-	-	-	-	-	-	-	-	-	-	28.2	62.1			0.37	3 x M10
VTX1 L 700	700	405	15.9	195	7.7	232	9.13	-	-	-	-	-	-	-	-	-	-	29.7	65.4			0.35	3 x M10
VTX1 L 750	750	405	15.9	195	7.7	243	9.56	-	-	-	-	-	-	-	-	-	-	31.4	69.2			0.32	3 x M10
VTX1 L 800	800	405	15.9	195	7.7	256	10.0	-	-	-	-	-	-	-	-	-	-	32.9	72.5			0.30	3 x M10
VTX1 L 840	840	405	15.9	195	7.7	268	10.5	-	-	-	-	-	-	-	-	-	-	34.5	76.0			0.29	3 x M10
VTX1 L 890	890	405	15.9	195	7.7	291	11.4	-	-	-	-	-	-	-	-	-	-	38.1	83.9			0.27	4 x M10
VTX1 L 940	940	405	15.9	195	7.7	304	11.9	-	-	-	-	-	-	-	-	-	-	39.6	87.3			0.26	4 x M10
VTX1 L 980	980	405	15.9	195	7.7	315	12.4	-	-	-	-	-	-	-	-	-	-	41.2	90.8			0.25	4 x M10
VTX1 L 1030	1030	405	15.9	195	7.7	327	12.8	-	-	-	-	-	-	-	-	-	-	42.9	94.5			0.23	4 x M10
VTX1 L 1120	1120	405	15.9	195	7.7	352	13.8	-	-	-	-	-	-	-	-	-	-	46.0	101.4			0.22	4 x M10
VTX1 L 1220	1220	405	15.9	195	7.7	387	15.2	-	-	-	-	-	-	-	-	-	-	51.3	113.0			0.20	5 x M10
VTX1 L 1300	1300	405	15.9	195	7.7	412	16.2	-	-	-	-	-	-	-	-	-	-	54.4	119.9			0.19	5 x M10
VTX1 L 1400	1400	405	15.9	195	7.7	437	17.2	-	-	-	-	-	-	-	-	-	-	57.5	126.7			0.17	5 x M10
VTX1 L 1500	1500	405	15.9	195	7.7	472	18.5	-	-	-	-	-	-	-	-	-	-	62.8	138.4			0.16	6 x M10
VTX1 L 1600	1600	405	15.9	195	7.7	497	19.5	-	-	-	-	-	-	-	-	-	-	65.9	145.2			0.15	6 x M10
VTX1 L 1700	1700	405	15.9	195	7.7	522	20.5	-	-	-	-	-	-	-	-	-	-	69.0	152.1			0.14	6 x M10

The block length and weight are determined by the number of cells in the block.
All tabulated dimensions are maximum values.

* rigid connector included.

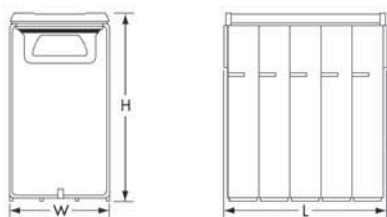

Cell dimensions and internal resistance

M Range

Vantex type	Capacity C ₅ Ah	Height		Width		Length per block												Approx. weight per cell		Internal resistance*	Cell connection bolt per pole
		mm	in	mm	in	1 cell		2 cells		3 cells		4 cells		5 cells		6 cells		kg	lb		
						mm	in	mm	in	mm	in	mm	in	mm	in	mm	in				
VTX1 M 8	8	270	10.6	123	4.8	-	-	-	-	-	-	101	3.97	124	4.88	148	5.82	1.10	2.42	12.5	M6
VTX1 M 16	16	270	10.6	123	4.8	-	-	-	-	-	-	123	4.84	151.5	5.96	181	7.12	1.50	3.30	6.25	M6
VTX1 M 24	24	270	10.6	123	4.8	-	-	-	-	-	-	143	5.62	176.5	6.94	211	8.30	1.80	3.96	4.17	M6
VTX1 M 32	32	270	10.6	123	4.8	-	-	-	-	-	-	191	7.51	236.5	9.31	283	11.1	2.50	5.51	3.13	M6
VTX1 M 40	40	270	10.6	123	4.8	-	-	-	-	-	-	239	9.40	296.5	11.6	355	13.9	3.20	7.05	2.50	M6
VTX1 M 48	48	270	10.6	123	4.8	-	-	-	-	-	-	239	9.40	296.5	11.6	355	13.9	3.30	7.27	2.08	M6
VTX1 M 65	65	270	10.6	123	4.8	-	-	-	-	-	-	377	14.8	469	18.4	562	22.1	5.00	11.0	1.54	2 x M6
VTX1 M 75	75	421	16.6	195	7.7	-	-	-	-	-	-	156	6.14	192	7.55	228	8.97	4.90	10.8	1.52	M8
VTX1 M 100	100	421	16.6	195	7.7	-	-	-	-	-	-	186	7.32	229.5	9.03	273	10.7	6.30	13.8	1.14	M10
VTX1 M 125	125	421	16.6	195	7.7	-	-	-	-	-	-	228	8.97	282	11.1	336	13.2	7.60	16.7	0.91	M10
VTX1 M 150	150	421	16.6	195	7.7	-	-	-	-	-	-	252	9.92	312	12.2	372	14.6	8.40	18.5	0.76	M10
VTX1 M 170	170	421	16.6	195	7.7	-	-	-	-	-	-	304	11.9	377	14.8	450	17.7	9.90	21.8	0.67	M10
VTX1 M 195	195	421	16.6	195	7.7	-	-	-	-	-	-	352	13.8	437	17.2	522	20.5	11.5	25.3	0.58	M10
VTX1 M 220	220	421	16.6	195	7.7	-	-	-	-	-	-	352	13.8	437	17.2	522	20.5	12.0	26.4	0.52	M10
VTX1 M 245	245	421	16.6	195	7.7	-	-	228	8.97	336	13.2	-	-	-	-	-	15.2	33.5	0.47	2 x M10	
VTX1 M 270	270	421	16.6	195	7.7	-	-	240	9.44	354	13.9	-	-	-	-	-	16.0	35.2	0.42	2 x M10	
VTX1 M 295	295	421	16.6	195	7.7	-	-	252	9.92	372	14.6	-	-	-	-	-	16.8	37.0	0.39	2 x M10	
VTX1 M 320	320	421	16.6	195	7.7	-	-	278	10.9	411	16.1	-	-	-	-	-	18.3	40.3	0.36	2 x M10	
VTX1 M 345	345	421	16.6	195	7.7	-	-	304	12.9	450	17.7	-	-	-	-	-	19.8	43.6	0.33	2 x M10	
VTX1 M 370	370	421	16.6	195	7.7	-	-	328	12.9	486	19.1	-	-	-	-	-	21.4	47.1	0.31	2 x M10	
VTX1 M 395	395	421	16.6	195	7.7	-	-	352	13.8	522	20.5	-	-	-	-	-	23.0	50.7	0.29	2 x M10	
VTX1 M 420	420	421	16.6	195	7.7	-	-	352	13.8	522	20.5	-	-	-	-	-	23.5	51.8	0.27	2 x M10	
VTX1 M 445	445	421	16.6	195	7.7	-	-	352	13.8	522	20.5	-	-	-	-	-	24.0	52.9	0.26	2 x M10	
VTX1 M 490	490	405	15.9	195	7.7	219	8.62	-	-	-	-	-	-	-	-	-	28.2	62.1	0.23	3 x M10	
VTX1 M 540	540	405	15.9	195	7.7	243	9.56	-	-	-	-	-	-	-	-	-	31.4	69.2	0.21	3 x M10	
VTX1 M 590	590	405	15.9	195	7.7	268	10.5	-	-	-	-	-	-	-	-	-	34.5	76.0	0.19	3 x M10	
VTX1 M 640	640	405	15.9	195	7.7	268	10.5	-	-	-	-	-	-	-	-	-	35.5	78.2	0.18	3 x M10	
VTX1 M 690	690	405	15.9	195	7.7	304	11.9	-	-	-	-	-	-	-	-	-	39.6	87.3	0.17	4 x M10	
VTX1 M 740	740	405	15.9	195	7.7	327	12.8	-	-	-	-	-	-	-	-	-	42.9	94.5	0.15	4 x M10	
VTX1 M 785	785	405	15.9	195	7.7	352	13.8	-	-	-	-	-	-	-	-	-	46.0	101.4	0.15	4 x M10	
VTX1 M 835	835	405	15.9	195	7.7	340	13.3	-	-	-	-	-	-	-	-	-	45.9	101.1	0.14	4 x M10	
VTX1 M 885	885	405	15.9	195	7.7	352	13.8	-	-	-	-	-	-	-	-	-	48.0	105.8	0.13	4 x M10	
VTX1 M 935	935	405	15.9	195	7.7	412	16.2	-	-	-	-	-	-	-	-	-	54.4	119.9	0.12	5 x M10	
VTX1 M 985	985	405	15.9	195	7.7	437	17.2	-	-	-	-	-	-	-	-	-	57.5	126.7	0.12	5 x M10	
VTX1 M 1030	1030	405	15.9	195	7.7	412	16.2	-	-	-	-	-	-	-	-	-	56.4	124.3	0.11	5 x M10	
VTX1 M 1130	1130	405	15.9	195	7.7	497	19.5	-	-	-	-	-	-	-	-	-	65.9	145.2	0.10	6 x M10	
VTX1 M 1230	1230	405	15.9	195	7.7	491	19.3	-	-	-	-	-	-	-	-	-	67.6	149.0	0.09	6 x M10	
VTX1 M 1330	1330	405	15.9	195	7.7	522	20.5	-	-	-	-	-	-	-	-	-	72.0	158.7	0.09	6 x M10	

The block length and weight are determined by the number of cells in the block.
All tabulated dimensions are maximum values.

* rigid connector included.

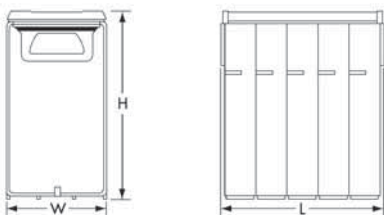

Performance after prolonged float charge of fully charged cells

Available amperes at +20°C ± 5°C (+68°F ± 9°F)

Final voltage: 1.00 V/cell

Vantex type	C _s Ah	HOURS							MINUTES							SECONDS		
		10 h	8 h	5 h	3 h	2 h	1.5 h	1 h	45 min	30 min	20 min	15 min	10 min	5 min	1 min	30 s	5 s	1 s
VTX1 L 15	15	1.56	1.93	3.00	4.63	5.91	6.79	8.32	9.58	11.2	12.4	13.4	14.8	16.6	18.0	20.0	24.7	28.6
VTX1 L 30	30	3.12	3.86	6.00	9.26	11.8	13.6	16.6	19.2	22.4	24.8	26.9	29.5	33.1	36.0	40.0	49.5	57.3
VTX1 L 47	47	4.89	6.05	9.40	14.5	18.5	21.3	26.1	30.0	35.1	38.8	42.1	46.2	51.9	56.4	62.7	77.5	89.7
VTX1 L 62	62	6.45	7.98	12.4	19.1	24.4	28.1	34.4	39.6	46.3	51.2	55.6	61.0	68.5	74.4	82.7	102	118
VTX1 L 75	75	7.80	9.66	15.0	23.2	29.5	34.0	41.6	47.9	56.0	62.0	67.2	73.8	82.8	90.0	100	124	143
VTX1 L 95	95	9.88	12.2	19.0	30.1	37.8	43.0	50.9	56.4	63.1	66.9	69.9	77.5	88.9	86.7	94.0	112	122
VTX1 L 110	110	11.4	14.2	22.0	34.9	43.8	49.8	59.0	65.3	73.0	77.5	81.0	89.8	103	100	109	130	141
VTX1 L 140	140	14.6	18.0	28.0	44.4	55.8	63.4	75.0	83.1	93.0	98.7	103	114	131	128	139	165	180
VTX1 L 185	185	19.2	23.8	37.0	58.6	73.7	83.8	99.1	110	123	130	136	151	173	169	183	218	238
VTX1 L 235	235	24.4	30.3	47.0	74.5	93.6	106	126	139	156	166	173	192	220	214	233	277	302
VTX1 L 280	280	29.1	36.1	56.0	88.7	112	127	150	166	186	197	206	228	262	256	277	330	360
VTX1 L 325	325	33.8	41.8	65.0	103	129	147	174	193	216	229	239	265	304	297	322	383	418
VTX1 L 375	375	39.0	48.3	75.0	119	149	170	201	223	249	264	276	306	351	342	371	442	482
VTX1 L 420	420	43.7	54.1	84.0	133	167	190	225	249	279	296	309	343	393	383	416	495	540
VTX1 L 470	470	48.9	60.5	94.0	149	187	213	252	279	312	331	346	384	440	429	465	554	604
VTX1 L 515	515	53.6	66.3	103	163	205	233	276	306	342	363	379	420	482	470	510	607	662
VTX1 L 560	560	58.2	72.1	112	177	223	254	300	332	372	395	412	457	524	511	554	660	719
VTX1 L 610	610	63.4	78.5	122	193	243	276	327	362	405	430	449	498	571	557	604	719	784
VTX1 L 650	650	67.6	83.7	130	206	259	294	348	386	432	458	478	530	608	593	643	767	835
VTX1 L 700	700	72.8	90.1	140	222	279	317	375	416	465	493	515	571	655	639	693	826	899
VTX1 L 750	750	78.0	96.6	150	238	299	340	402	445	498	529	552	612	702	684	742	885	963
VTX1 L 800	800	83.2	103	160	253	319	362	429	475	531	564	589	653	749	730	792	943	1028
VTX1 L 840	840	87.4	108	168	266	335	380	450	499	558	592	618	685	786	767	831	991	1079
VTX1 L 890	890	92.6	115	178	282	354	403	477	528	591	627	655	726	833	812	881	1050	1143
VTX1 L 940	940	97.8	121	188	298	374	426	504	558	624	662	692	767	880	858	930	1109	1208
VTX1 L 980	980	102	126	196	311	390	444	525	582	651	691	721	800	917	894	970	1156	1259
VTX1 L 1030	1030	107	133	206	326	410	467	552	611	684	726	758	840	964	940	1020	1215	1323
VTX1 L 1120	1120	116	144	224	355	446	507	600	665	744	789	824	914	1048	1022	1109	1321	1439
VTX1 L 1220	1220	127	157	244	387	486	553	654	724	810	860	898	996	1142	1113	1208	1439	1567
VTX1 L 1300	1300	135	167	260	412	518	589	697	772	863	916	957	1061	1217	1186	1287	1533	1670
VTX1 L 1400	1400	146	180	280	444	558	634	750	831	930	987	1030	1142	1310	1278	1386	1651	1799
VTX1 L 1500	1500	156	193	300	475	597	679	804	890	996	1057	1104	1224	1404	1369	1485	1769	1927
VTX1 L 1600	1600	166	206	320	507	637	725	857	950	1062	1128	1178	1306	1498	1460	1584	1887	2055
VTX1 L 1700	1700	177	219	340	539	677	770	911	1009	1129	1198	1251	1387	1591	1551	1683	2005	2184

Performance after prolonged float charge of fully charged cells

Available amperes at +20°C ± 5°C (+68°F ± 9°F)

Final voltage: 1.05 V/cell

Vantex type	C _s Ah	HOURS							MINUTES							SECONDS		
		10 h	8 h	5 h	3 h	2 h	1.5 h	1 h	45 min	30 min	20 min	15 min	10 min	5 min	1 min	30 s	5 s	1 s
VTX1 L 15	15	1.55	1.90	2.91	4.14	5.22	5.88	7.08	7.90	9.01	9.95	10.8	11.8	13.3	14.7	16.4	20.5	23.5
VTX1 L 30	30	3.09	3.81	5.82	8.28	10.4	11.8	14.2	15.8	18.0	19.9	21.5	23.6	26.6	29.4	32.8	41.0	47.0
VTX1 L 47	47	4.84	5.96	9.12	13.0	16.4	18.4	22.2	24.8	28.2	31.2	33.7	36.9	41.7	46.0	51.3	64.2	73.6
VTX1 L 62	62	6.39	7.87	12.0	17.1	21.6	24.3	29.3	32.7	37.2	41.1	44.5	48.7	55.1	60.7	67.7	84.6	97.0
VTX1 L 75	75	7.73	9.52	14.6	20.7	26.1	29.4	35.4	39.5	45.0	49.8	53.8	58.9	66.6	73.4	81.9	102	117
VTX1 L 95	95	9.79	12.1	18.4	26.8	33.5	37.8	42.9	46.8	52.2	56.3	59.3	61.4	67.5	70.9	77.2	92.4	100
VTX1 L 110	110	11.3	14.0	21.3	31.0	38.8	43.7	49.7	54.2	60.5	65.2	68.6	71.1	78.1	82.1	89.4	107	116
VTX1 L 140	140	14.4	17.8	27.2	39.5	49.3	55.7	63.3	69.0	77.0	83.0	87.4	90.6	99.5	104	114	136	147
VTX1 L 185	185	19.1	23.5	35.9	52.2	65.2	73.6	83.6	91.2	102	110	115	120	131	138	150	180	195
VTX1 L 235	235	24.2	29.8	45.6	66.3	82.8	93.4	106	116	129	139	147	152	167	175	191	229	247
VTX1 L 280	280	28.8	35.5	54.3	79.0	98.7	111	127	138	154	166	175	181	199	209	228	272	295
VTX1 L 325	325	33.5	41.2	63.1	91.7	115	129	147	160	179	193	203	210	231	242	264	316	342
VTX1 L 375	375	38.6	47.6	72.8	106	132	149	170	185	206	222	234	243	266	280	305	365	395
VTX1 L 420	420	43.3	53.3	81.5	118	148	167	190	207	231	249	262	272	298	313	341	408	442
VTX1 L 470	470	48.4	59.6	91.2	133	166	187	212	232	258	278	293	304	334	351	382	457	495
VTX1 L 515	515	53.0	65.3	99.9	145	181	205	233	254	283	305	321	333	366	384	418	501	542
VTX1 L 560	560	57.7	71.1	109	158	197	223	253	276	308	332	349	362	398	418	455	545	589
VTX1 L 610	610	62.8	77.4	118	172	215	243	276	301	335	361	381	395	433	455	496	593	642
VTX1 L 650	650	67.0	82.5	126	183	229	258	294	320	357	385	406	420	462	485	528	632	684
VTX1 L 700	700	72.1	88.8	136	197	247	278	316	345	385	415	437	453	497	522	569	681	737
VTX1 L 750	750	77.3	95.2	146	212	264	298	339	370	412	444	468	485	533	559	609	729	789
VTX1 L 800	800	82.4	102	155	226	282	318	362	394	440	474	499	517	568	597	650	778	842
VTX1 L 840	840	86.5	107	163	237	296	334	380	414	462	498	524	543	597	627	683	817	884
VTX1 L 890	890	91.7	113	173	251	314	354	402	439	489	527	555	576	632	664	723	865	937
VTX1 L 940	940	96.8	119	182	265	331	374	425	463	517	557	587	608	668	701	764	914	989
VTX1 L 980	980	101	124	190	276	345	390	443	483	539	581	612	634	696	731	796	953	1031
VTX1 L 1030	1030	106	131	200	291	363	410	466	508	566	610	643	666	732	768	837	1002	1084
VTX1 L 1120	1120	115	142	217	316	395	445	506	552	616	664	699	724	796	835	910	1089	1179
VTX1 L 1220	1220	126	155	237	344	430	485	551	601	671	723	761	789	867	910	991	1186	1284
VTX1 L 1300	1300	134	165	252	367	458	517	588	641	715	770	811	841	924	970	1056	1264	1368
VTX1 L 1400	1400	144	178	272	395	493	557	633	690	770	830	874	906	995	1044	1138	1361	1473
VTX1 L 1500	1500	155	190	291	423	529	596	678	739	825	889	936	970	1066	1119	1219	1459	1578
VTX1 L 1600	1600	165	203	310	451	564	636	723	789	880	948	998	1035	1137	1193	1300	1556	1684
VTX1 L 1700	1700	175	216	330	480	599	676	768	838	935	1007	1061	1100	1208	1268	1381	1653	1789

Performance after prolonged float charge of fully charged cells

Available amperes at +20°C ± 5°C (+68°F ± 9°F)

Final voltage: 1.10 V/cell

Vantex type	C _s Ah	HOURS							MINUTES							SECONDS		
		10 h	8 h	5 h	3 h	2 h	1.5 h	1 h	45 min	30 min	20 min	15 min	10 min	5 min	1 min	30 s	5 s	1 s
VTX1 L 15	15	1.50	1.82	2.62	3.56	4.31	4.92	5.85	6.38	7.20	8.10	8.21	9.07	10.4	11.3	12.8	16.0	17.9
VTX1 L 30	30	3.00	3.64	5.24	7.13	8.61	9.84	11.7	12.8	14.4	16.2	16.4	18.1	20.7	22.6	25.5	31.9	35.8
VTX1 L 47	47	4.70	5.70	8.22	11.2	13.5	15.4	18.3	20.0	22.6	25.4	25.7	28.4	32.5	35.4	40.0	50.0	56.1
VTX1 L 62	62	6.20	7.52	10.8	14.7	17.8	20.3	24.2	26.4	29.8	33.5	33.9	37.5	42.9	46.7	52.7	66.0	74.0
VTX1 L 75	75	7.50	9.10	13.1	17.8	21.5	24.6	29.3	31.9	36.0	40.5	41.0	45.4	51.8	56.5	63.8	79.9	89.5
VTX1 L 95	95	9.50	11.5	16.6	22.7	27.3	30.4	34.8	37.5	41.3	44.9	45.1	48.8	51.7	55.2	60.5	71.5	77.3
VTX1 L 110	110	11.0	13.3	19.2	26.3	31.6	35.2	40.3	43.5	47.9	52.0	52.3	56.5	59.9	64.0	70.0	82.8	89.5
VTX1 L 140	140	14.0	17.0	24.4	33.5	40.2	44.8	51.3	55.3	60.9	66.2	66.5	72.0	76.2	81.4	89.1	105	114
VTX1 L 185	185	18.5	22.4	32.3	44.2	53.1	59.2	67.8	73.1	80.5	87.4	87.9	95.1	101	108	118	139	151
VTX1 L 235	235	23.5	28.5	41.0	56.2	67.4	75.2	86.2	92.9	102	111	112	121	128	137	150	177	191
VTX1 L 280	280	28.0	34.0	48.8	66.9	80.4	89.6	103	111	122	132	133	144	152	163	178	211	228
VTX1 L 325	325	32.5	39.4	56.7	77.7	93.3	104	119	128	141	154	154	167	177	189	207	245	265
VTX1 L 375	375	37.5	45.5	65.4	89.7	108	120	137	148	163	177	178	193	204	218	239	282	305
VTX1 L 420	420	42.0	50.9	73.3	100	121	134	154	166	183	198	200	216	229	244	267	316	342
VTX1 L 470	470	47.0	57.0	82.0	112	135	150	172	186	204	222	223	242	256	273	299	354	383
VTX1 L 515	515	51.5	62.5	89.8	123	148	165	189	204	224	243	245	265	280	299	328	388	419
VTX1 L 560	560	56.0	67.9	97.7	134	161	179	205	221	244	265	266	288	305	326	356	422	456
VTX1 L 610	610	61.0	74.0	106	146	175	195	224	241	265	288	290	314	332	355	388	459	497
VTX1 L 650	650	65.0	78.8	113	155	187	208	238	257	283	307	309	334	354	378	414	489	529
VTX1 L 700	700	70.0	84.9	122	167	201	224	257	277	305	331	333	360	381	407	446	527	570
VTX1 L 750	750	75.0	91.0	131	179	215	240	275	296	326	354	356	386	408	436	477	565	610
VTX1 L 800	800	80.0	97.0	140	191	230	256	293	316	348	378	380	411	435	465	509	602	651
VTX1 L 840	840	84.0	102	147	201	241	269	308	332	365	397	399	432	457	488	535	632	684
VTX1 L 890	890	89.0	108	155	213	255	285	326	352	387	421	423	458	484	517	566	670	724
VTX1 L 940	940	94.0	114	164	225	270	301	345	371	409	444	447	483	512	547	598	708	765
VTX1 L 980	980	98.0	119	171	234	281	314	359	387	426	463	466	504	533	570	624	738	798
VTX1 L 1030	1030	103	125	180	246	296	330	378	407	448	487	489	530	561	599	656	775	838
VTX1 L 1120	1120	112	136	195	268	321	358	411	443	487	529	532	576	610	651	713	843	912
VTX1 L 1220	1220	122	148	213	292	350	390	447	482	531	576	580	627	664	709	777	918	993
VTX1 L 1300	1300	130	158	227	311	373	416	477	514	566	614	618	668	708	756	827	979	1058
VTX1 L 1400	1400	140	170	244	335	402	448	513	553	609	662	665	720	762	814	891	1054	1140
VTX1 L 1500	1500	150	182	262	359	431	480	550	593	653	709	713	771	816	872	955	1129	1221
VTX1 L 1600	1600	160	194	279	383	459	512	587	632	696	756	760	823	871	930	1018	1204	1302
VTX1 L 1700	1700	170	206	297	406	488	544	623	672	740	803	808	874	925	988	1082	1280	1384

Performance after prolonged float charge of fully charged cells

Available amperes at +20°C ± 5°C (+68°F ± 9°F)

Final voltage: 1.14 V/cell

Vantex type	C _s Ah	HOURS							MINUTES							SECONDS		
		10 h	8 h	5 h	3 h	2 h	1.5 h	1 h	45 min	30 min	20 min	15 min	10 min	5 min	1 min	30 s	5 s	1 s
VTX1 L 15	15	1.41	1.66	2.19	2.84	3.47	3.90	4.43	4.90	5.54	6.14	6.72	7.25	8.07	8.79	9.88	12.6	14.1
VTX1 L 30	30	2.82	3.31	4.38	5.68	6.93	7.80	8.86	9.79	11.1	12.3	13.4	14.5	16.1	17.6	19.8	25.1	28.1
VTX1 L 47	47	4.42	5.19	6.87	8.90	10.9	12.2	13.9	15.3	17.4	19.2	21.1	22.7	25.3	27.5	30.9	39.3	44.1
VTX1 L 62	62	5.83	6.84	9.06	11.7	14.3	16.1	18.3	20.2	22.9	25.4	27.8	29.9	33.4	36.3	40.8	51.9	58.1
VTX1 L 75	75	7.05	8.28	11.0	14.2	17.3	19.5	22.1	24.5	27.7	30.7	33.6	36.2	40.4	43.9	49.4	62.8	70.3
VTX1 L 95	95	8.93	10.5	13.9	17.5	20.8	23.0	26.0	28.3	31.0	33.9	36.7	39.9	45.6	42.4	47.2	56.2	60.4
VTX1 L 110	110	10.3	12.1	16.1	20.2	24.1	26.7	30.1	32.7	35.9	39.3	42.5	46.2	52.8	49.1	54.6	65.1	70.0
VTX1 L 140	140	13.2	15.5	20.5	25.8	30.7	34.0	38.3	41.7	45.7	50.0	54.1	58.8	67.2	62.5	69.5	82.8	89.1
VTX1 L 185	185	17.4	20.4	27.0	34.0	40.6	44.9	50.6	55.1	60.4	66.0	71.5	77.7	88.8	82.6	91.9	109	118
VTX1 L 235	235	22.1	25.9	34.3	43.2	51.6	57.0	64.3	69.9	76.8	83.9	90.8	98.7	112.9	105	117	139	149
VTX1 L 280	280	26.3	30.9	40.9	51.5	61.4	67.9	76.6	83.3	91.4	100	108	118	134	125	139	166	178
VTX1 L 325	325	30.6	35.9	47.5	59.8	71.3	78.8	88.9	96.7	106	116	126	137	156	145	161	192	207
VTX1 L 375	375	35.3	41.4	54.8	69.0	82.3	90.9	103	112	122	134	145	158	180	167	186	222	239
VTX1 L 420	420	39.5	46.4	61.4	77.3	92.2	102	115	125	137	150	162	176	202	187	209	248	267
VTX1 L 470	470	44.2	51.9	68.7	86.5	103	114	129	140	154	168	182	197	226	210	233	278	299
VTX1 L 515	515	48.4	56.9	75.2	94.8	113	125	141	153	168	184	199	216	247	230	256	305	328
VTX1 L 560	560	52.6	61.8	81.8	103	123	136	153	167	183	200	216	235	269	250	278	331	356
VTX1 L 610	610	57.3	67.3	89.1	112	134	148	167	182	199	218	236	256	293	272	303	361	388
VTX1 L 650	650	61.1	71.8	95.0	120	143	158	178	193	212	232	251	273	312	290	323	384	413
VTX1 L 700	700	65.8	77.3	102	129	154	170	192	208	229	250	270	294	336	312	348	414	445
VTX1 L 750	750	70.5	82.8	110	138	165	182	205	223	245	268	290	315	360	335	372	444	477
VTX1 L 800	800	75.2	88.3	117	147	176	194	219	238	261	286	309	336	384	357	397	473	509
VTX1 L 840	840	79.0	92.7	123	155	184	204	230	250	274	300	325	353	403	375	417	497	534
VTX1 L 890	890	83.7	98.3	130	164	195	216	244	265	291	318	344	374	427	397	442	526	566
VTX1 L 940	940	88.4	104	137	173	206	228	257	280	307	336	363	395	451	420	467	556	598
VTX1 L 980	980	92.1	108	143	180	215	238	268	292	320	350	379	412	471	437	487	580	623
VTX1 L 1030	1030	96.8	114	150	190	226	250	282	307	336	368	398	433	495	460	512	609	655
VTX1 L 1120	1120	105	124	164	206	246	272	306	333	366	400	433	470	538	500	556	662	712
VTX1 L 1220	1220	115	135	178	224	268	296	334	363	398	436	471	512	586	545	606	722	776
VTX1 L 1300	1300	122	144	190	239	285	315	356	387	425	464	502	546	624	580	646	769	827
VTX1 L 1400	1400	132	155	205	258	307	340	383	417	457	500	541	588	672	625	695	828	891
VTX1 L 1500	1500	141	166	219	276	329	364	410	446	490	536	580	630	720	670	745	887	954
VTX1 L 1600	1600	150	177	234	294	351	388	438	476	523	571	618	672	768	714	795	946	1018
VTX1 L 1700	1700	160	188	248	313	373	412	465	506	555	607	657	714	816	759	844	1006	1081

Performance after prolonged float charge of fully charged cells

Available amperes at +20°C ± 5°C (+68°F ± 9°F)

Final voltage: 1.00 V/cell

Vantex type	C ₅ Ah	HOURS							MINUTES							SECONDS		
		10 h	8 h	5 h	3 h	2 h	1.5 h	1 h	45 min	30 min	20 min	15 min	10 min	5 min	1 min	30 s	5 s	1 s
VTX1 M 8	8	0.82	1.02	1.60	2.60	3.72	4.66	6.61	7.91	9.79	11.6	12.9	14.3	16.9	17.4	19.1	23.7	27.5
VTX1 M 16	16	1.65	2.04	3.20	5.20	7.44	9.32	13.2	15.8	19.6	23.1	25.9	28.7	33.7	34.8	38.2	47.5	55.1
VTX1 M 24	24	2.47	3.06	4.80	7.80	11.2	14.0	19.8	23.7	29.4	34.7	38.8	43.0	50.6	52.2	57.3	71.2	82.6
VTX1 M 32	32	3.30	4.08	6.40	10.4	14.9	18.6	26.4	31.6	39.1	46.2	51.7	57.4	67.5	69.6	76.5	95.0	110
VTX1 M 40	40	4.12	5.10	8.00	13.0	18.6	23.3	33.1	39.6	48.9	57.8	64.7	71.7	84.4	87.0	95.6	119	138
VTX1 M 48	48	4.94	6.12	9.60	15.6	22.3	28.0	39.7	47.5	58.7	69.4	77.6	86.1	101	104	115	142	165
VTX1 M 65	65	6.70	8.29	13.0	21.1	30.2	37.9	53.7	64.3	79.5	93.9	105	117	137	141	155	193	224
VTX1 M 75	75	7.73	9.56	15.0	24.3	34.5	43.2	62.7	74.6	91.1	104	111	118	135	137	147	174	191
VTX1 M 100	100	10.3	12.8	20.0	32.3	46.0	57.6	83.6	99.5	121	138	148	157	180	182	196	231	255
VTX1 M 125	125	12.9	15.9	25.0	40.4	57.5	72.0	105	124	152	173	185	196	225	228	245	289	318
VTX1 M 150	150	15.5	19.1	30.0	48.5	69.0	86.4	125	149	182	207	222	235	270	274	294	347	382
VTX1 M 170	170	17.5	21.7	34.0	55.0	78.2	97.9	142	169	206	235	251	267	306	310	334	393	433
VTX1 M 195	195	20.1	24.9	39.0	63.1	89.7	112	163	194	237	269	288	306	351	356	383	451	497
VTX1 M 220	220	22.7	28.1	44.0	71.1	101	127	184	219	267	304	325	345	396	401	432	509	560
VTX1 M 245	245	25.2	31.2	49.0	79.2	113	141	205	244	298	338	362	384	441	447	481	567	624
VTX1 M 270	270	27.8	34.4	54.0	87.3	124	156	226	269	328	373	399	424	486	493	530	625	688
VTX1 M 295	295	30.4	37.6	59.0	95.4	136	170	247	294	358	407	436	463	530	538	579	682	751
VTX1 M 320	320	33.0	40.8	64.0	103	147	184	268	318	389	442	473	502	575	584	628	740	815
VTX1 M 345	345	35.5	44.0	69.0	112	159	199	288	343	419	476	510	541	620	629	677	798	879
VTX1 M 370	370	38.1	47.2	74.0	120	170	213	309	368	449	511	547	580	665	675	726	856	943
VTX1 M 395	395	40.7	50.4	79.0	128	182	228	330	393	480	545	584	620	710	721	775	914	1006
VTX1 M 420	420	43.3	53.6	84.0	136	193	242	351	418	510	580	621	659	755	766	824	972	1070
VTX1 M 445	445	45.8	56.7	89.0	144	205	256	372	443	540	614	658	698	800	812	873	1029	1134
VTX1 M 490	490	50.5	62.5	98.0	158	225	282	410	488	595	676	725	769	881	894	961	1134	1248
VTX1 M 540	540	55.6	68.9	108	175	248	311	451	537	656	745	799	847	971	985	1060	1249	1376
VTX1 M 590	590	60.8	75.2	118	191	271	340	493	587	716	814	873	926	1061	1076	1158	1365	1503
VTX1 M 640	640	65.9	81.6	128	207	294	369	535	637	777	883	947	1004	1151	1168	1256	1481	1630
VTX1 M 690	690	71.1	88.0	138	223	317	397	577	687	838	952	1021	1082	1241	1259	1354	1596	1758
VTX1 M 740	740	76.2	94.4	148	239	340	426	619	736	899	1021	1095	1161	1331	1350	1452	1712	1885
VTX1 M 785	785	80.9	100	157	254	361	452	656	781	953	1084	1161	1231	1412	1432	1540	1816	2000
VTX1 M 835	835	86.0	106	167	270	384	481	698	831	1014	1153	1235	1310	1501	1523	1638	1932	2127
VTX1 M 885	885	91.2	113	177	286	407	510	740	881	1075	1222	1309	1388	1591	1615	1737	2047	2254
VTX1 M 935	935	96.3	119	187	302	430	539	782	930	1135	1291	1383	1467	1681	1706	1835	2163	2382
VTX1 M 985	985	101	126	197	318	453	567	823	980	1196	1360	1457	1545	1771	1797	1933	2279	2509
VTX1 M 1030	1030	106	131	206	333	474	593	861	1025	1251	1422	1524	1616	1852	1879	2021	2383	2624
VTX1 M 1130	1130	116	144	226	365	520	651	945	1124	1372	1560	1671	1773	2032	2062	2217	2614	2879
VTX1 M 1230	1230	127	157	246	398	566	708	1028	1224	1494	1698	1819	1930	2212	2244	2414	2845	3133
VTX1 M 1330	1330	137	170	266	430	612	766	1112	1323	1615	1836	1967	2086	2392	2427	2610	3077	3388

Performance after prolonged float charge of fully charged cells

Available amperes at +20°C ± 5°C (+68°F ± 9°F)

Final voltage: 1.05 V/cell

Vantex type	C _s Ah	HOURS							MINUTES							SECONDS		
		10 h	8 h	5 h	3 h	2 h	1.5 h	1 h	45 min	30 min	20 min	15 min	10 min	5 min	1 min	30 s	5 s	1 s
VTX1 M 8	8	0.82	1.02	1.58	2.56	3.53	4.39	5.64	6.68	8.27	9.56	10.5	11.6	13.8	15.0	16.4	20.3	23.4
VTX1 M 16	16	1.63	2.04	3.17	5.12	7.06	8.77	11.3	13.4	16.5	19.1	21.0	23.2	27.6	29.9	32.7	40.6	46.8
VTX1 M 24	24	2.45	3.06	4.75	7.68	10.6	13.2	16.9	20.0	24.8	28.7	31.5	34.8	41.5	44.9	49.1	60.9	70.2
VTX1 M 32	32	3.26	4.08	6.34	10.2	14.1	17.5	22.6	26.7	33.1	38.2	42.0	46.4	55.3	59.8	65.5	81.2	93.6
VTX1 M 40	40	4.08	5.10	7.92	12.8	17.7	21.9	28.2	33.4	41.3	47.8	52.5	58.1	69.1	74.8	81.9	101	117
VTX1 M 48	48	4.90	6.11	9.50	15.4	21.2	26.3	33.8	40.1	49.6	57.4	63.0	69.7	82.9	89.8	98.2	122	140
VTX1 M 65	65	6.63	8.28	12.9	20.8	28.7	35.6	45.8	54.2	67.2	77.7	85.3	94.3	112	122	133	165	190
VTX1 M 75	75	7.65	9.55	14.9	23.8	33.1	41.4	54.2	63.8	76.2	85.9	91.0	100	108	115	125	148	161
VTX1 M 100	100	10.2	12.7	19.9	31.8	44.1	55.1	72.2	85.1	102	115	121	133	144	154	167	197	214
VTX1 M 125	125	12.8	15.9	24.9	39.7	55.2	68.9	90.3	106	127	143	152	166	180	192	208	247	268
VTX1 M 150	150	15.3	19.1	29.9	47.7	66.2	82.7	108	128	152	172	182	199	216	231	250	296	321
VTX1 M 170	170	17.3	21.7	33.8	54.0	75.0	93.7	123	145	173	195	206	226	245	261	283	335	364
VTX1 M 195	195	19.9	24.8	38.8	61.9	86.1	108	141	166	198	223	237	259	281	300	325	385	418
VTX1 M 220	220	22.4	28.0	43.8	69.9	97.1	121	159	187	224	252	267	292	317	338	367	434	471
VTX1 M 245	245	25.0	31.2	48.8	77.8	108	135	177	209	249	281	297	325	353	377	408	483	525
VTX1 M 270	270	27.5	34.4	53.7	85.8	119	149	195	230	274	309	328	359	389	415	450	532	578
VTX1 M 295	295	30.1	37.6	58.7	93.7	130	163	213	251	300	338	358	392	425	453	491	582	632
VTX1 M 320	320	32.6	40.8	63.7	102	141	176	231	272	325	367	388	425	461	492	533	631	685
VTX1 M 345	345	35.2	43.9	68.7	110	152	190	249	294	351	395	419	458	497	530	575	680	739
VTX1 M 370	370	37.7	47.1	73.6	118	163	204	267	315	376	424	449	492	533	569	616	730	793
VTX1 M 395	395	40.3	50.3	78.6	125	174	218	285	336	401	452	479	525	569	607	658	779	846
VTX1 M 420	420	42.8	53.5	83.6	133	185	232	303	358	427	481	510	558	605	645	700	828	900
VTX1 M 445	445	45.4	56.7	88.6	141	196	245	321	379	452	510	540	591	641	684	741	878	953
VTX1 M 490	490	50.0	62.4	97.5	156	216	270	354	417	498	561	595	651	706	753	816	966	1050
VTX1 M 540	540	55.1	68.8	107	172	238	298	390	460	549	619	655	717	778	830	900	1065	1157
VTX1 M 590	590	60.2	75.2	117	187	260	325	426	502	600	676	716	784	850	907	983	1163	1264
VTX1 M 640	640	65.3	81.5	127	203	282	353	462	545	650	733	777	850	922	984	1066	1262	1371
VTX1 M 690	690	70.4	87.9	137	219	305	381	498	587	701	790	837	917	994	1060	1150	1361	1478
VTX1 M 740	740	75.5	94.3	147	235	327	408	534	630	752	848	898	983	1066	1137	1233	1459	1585
VTX1 M 785	785	80.1	100	156	249	346	433	567	668	798	899	953	1043	1130	1206	1308	1548	1681
VTX1 M 835	835	85.2	106	166	265	369	460	603	711	849	956	1013	1109	1202	1283	1391	1647	1789
VTX1 M 885	885	90.3	113	176	281	391	488	639	753	900	1014	1074	1176	1274	1360	1474	1745	1896
VTX1 M 935	935	95.4	119	186	297	413	516	675	796	950	1071	1135	1242	1346	1437	1558	1844	2003
VTX1 M 985	985	100	125	196	313	435	543	711	838	1001	1128	1195	1308	1418	1514	1641	1942	2110
VTX1 M 1030	1030	105	131	205	327	455	568	744	877	1047	1180	1250	1368	1483	1583	1716	2031	2206
VTX1 M 1130	1130	115	144	225	359	499	623	816	962	1149	1294	1371	1501	1627	1737	1883	2228	2420
VTX1 M 1230	1230	125	157	245	391	543	678	888	1047	1250	1409	1493	1634	1771	1890	2049	2426	2635
VTX1 M 1330	1330	136	169	265	422	587	733	960	1132	1352	1523	1614	1767	1915	2044	2216	2623	2849

Performance after prolonged float charge of fully charged cells

Available amperes at +20°C ± 5°C (+68°F ± 9°F)

Final voltage: 1.10 V/cell

Vantex type	C ₅ Ah	HOURS							MINUTES						SECONDS			
		10 h	8 h	5 h	3 h	2 h	1.5 h	1 h	45 min	30 min	20 min	15 min	10 min	5 min	1 min	30 s	5 s	1 s
VTX1 M 8	8	0.81	1.00	1.55	2.48	3.34	4.01	4.94	5.64	6.36	7.39	7.98	8.76	10.2	11.9	13.2	16.3	18.8
VTX1 M 16	16	1.62	2.00	3.10	4.96	6.69	8.03	9.88	11.3	12.7	14.8	16.0	17.5	20.4	23.9	26.5	32.7	37.5
VTX1 M 24	24	2.42	3.00	4.66	7.44	10.0	12.0	14.8	16.9	19.1	22.2	23.9	26.3	30.6	35.8	39.7	49.0	56.3
VTX1 M 32	32	3.23	4.00	6.21	9.92	13.4	16.1	19.8	22.6	25.5	29.6	31.9	35.0	40.9	47.8	52.9	65.3	75.0
VTX1 M 40	40	4.04	5.00	7.76	12.4	16.7	20.1	24.7	28.2	31.8	37.0	39.9	43.8	51.1	59.7	66.2	81.7	93.8
VTX1 M 48	48	4.85	6.00	9.31	14.9	20.1	24.1	29.6	33.9	38.2	44.4	47.9	52.5	61.3	71.6	79.4	98.0	113
VTX1 M 65	65	6.57	8.13	12.6	20.2	27.2	32.6	40.2	45.9	51.7	60.1	64.8	71.1	83.0	97.0	107	133	152
VTX1 M 75	75	7.58	9.38	14.7	23.3	31.7	38.2	47.0	52.9	59.1	65.9	70.7	75.2	82.1	91.6	98.8	117	127
VTX1 M 100	100	10.1	12.5	19.6	31.0	42.3	50.9	62.6	70.6	78.8	87.9	94.2	100	109	122	132	156	169
VTX1 M 125	125	12.6	15.6	24.5	38.8	52.8	63.6	78.3	88.2	98.5	110	118	125	137	153	165	195	212
VTX1 M 150	150	15.2	18.8	29.4	46.5	63.4	76.4	94.0	106	118	132	141	150	164	183	198	234	254
VTX1 M 170	170	17.2	21.3	33.3	52.7	71.9	86.5	106	120	134	149	160	171	186	208	224	265	288
VTX1 M 195	195	19.7	24.4	38.2	60.5	82.4	99.3	122	138	154	171	184	196	213	238	257	304	330
VTX1 M 220	220	22.2	27.5	43.1	68.2	93.0	112	138	155	173	193	207	221	241	269	290	343	372
VTX1 M 245	245	24.7	30.6	48.0	76.0	104	125	153	173	193	215	231	246	268	299	323	381	415
VTX1 M 270	270	27.3	33.8	52.9	83.7	114	137	169	191	213	237	254	271	295	330	356	420	457
VTX1 M 295	295	29.8	36.9	57.8	91.5	125	150	185	208	232	259	278	296	323	360	389	459	499
VTX1 M 320	320	32.3	40.0	62.7	99.2	135	163	200	226	252	281	302	321	350	391	422	498	542
VTX1 M 345	345	34.8	43.1	67.6	107	146	176	216	243	272	303	325	346	378	421	455	537	584
VTX1 M 370	370	37.4	46.3	72.5	115	156	188	232	261	291	325	349	371	405	452	488	576	626
VTX1 M 395	395	39.9	49.4	77.4	122	167	201	247	279	311	347	372	396	432	482	521	615	669
VTX1 M 420	420	42.4	52.5	82.3	130	178	214	263	296	331	369	396	421	460	513	553	654	711
VTX1 M 445	445	44.9	55.6	87.2	138	188	227	279	314	351	391	419	446	487	543	586	693	753
VTX1 M 490	490	49.5	61.3	96.0	152	207	249	307	346	386	431	462	492	536	598	646	763	829
VTX1 M 540	540	54.5	67.5	106	167	228	275	338	381	425	475	509	542	591	659	712	841	914
VTX1 M 590	590	59.6	73.8	116	183	249	300	370	416	465	518	556	592	646	720	778	919	999
VTX1 M 640	640	64.6	80.0	125	198	271	326	401	452	504	562	603	642	700	781	843	996	1083
VTX1 M 690	690	69.7	86.3	135	214	292	351	432	487	544	606	650	692	755	842	909	1074	1168
VTX1 M 740	740	74.7	92.5	145	229	313	377	464	522	583	650	697	742	810	903	975	1152	1252
VTX1 M 785	785	79.3	98.1	154	243	332	400	492	554	618	690	740	788	859	958	1035	1222	1329
VTX1 M 835	835	84.3	104	164	259	353	425	523	589	658	734	787	838	914	1019	1100	1300	1413
VTX1 M 885	885	89.4	111	173	274	374	451	554	624	697	778	834	888	969	1081	1166	1378	1498
VTX1 M 935	935	94.4	117	183	290	395	476	586	660	737	822	881	938	1023	1142	1232	1456	1583
VTX1 M 985	985	99.5	123	193	305	416	501	617	695	776	866	928	988	1078	1203	1298	1534	1667
VTX1 M 1030	1030	104	129	202	319	435	524	645	727	811	905	971	1033	1127	1258	1357	1604	1743
VTX1 M 1130	1130	114	141	221	350	478	575	708	797	890	993	1065	1134	1237	1380	1489	1759	1913
VTX1 M 1230	1230	124	154	241	381	520	626	770	868	969	1081	1159	1234	1346	1502	1621	1915	2082
VTX1 M 1330	1330	134	166	261	412	562	677	833	938	1048	1169	1253	1334	1456	1624	1753	2071	2251

Performance after prolonged float charge of fully charged cells

Available amperes at +20°C ± 5°C (+68°F ± 9°F)

Final voltage: 1.14 V/cell

Vantex type	C _s Ah	HOURS							MINUTES							SECONDS		
		10 h	8 h	5 h	3 h	2 h	1.5 h	1 h	45 min	30 min	20 min	15 min	10 min	5 min	1 min	30 s	5 s	1 s
VTX1 M 8	8	0.78	0.97	1.50	2.28	2.82	3.12	3.77	4.30	4.98	5.72	6.16	6.83	8.29	9.74	10.8	13.3	15.2
VTX1 M 16	16	1.57	1.94	2.99	4.55	5.64	6.24	7.54	8.59	9.96	11.4	12.3	13.7	16.6	19.5	21.5	26.5	30.4
VTX1 M 24	24	2.35	2.91	4.49	6.83	8.46	9.35	11.3	12.9	14.9	17.2	18.5	20.5	24.9	29.2	32.3	39.8	45.5
VTX1 M 32	32	3.14	3.88	5.98	9.11	11.3	12.5	15.1	17.2	19.9	22.9	24.6	27.3	33.2	39.0	43.1	53.1	60.7
VTX1 M 40	40	3.92	4.85	7.48	11.4	14.1	15.6	18.8	21.5	24.9	28.6	30.8	34.2	41.5	48.7	53.9	66.3	75.9
VTX1 M 48	48	4.70	5.82	8.98	13.7	16.9	18.7	22.6	25.8	29.9	34.3	36.9	41.0	49.8	58.5	64.6	79.6	91.1
VTX1 M 65	65	6.37	7.88	12.2	18.5	22.9	25.3	30.6	34.9	40.5	46.5	50.0	55.5	67.4	79.2	87.5	108	123
VTX1 M 75	75	7.35	9.09	14.1	21.8	27.1	29.8	35.3	40.3	45.6	50.6	53.3	59.1	64.8	72.5	78.5	94	101
VTX1 M 100	100	9.80	12.1	18.8	29.1	36.1	39.8	47.1	53.7	60.8	67.5	71.0	78.8	86.4	96.7	105	125	135
VTX1 M 125	125	12.3	15.2	23.5	36.4	45.1	49.7	58.9	67.1	75.9	84.4	88.8	98.6	108	121	131	157	168
VTX1 M 150	150	14.7	18.2	28.2	43.7	54.2	59.6	70.7	80.6	91.1	101	107	118	130	145	157	188	202
VTX1 M 170	170	16.7	20.6	32.0	49.5	61.4	67.6	80.1	91.3	103	115	121	134	147	164	178	213	229
VTX1 M 195	195	19.1	23.6	36.7	56.7	70.4	77.5	91.9	105	118	132	139	154	168	189	204	245	263
VTX1 M 220	220	21.6	26.7	41.4	64.0	79.4	87.5	104	118	134	149	156	173	190	213	230	276	296
VTX1 M 245	245	24.0	29.7	46.1	71.3	88.5	97.4	115	132	149	165	174	193	212	237	256	307	330
VTX1 M 270	270	26.5	32.7	50.8	78.6	97.5	107	127	145	164	182	192	213	233	261	283	339	364
VTX1 M 295	295	28.9	35.8	55.5	85.8	107	117	139	158	179	199	210	233	255	285	309	370	397
VTX1 M 320	320	31.4	38.8	60.2	93.1	116	127	151	172	194	216	227	252	276	309	335	401	431
VTX1 M 345	345	33.8	41.8	64.9	100	125	137	163	185	210	233	245	272	298	334	361	433	465
VTX1 M 370	370	36.3	44.9	69.6	108	134	147	174	199	225	250	263	292	320	358	387	464	498
VTX1 M 395	395	38.7	47.9	74.3	115	143	157	186	212	240	267	281	311	341	382	413	496	532
VTX1 M 420	420	41.2	50.9	79.0	122	152	167	198	226	255	284	298	331	363	406	440	527	565
VTX1 M 445	445	43.6	54.0	83.7	129	161	177	210	239	270	300	316	351	384	430	466	558	599
VTX1 M 490	490	48.0	59.4	92.2	143	177	195	231	263	298	331	348	386	423	474	513	615	660
VTX1 M 540	540	52.9	65.5	102	157	195	215	254	290	328	365	384	426	467	522	565	677	727
VTX1 M 590	590	57.8	71.5	111	172	213	235	278	317	358	398	419	465	510	571	617	740	794
VTX1 M 640	640	62.7	77.6	120	186	231	254	302	344	389	432	455	505	553	619	670	803	862
VTX1 M 690	690	67.6	83.7	130	201	249	274	325	371	419	466	490	544	596	667	722	866	929
VTX1 M 740	740	72.5	89.7	139	215	267	294	349	397	450	500	526	583	639	716	774	928	996
VTX1 M 785	785	76.9	95.2	148	228	283	312	370	422	477	530	558	619	678	759	822	985	1057
VTX1 M 835	835	81.8	101	157	243	301	332	393	448	507	564	593	658	721	807	874	1048	1124
VTX1 M 885	885	86.7	107	166	258	320	352	417	475	538	597	629	698	765	856	926	1110	1192
VTX1 M 935	935	91.6	113	176	272	338	372	441	502	568	631	664	737	808	904	978	1173	1259
VTX1 M 985	985	96.5	119	185	287	356	392	464	529	598	665	700	777	851	952	1031	1236	1326
VTX1 M 1030	1030	101	125	194	300	372	410	485	553	626	695	732	812	890	996	1078	1292	1387
VTX1 M 1130	1130	111	137	213	329	408	449	532	607	686	763	803	891	976	1093	1183	1418	1521
VTX1 M 1230	1230	121	149	231	358	444	489	580	661	747	830	874	970	1063	1189	1287	1543	1656
VTX1 M 1330	1330	130	161	250	387	480	529	627	714	808	898	945	1049	1149	1286	1392	1669	1791



Vantage

Ultra-low maintenance batteries

Delivering quality

ALCAD

ALCAD Vantage

Ultra-low maintenance batteries

Ultra-high reliability, ultra-low maintenance

Alcad Vantage... a powerful combination of proven pocket-plate construction and advanced design from the world leader in industrial nickel-cadmium battery technology. With a 20-year life and ultra-low maintenance requirements, Vantage has become the cost-effective first choice – worldwide – for trouble-free standby power in the most demanding applications.

More reliable

Vantage can continue to supply power for 20 years or more thanks to its corrosion-free construction and Alcad's tried and tested pocket-plate technology. No physical plate degradation and no sudden death with resulting costly downtime.

Low life-cycle cost

The cost of ownership of a battery system can be calculated across three distinct phases: the initial investment, including the cost of purchase and installation; on-going maintenance costs, including unexpected and expensive downtime periods; finally, the battery replacement costs, which include the expense of disposal as well as renewal.

Vantage is the most cost-effective solution for any application – onshore or offshore – where long battery life, low maintenance costs, resistance to corrosion and total reliability are prime operating requirements.

More adaptable

Offshore oil and gas, emergency lighting, fire and security, telecoms, utilities, photovoltaics. You can depend upon Vantage for perfect peace of mind.

No water filling

No water filling is necessary during the Vantage 20-year service life because of the controlled recombination and the valve regulated venting system (topping-up is possible if required).

More durable

Vantage will survive treatment which would destroy lead acid batteries. This battery accepts ripple currents up to $0.2 C_5 A I_{eff}$ and can be over-discharged or reversed without damage. Prolonged abusive overcharge can easily be compensated by refurbishment with water.

More environmentally tolerant

Vantage performs in the most severe conditions and can operate over a temperature range from 0°C to $+40^{\circ}\text{C}$ ($+32^{\circ}\text{F}$ to $+104^{\circ}\text{F}$). It can survive extremes of temperature from as low as -50°C to as high as $+70^{\circ}\text{C}$ (-58°F to as high as $+158^{\circ}\text{F}$).

More manageable

Compact and lightweight, Vantage is easy to transport and install. It can be stored for one year without need of refresher charges.

Float-corrected data

Many nickel-cadmium batteries are used in stationary standby power applications where discharges occur infrequently and the battery is continuously charged by a float or constant potential charge. Under these circumstances there is a modification in the level of the discharge curve and allowances must be made for this when dimensioning the battery.

In order to simplify this process, the data Alcad supplies in this publication takes into account this phenomenon. The data published by Alcad is the performance after prolonged floating and it can be used directly to perform the battery calculation.

This phenomenon occurs with all nickel-cadmium batteries, but some other manufacturers of nickel-cadmium batteries may not take this effect into account in published data.

When calculating for deep discharges (0.65 V and 0.85 V) it is not necessary to take this effect into account.

Alcad recycle

Alcad also recycle old batteries as part of their responsibility to safeguard the environment.





Effect of charging voltage on water consumption

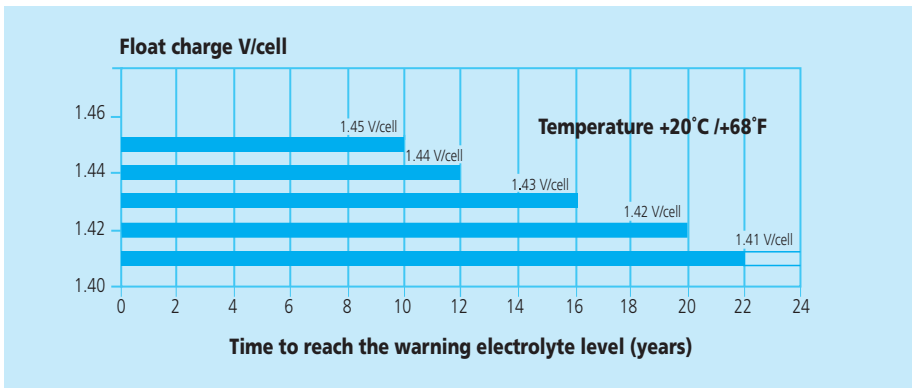

Available capacity on float charge from a fully discharged cell at +20°C to +25°C (+68°F to +77°F)

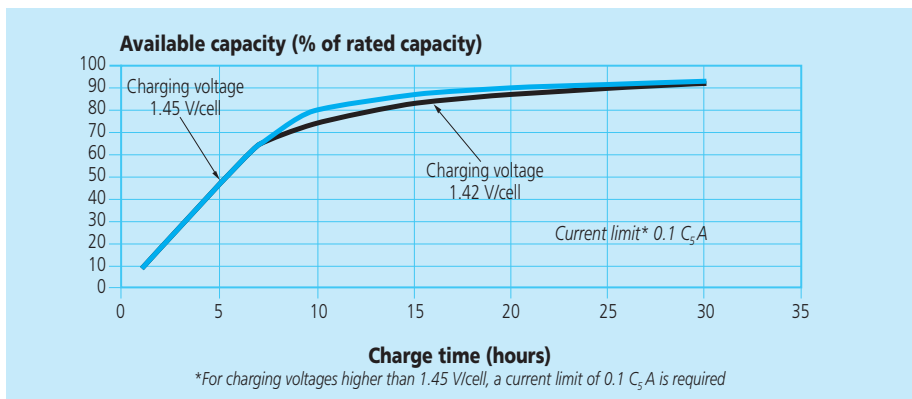

Meeting international standards

Alcad batteries are manufactured under a strict ISO 9001 regime. Highest quality materials and rigorous quality checking procedures ensure all relevant international standards are met, including IEC 60623 and 62259.

Vantage has been developed in line with the safety requirements of EN 50272-2, and components used (such as insulated cable connectors and end lug covers) are defined to ensure high protection against electric shocks (IP2 level).

Further technical data are available on request.

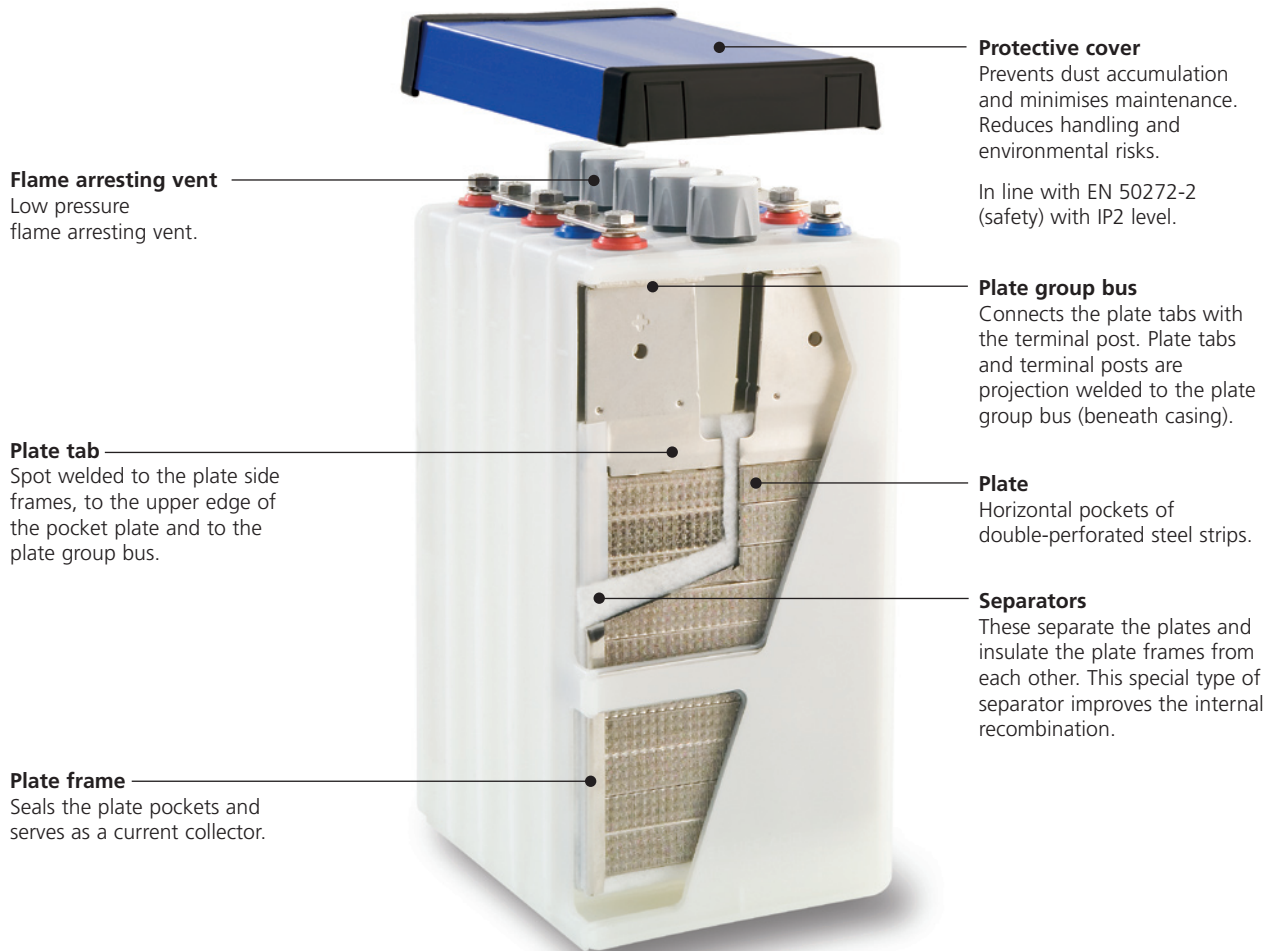

For serial connection of blocks on racks or on shelves, always use blocks with an even number of cells. This gives short, straight interblock connectors. When a block with an odd number of cells is necessary, it should be placed at the end of a cell row.

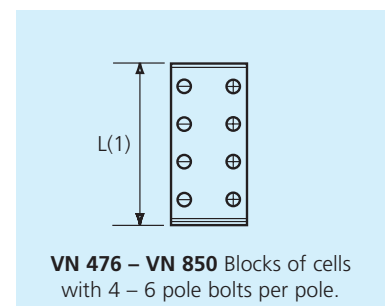
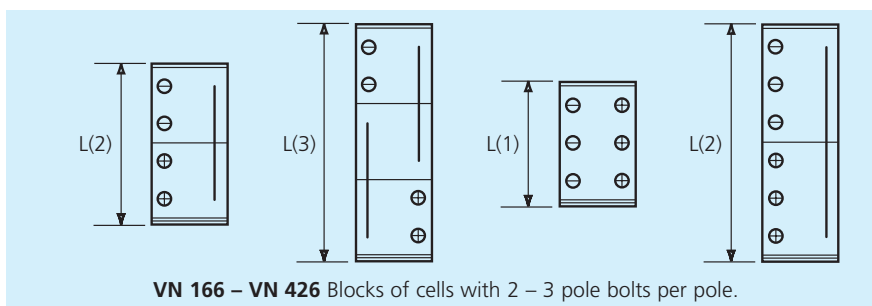
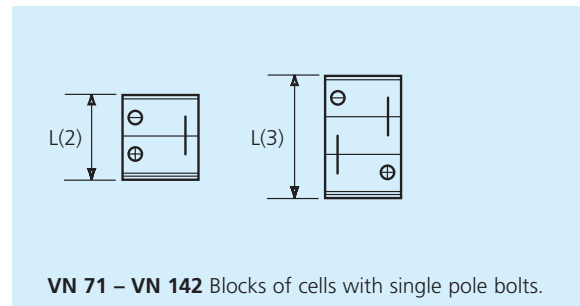
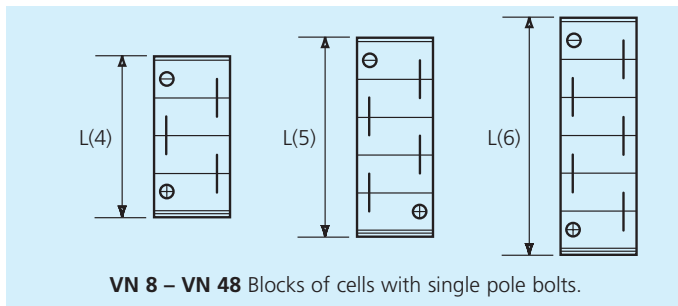

Capacity and dimensions

Vantage

Vantage type	Capacity at the 5 h rate (Ah)	Nominal Voltage (V)	Overall height (with protective cover)		Width		Length per block		Approx. weight per block	
			H (mm)	H (in.)	W (mm)	W (in.)	L (mm)	L (in.)	(kg)	(lb)
VN 8-4	8	4.8	270	10.63	123	4.84	133	5.24	5.5	12.1
VN 8-5	8	6	270	10.63	123	4.84	162	6.38	6.8	15.0
VN 8-6	8	7.2	270	10.63	123	4.84	191	7.52	8.1	17.9
VN 16-4	16	4.8	270	10.63	123	4.84	133	5.24	6.1	13.4
VN 16-5	16	6	270	10.63	123	4.84	162	6.38	7.6	16.8
VN 16-6	16	7.2	270	10.63	123	4.84	191	7.52	9.1	20.1
VN 24-4	24	4.8	270	10.63	123	4.84	153	6.03	7.3	16.1
VN 24-5	24	6	270	10.63	123	4.84	187	7.36	9.0	19.9
VN 24-6	24	7.2	270	10.63	123	4.84	221	8.70	10.7	23.6
VN 32-4	32	4.8	270	10.63	123	4.84	201	7.91	10.0	22.1
VN 32-5	32	6	270	10.63	123	4.84	247	9.72	12.4	27.3
VN 32-6	32	7.2	270	10.63	123	4.84	293	11.54	14.8	32.6
VN 40-4	40	4.8	270	10.63	123	4.84	249	9.80	12.3	27.1
VN 40-5	40	6	270	10.63	123	4.84	307	12.08	15.3	33.7
VN 40-6	40	7.2	270	10.63	123	4.84	365	14.37	18.3	40.4
VN 48-4	48	4.8	270	10.63	123	4.84	249	9.80	13.7	30.2
VN 48-5	48	6	270	10.63	123	4.84	307	12.08	17.0	37.5
VN 48-6	48	7.2	270	10.63	123	4.84	365	14.37	20.3	44.8
VN 71-2	71	2.4	421	16.57	195	7.68	97	3.82	10.2	22.5
VN 71-3	71	3.6	421	16.57	195	7.68	133	5.24	14.6	32.2
VN 95-2	95	2.4	421	16.57	195	7.68	112	4.41	13.3	29.3
VN 95-3	95	3.6	421	16.57	195	7.68	155	6.10	19.4	42.8
VN 119-2	119	2.4	421	16.57	195	7.68	133	5.24	15.8	34.8
VN 119-3	119	3.6	421	16.57	195	7.68	187	7.36	23.2	51.2
VN 142-2	142	2.4	421	16.57	195	7.68	145	5.71	18.5	40.8
VN 142-3	142	3.6	421	16.57	195	7.68	205	8.07	27.0	59.5
VN 166-2	166	2.4	421	16.57	195	7.68	184	7.24	22.8	50.3
VN 166-3	166	3.6	421	16.57	195	7.68	263	10.35	33.6	74.1
VN 190-2	190	2.4	421	16.57	195	7.68	198	7.80	25.5	56.2
VN 190-3	190	3.6	421	16.57	195	7.68	284	11.18	37.7	83.1
VN 238-2	238	2.4	421	16.57	195	7.68	241	9.49	30.5	67.3
VN 238-3	238	3.6	421	16.57	195	7.68	349	13.74	45.3	99.9
VN 285-2	285	2.4	421	16.57	195	7.68	265	10.43	33.6	74.1
VN 285-3	285	3.6	421	16.57	195	7.68	385	15.16	49.9	110
VN 357-1	357	1.2	421	16.57	195	7.68	187	7.36	23.2	51.2
VN 357-2	357	2.4	421	16.57	195	7.68	349	13.74	45.0	99.2
VN 426-1	426	1.2	421	16.57	195	7.68	205	8.07	27.0	59.5
VN 476-1	476	1.2	421	16.57	195	7.68	241	9.49	30.2	66.5
VN 570-1	570	1.2	405	15.94	195	7.68	265	10.43	34.5	76.0
VN 600-1	600	1.2	405	15.94	195	7.68	295	11.61	37.4	82.4
VN 710-1	710	1.2	405	15.94	195	7.68	325	12.80	42.0	92.5
VN 850-1	850	1.2	405	15.94	195	7.68	385	15.16	49.5	109.1

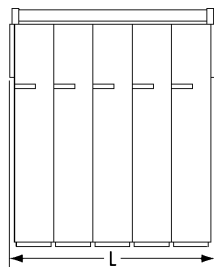
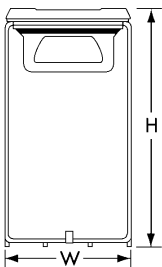

Cell connection bolt per pole:

VN 8-4 to VN 48-6:	M6
VN 71-2 to VN 95-3:	M8
VN 119-2 to VN 142-3:	M10
VN 166-2 to VN 190-3:	2 x M8
VN 238-2 to VN 285-3:	2 x M10
VN 357-1 to VN 426-1:	3 x M10
VN 476-1 to VN 570:	4 x M10
VN 600 to VN 710:	5 x M10
VN 850:	6 x M10

Performance after prolonged float charge of fully charged cell

Available amperes at +20°C ± 5°C (+68°F ± 9°F)

Final voltage: 1.00 V/cell

Cell type	C _s Ah	HOURS					MINUTES						SECONDS			
		10 h	8 h	5 h	3 h	2 h	90 min	60 min	45 min	30 min	10 min	5 min	60 s	30 s	10 s	1 s
VN 8	8	0.8	1.0	1.6	2.6	3.8	4.7	6.1	6.9	8.0	10.9	12.2	16.2	17.9	21.1	25.5
VN 16	16	1.6	2.0	3.2	5.1	7.6	9.4	12.2	13.8	16.0	21.8	24.5	32.3	35.7	42.2	51.0
VN 24	24	2.4	3.0	4.8	7.7	11.3	14.1	18.4	20.7	24.0	32.6	36.7	48.5	53.6	63.2	76.5
VN 32	32	3.2	4.0	6.4	10.3	15.1	18.8	24.5	27.5	32.0	43.5	49.0	64.6	71.4	84.3	102
VN 40	40	4.0	5.1	8.0	12.8	18.9	23.5	30.6	34.4	40.0	54.4	61.2	80.8	89.3	105	128
VN 48	48	4.9	6.1	9.6	15.4	22.7	28.2	36.7	41.3	47.9	65.3	73.4	96.9	107	126	153
VN 71	71	7.2	9.0	14.2	23.2	33.9	41.8	54.3	61.4	70.8	94.0	100.3	123	134	153	179
VN 95	95	9.7	12.0	19.0	31.1	45.3	55.9	72.6	82.2	94.7	126	134	165	180	205	239
VN 119	119	12.1	15.0	23.8	38.9	56.8	70.0	91.0	103	119	157	168	207	225	256	299
VN 142	142	14.5	17.9	28.4	46.4	67.8	83.5	109	123	142	188	201	247	269	306	357
VN 166	166	16.9	21.0	33.2	54.3	79.2	97.6	127	144	165	220	235	288	314	358	417
VN 190	190	19.4	24.0	37.9	62.1	90.7	112	145	164	189	251	268	330	359	409	478
VN 238	238	24.3	30.0	47.5	77.8	114	140	182	206	237	315	336	413	450	513	598
VN 285	285	29.1	36.0	56.9	93.2	136	168	218	247	284	377	403	495	539	614	717
VN 357	357	36.3	45.0	71.4	117	170	210	273	309	357	471	504	621	675	768	897
VN 426	426	43.5	53.7	85.2	139	203	251	327	369	426	564	603	741	807	918	1071
VN 476	476	48.6	60.0	95.0	156	228	280	364	412	474	630	672	826	900	1026	1196
VN 570	570	58.2	71.8	114	187	273	335	436	493	568	754	805	989	1078	1229	1432
VN 600	600	61.3	75.6	120	197	287	353	459	519	597	794	847	1041	1134	1293	1508
VN 710	710	72.5	89.5	142	233	340	418	543	615	707	940	1002	1232	1342	1530	1784
VN 850	850	86.8	107	170	279	407	500	650	736	846	1125	1200	1475	1607	1832	2136

Available amperes at +20°C ± 5°C (+68°F ± 9°F)

Final voltage: 1.05 V/cell

Cell type	C _s Ah	HOURS					MINUTES						SECONDS			
		10 h	8 h	5 h	3 h	2 h	90 min	60 min	45 min	30 min	10 min	5 min	60 s	30 s	10 s	1 s
VN 8	8	0.8	1.0	1.6	2.5	3.5	4.3	5.4	5.9	6.5	8.5	9.9	13.3	15.0	17.5	22.1
VN 16	16	1.6	2.0	3.2	5.1	7.1	8.7	10.9	11.8	12.9	17.0	19.7	26.5	29.9	35.0	44.2
VN 24	24	2.4	3.0	4.7	7.6	10.6	13.0	16.3	17.7	19.4	25.5	29.6	39.8	44.9	52.5	66.3
VN 32	32	3.2	4.0	6.3	10.1	14.2	17.3	21.8	23.7	25.8	34.0	39.4	53.0	59.8	70.0	88.4
VN 40	40	4.1	5.0	7.9	12.7	17.7	21.7	27.2	29.6	32.3	42.5	49.3	66.3	74.8	87.6	111
VN 48	48	4.9	6.0	9.5	15.2	21.2	26.0	32.6	35.5	38.8	51.0	59.2	79.6	89.8	105	133
VN 71	71	7.2	8.9	14.1	22.8	32.6	38.3	46.3	51.6	59.6	74.8	83.3	106	114	128	149
VN 95	95	9.6	11.9	18.9	30.5	43.6	51.2	61.9	69.1	79.8	100	111	142	152	171	199
VN 119	119	12.0	14.9	23.6	38.2	54.6	64.2	77.6	86.5	100	125	140	178	191	214	249
VN 142	142	14.3	17.7	28.2	45.6	65.1	76.6	92.6	103	119	150	167	213	228	255	298
VN 166	166	16.7	20.7	33.0	53.3	76.1	89.5	108	121	139	175	195	248	266	298	348
VN 190	190	19.2	23.7	37.7	61.0	87.1	102	124	138	160	200	223	284	305	341	398
VN 238	238	24.0	29.7	47.2	76.4	109	128	155	173	200	251	279	356	382	427	499
VN 285	285	28.7	35.6	56.6	91.5	131	154	186	207	239	300	334	426	457	512	597
VN 357	357	36.0	44.7	70.8	115	164	193	233	260	300	375	420	534	573	642	747
VN 426	426	42.9	53.1	84.6	137	195	230	278	309	357	450	501	639	684	765	894
VN 476	476	48.0	59.4	94.4	153	218	256	310	346	400	502	558	712	764	854	998
VN 570	570	57.5	71.1	113	183	261	307	371	414	479	601	668	853	915	1023	1195
VN 600	600	60.5	74.9	119	193	275	323	391	436	504	633	703	897	963	1076	1258
VN 710	710	71.6	88.6	141	228	325	382	462	516	597	749	832	1062	1140	1274	1489
VN 850	850	85.7	106	169	273	389	457	554	618	714	896	996	1271	1364	1525	1782

Performance after prolonged float charge of fully charged cell

Available amperes at +20°C ± 5°C (+68°F ± 9°F)

Final voltage: 1.10 V/cell

Cell type	C _s Ah	HOURS					MINUTES					SECONDS				
		10 h	8 h	5 h	3 h	2 h	90 min	60 min	45 min	30 min	10 min	5 min	60 s	30 s	10 s	1 s
VN 8	8	0.8	1.0	1.6	2.3	3.0	3.5	4.4	4.8	5.3	6.5	7.6	10.5	11.9	14.1	17.9
VN 16	16	1.6	2.0	3.1	4.6	5.9	7.0	8.8	9.5	10.5	13.0	15.1	21.1	23.8	28.2	35.7
VN 24	24	2.4	3.0	4.7	6.8	8.9	10.5	13.3	14.3	15.8	19.4	22.7	31.6	35.7	42.3	53.6
VN 32	32	3.2	4.0	6.2	9.1	11.9	14.0	17.7	19.0	21.1	25.9	30.3	42.2	47.6	56.4	71.4
VN 40	40	4.0	5.0	7.8	11.4	14.9	17.6	22.1	23.8	26.4	32.4	37.8	52.7	59.5	70.6	89.3
VN 48	48	4.8	6.0	9.3	13.7	17.8	21.1	26.5	28.6	31.6	38.9	45.4	63.2	71.4	84.7	107
VN 71	71	7.1	8.8	13.8	21.5	29.0	33.5	39.2	42.7	47.2	58.3	64.6	83.3	92.7	102	111
VN 95	95	9.5	11.8	18.4	28.8	38.9	44.8	52.4	57.2	63.1	78.0	86.4	111	124	136	149
VN 119	119	11.9	14.7	23.1	36.0	48.7	56.1	65.6	71.6	79.1	97.7	108	140	155	171	187
VN 142	142	14.2	17.6	27.5	43.0	58.1	67.0	78.3	85.4	94.3	117	129	167	185	204	223
VN 166	166	16.6	20.5	32.2	50.3	67.9	78.3	91.6	100	110	136	151	195	217	238	260
VN 190	190	19.0	23.5	36.9	57.5	77.7	89.6	105	114	126	156	173	223	248	273	298
VN 238	238	23.8	29.5	46.2	72.1	97.3	112	131	143	158	195	217	279	311	342	373
VN 285	285	28.5	35.3	55.3	86.3	117	134	157	171	189	234	259	334	372	409	447
VN 357	357	35.7	44.1	69.3	108	146	168	197	215	237	293	324	420	465	513	561
VN 426	426	42.6	52.8	82.5	129	174	201	235	256	283	351	387	501	555	612	669
VN 476	476	47.6	59.0	92.4	144	195	224	262	286	316	390	434	558	622	684	746
VN 570	570	57.0	70.7	111	172	234	268	314	342	378	467	520	668	745	819	893
VN 600	600	60.0	74.4	116	182	246	282	330	361	398	492	547	703	784	862	940
VN 710	710	71.0	88.0	138	215	291	334	391	427	471	582	647	832	928	1020	1113
VN 850	850	85.0	105	165	257	348	400	468	511	564	696	775	996	1111	1221	1332

Available amperes at +20°C ± 5°C (+68°F ± 9°F)

Final voltage: 1.14 V/cell

Cell type	C _s Ah	HOURS					MINUTES					SECONDS				
		10 h	8 h	5 h	3 h	2 h	90 min	60 min	45 min	30 min	10 min	5 min	60 s	30 s	10 s	1 s
VN 8	8	0.8	1.0	1.5	2.0	2.4	2.7	3.4	3.7	4.1	5.3	6.2	8.3	9.7	11.6	15.1
VN 16	16	1.6	1.9	3.0	3.9	4.8	5.5	6.7	7.3	8.2	10.5	12.3	16.7	19.4	23.1	30.3
VN 24	24	2.3	2.9	4.6	5.9	7.2	8.2	10.1	11.0	12.2	15.8	18.5	25.0	29.1	34.7	45.4
VN 32	32	3.1	3.8	6.1	7.9	9.6	11.0	13.5	14.6	16.3	21.1	24.6	33.3	38.8	46.2	60.5
VN 40	40	3.9	4.8	7.6	9.9	12.0	13.7	16.8	18.3	20.4	26.4	30.8	41.7	48.5	57.8	75.7
VN 48	48	4.7	5.7	9.1	11.8	14.4	16.5	20.2	21.9	24.5	31.6	36.9	50.0	58.1	69.4	90.8
VN 71	71	6.9	8.5	13.5	19.5	22.0	23.7	27.1	28.5	32.9	41.8	48.5	62.9	68.0	76.5	86.7
VN 95	95	9.2	11.4	18.0	26.1	29.4	31.7	36.3	38.1	44.1	55.9	64.8	84.2	91.0	102	116
VN 119	119	11.6	14.3	22.6	32.7	36.9	39.7	45.5	47.7	55.2	70.0	81.2	105	114	128	145
VN 142	142	13.8	17.1	27.0	39.0	44.0	47.3	54.3	57.0	65.9	83.5	96.9	126	136	153	173
VN 166	166	16.1	19.9	31.5	45.6	51.4	55.3	63.5	66.6	77.0	97.6	113	147	159	179	203
VN 190	190	18.5	22.8	36.1	52.2	58.9	63.3	72.6	76.2	88.1	112	130	168	182	205	232
VN 238	238	23.1	28.6	45.2	65.4	73.7	79.3	91.0	95.5	110	140	162	211	228	256	291
VN 285	285	27.7	34.2	54.1	78.3	88.3	95.0	109	114	132	168	194	252	273	307	348
VN 357	357	34.8	42.9	67.8	98.1	111	119	137	143	166	210	244	315	342	384	435
VN 426	426	41.4	51.3	81.0	117	132	142	163	171	198	251	291	378	408	459	519
VN 476	476	46.2	57.2	90.4	131	147	159	182	191	220	280	324	422	456	512	582
VN 570	570	55.3	68.5	108	157	176	190	218	229	263	335	388	505	546	613	697
VN 600	600	58.2	72.1	114	165	185	200	229	241	277	353	408	532	575	645	734
VN 710	710	68.9	85.3	135	195	219	237	271	285	328	418	483	629	680	764	868
VN 850	850	82.5	102	161	234	263	284	325	341	393	500	579	754	814	914	1039

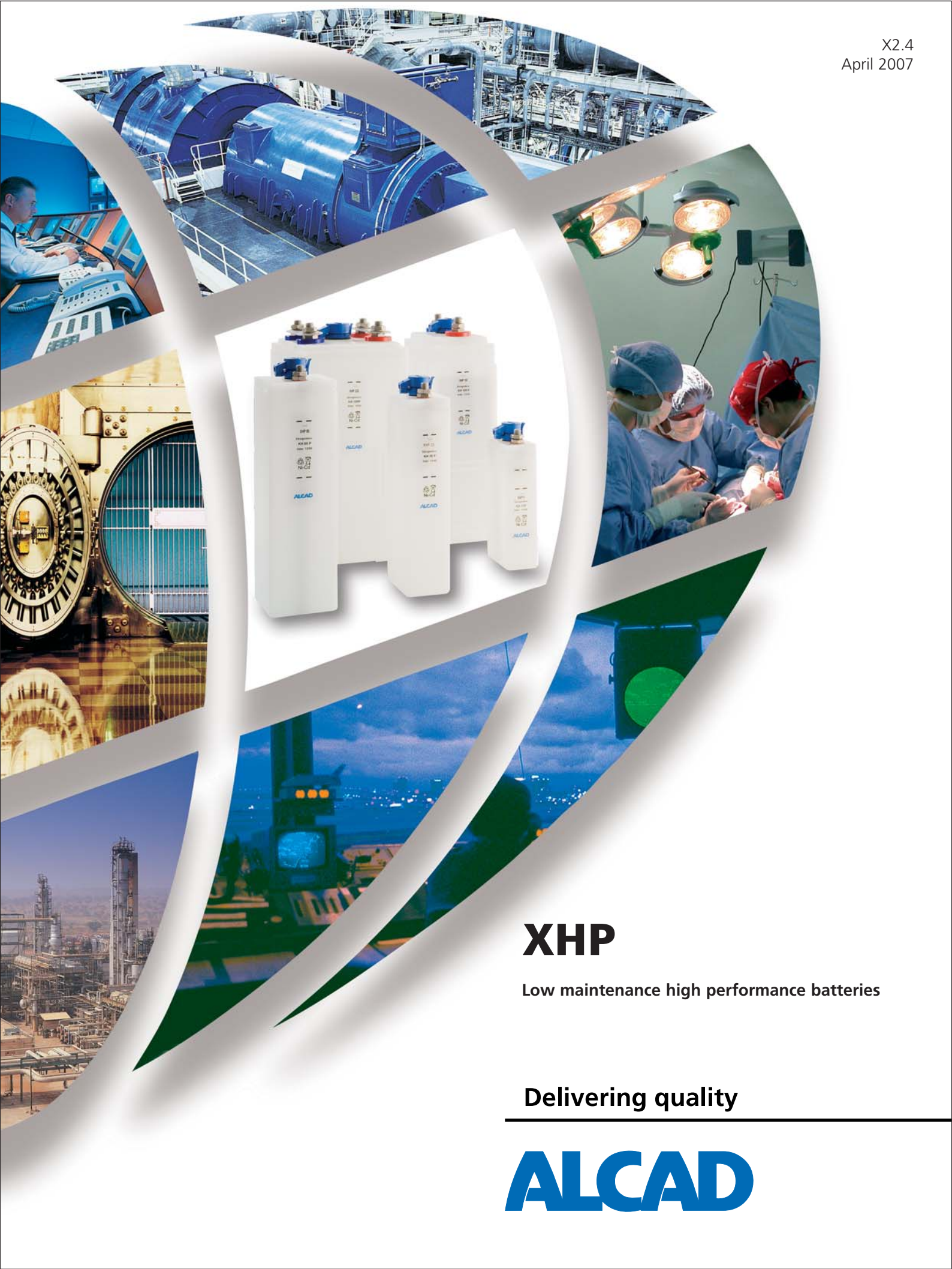

XHP

Low maintenance high performance batteries

Delivering quality

ALCAD

ALCAD XHP Range

Low maintenance, high performance Ni-Cd batteries

Powerful assurance for critical applications

Depend upon XHP where vital UPS, engine starting and emergency back-up duties need guaranteed power in an instant. The built-in reliability of sintered/pbe technology and alkaline electrolyte provides up to 20+ years of cost-effective trouble-free service, requiring virtually no maintenance.

Future-proof construction

XHP's steel superstructure and tough polypropylene casing hold sintered and plastic-bonded electrodes with copious amounts of alkaline electrolyte. As none of these materials are corrosive, XHP confidently outperforms lead acid batteries by several years. On-going maintenance, unexpected downtime and replacement costs are completely eliminated with Ni-Cd. XHP batteries only require topping-up every 10 years after single rate charging.

Predictable cost and long life

Owing to its reliability, unique electrochemistry and sturdy construction, accurately predicting your battery's life-cost is now possible. XHP can easily repay your investment within 3-6 years – well within the lifetime of your application.

Reliable in all conditions

XHP is specified onshore for hospitals, traffic control, power generation and process control, and offshore in oil and gas exploration and other hazardous marine installations, where the implications of main power supply interruption cannot be contemplated.

Generally operating between temperatures of -20°C to $+50^{\circ}\text{C}$ (-4°F to $+122^{\circ}\text{F}$), XHP batteries can tolerate extremes of -50°C to $+70^{\circ}\text{C}$ (-58°F to $+158^{\circ}\text{F}$) for short periods. They can also remain in storage for many years before commissioning without affecting subsequent performance.

Best for engines – perfect for UPS

Electrical abuses such as AC ripple, over-discharging, voltage reversal or high overcharge currents have no effect upon XHP. The battery's plate and separator format make recharging quick and efficient at either single or dual rate.

Delivery of high power within a narrow voltage window perfectly suits XHP for UPS duties. There is no risk of sudden death, and because Ni-Cd batteries do not produce corrosive fumes, they can be installed next to sensitive electronic equipment. Even when partially discharged XHP is capable of providing repeated high currents up to 20 times its nominal capacity to make short work of starting your diesel engine or gas turbine.

Battery sizing made easy

An XHP battery can be designed to exactly match your installation criteria. With BattSize sizing software, calculations are quick and easy. Engineers are always available when you require additional expert advice.

Original equipment or replacement

From a broad range of sizes, weights and performances available, XHP can perfectly meet your requirement for guaranteed power.

Setting standards worldwide

XHP batteries satisfy all major electrical industry standards and are approved for operation on board ships and offshore installations.

Alcad recycle

Alcad also recycle old batteries as part of their responsibility to safeguard the environment.



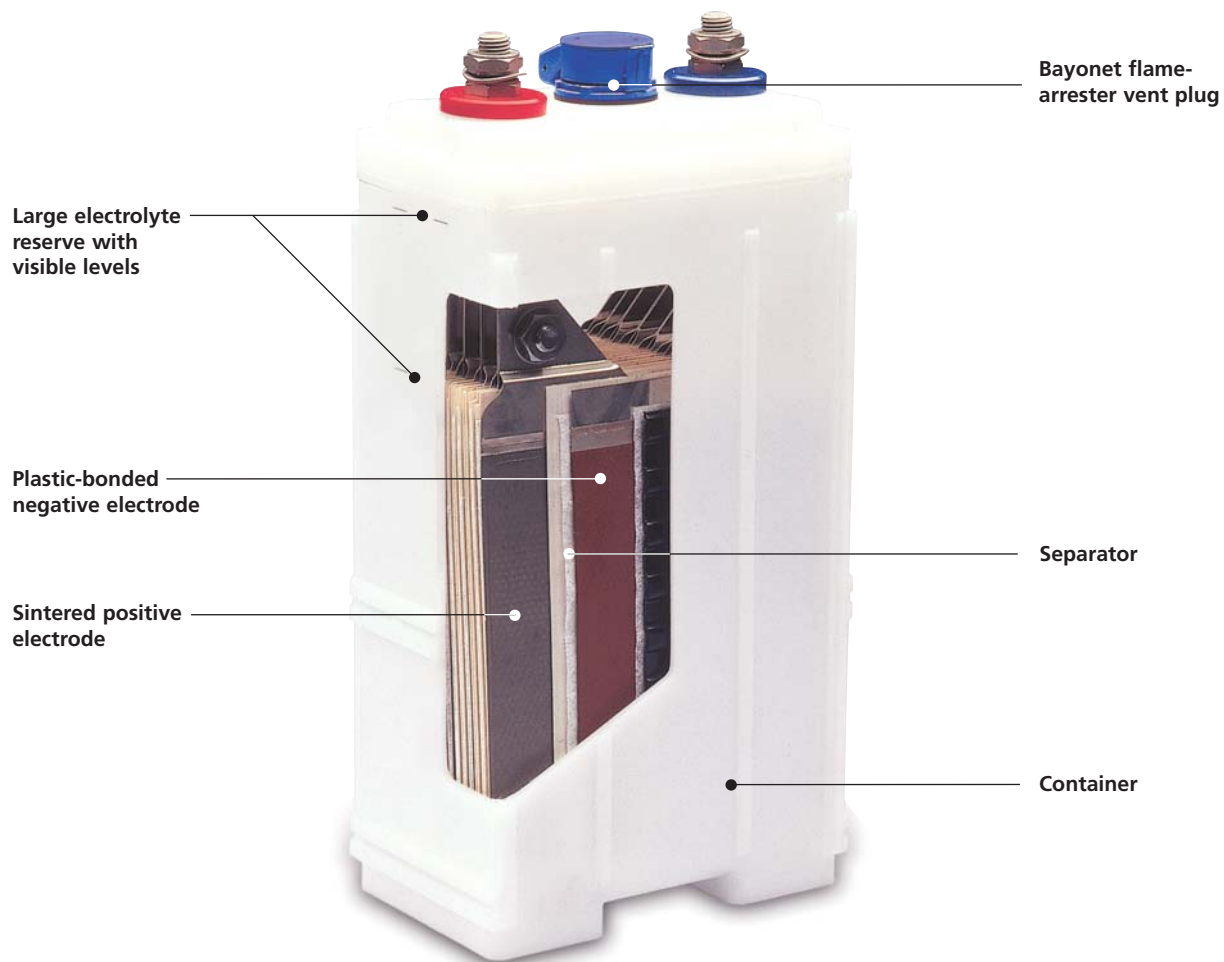

Rapid charging characteristics (+20°C ± 5°C / +68°F ± 9°F)

XHP can be charged by all normal methods:

- Taper
- Constant current
- Constant voltage
- Pulse

The cells continue to operate satisfactorily in any state of charge. For operating conditions other than fully charged, consult Alcad.

Capacity

The rated capacity (C_5) of a cell is the capacity available in ampere-hours (Ah) at the 5 hour discharge rate to an end voltage of 1.00 V/cell.

Nominal discharge voltage

The nominal discharge voltage is 1.2 V/cell.

Constant current charging

Standard charge $0.2 \times C_5$ amperes for 8 hours.

Constant voltage charging

No current limit is necessary.

With boost

Maintenance float voltage:
1.40 ± 0.01 V

Boost voltage range:
1.45 V ± 0.01 V

Without boost

Float voltage:
1.41 V ± 0.01 V

These voltages are applicable from +20°C to +25°C (+68°F to +77°F)

Cell data

D.C. internal resistance:
 $40 \times 1/C_5 \text{ m}\Omega$

Short circuit current:
1.8 x cell discharge current
at 1 s to 0.65 V

XHP type	Capacity at the 5hr rate (Ah)	Length per cell		Width per cell		Overall height		Approx. weight per cell		Volume of liquid electrolyte above plates (cc)
		(mm)	L (in)	(mm)	W (in)	(mm)	H (in)	(kg)	(lb)	
XHP 11	11	46.5	1.8	86	3.4	196	7.2	1.0	2.2	66
XHP 16	16	46.5	1.8	86	3.4	276	10.9	1.5	3.5	160
XHP 21	21	46.5	1.8	86	3.4	276	10.9	1.6	3.5	160
XHP 24	24	46.5	1.8	86	3.4	276	10.9	1.7	3.8	160
XHP 28	28	61	2.4	86	3.4	276	10.9	2.0	4.4	215
XHP 36	36	86	3.4	86	3.4	276	10.9	2.7	6.0	325
XHP 45	45	86	3.4	86	3.4	276	10.9	2.9	6.4	315
XHP 52	52	86	3.4	86	3.4	276	10.9	2.9	6.4	315
XHP 60	60	86	3.4	86	3.4	306	12.1	3.4	7.5	405
XHP 70	70	86	3.4	86	3.4	306	12.1	3.5	7.5	405
XHP 80	80	86	3.4	86	3.4	306	12.1	3.5	7.5	390
XHP 90	90	78	3.1	166	6.5	339	13.4	5.8	12.8	750
XHP 100	100	78	3.1	166	6.5	339	13.4	6.1	13.5	735
XHP 115	115	78	3.1	166	6.5	339	13.4	6.3	13.9	720
XHP 130	130	87	3.4	166	6.5	339	13.4	7.0	15.4	815
XHP 150	150	103	4.1	166	6.5	339	13.4	8.2	18.1	990
XHP 170	170	117	4.6	166	6.5	339	13.4	9.7	21.6	1135
XHP 190	190	117	4.6	166	6.5	339	13.4	10.0	22.3	1115
XHP 220	220	198	7.9	166	6.5	339	13.4	14.7	32.4	2155
XHP 250	250	198	7.9	166	6.5	339	13.4	15.3	33.7	2120
XHP 280	280	198	7.9	166	6.5	339	13.4	15.8	34.6	2080
XHP 300	300	198	7.9	166	6.5	339	13.4	16.1	35.5	2060
XHP 320	320	198	7.9	166	6.5	339	13.4	16.5	36.2	2030

Alcad XHP batteries fulfil all requirements specified by IEC publication 60623. Flame retardant (F) option available. Please add 1.5% to dimensions.

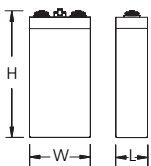

Terminals

XHP 11 - XHP 80	M10
XHP 90 - XHP 150	M12
XHP 170 - XHP 320	2 x M12

Data for stationary applications

XHP

Performance after prolonged float charge of fully charged cells

Available amperes at +20°C ± 5°C/+68°F ± 9°F

Final voltage: 1.00 V/cell

XHP type	C _s Ah	HOURS				MINUTES								SECONDS		
		8 h	5 h	3 h	2 h	90 min	60 min	30 min	20 min	15 min	10 min	5 min	1 min	30 s	5 s	1 s
XHP 11	11	1.4	2.2	3.6	5.4	7.2	10.6	20.6	29.6	35.9	45.3	52.8	66.2	73.1	90.1	99.8
XHP 16	16	2.0	3.2	5.3	7.9	10.4	15.4	30.0	43.0	52.3	65.8	76.8	96.4	107	132	145
XHP 21	21	2.7	4.2	7.0	10.4	13.7	20.3	39.4	56.5	68.6	86.4	101	127	140	173	191
XHP 24	24	3.0	4.8	8.0	11.8	15.7	23.1	45.0	64.6	78.4	98.8	115	145	160	197	218
XHP 28	28	3.6	5.6	9.3	13.8	18.3	27.0	52.5	75.3	91.4	115	135	169	187	230	254
XHP 36	36	4.6	7.2	11.9	17.8	23.5	34.7	67.5	96.8	118	148	173	216	240	295	328
XHP 45	45	5.7	9.0	14.9	22.2	29.4	43.4	84.4	121	147	185	217	271	300	369	410
XHP 52	52	6.6	10.4	17.2	25.6	33.9	50.1	97.5	140	170	214	250	313	346	426	473
XHP 60	60	7.5	12.0	19.9	29.6	39.2	57.9	112	159	190	225	250	308	337	402	443
XHP 70	70	8.8	14.0	23.2	34.5	45.7	67.5	130	186	221	263	292	360	394	469	517
XHP 80	80	10.2	16.0	26.5	39.4	52.2	77.1	149	212	253	300	334	411	449	536	591
XHP 90	90	11.4	18.0	29.8	44.4	58.7	86.8	165	230	268	317	375	511	574	701	754
XHP 100	100	12.7	20.0	33.1	49.3	65.3	96.4	183	255	297	352	417	568	638	779	838
XHP 115	115	14.6	23.0	38.1	56.7	75.1	111	210	293	342	405	479	653	733	896	964
XHP 130	130	16.5	26.0	43.1	64.1	84.9	125	238	332	386	458	542	738	829	1010	1090
XHP 150	150	19.0	30.0	49.7	74.0	97.9	145	274	383	446	528	625	852	957	1170	1260
XHP 170	170	21.6	34.0	56.3	83.8	111	164	311	434	505	599	708	965	1080	1320	1420
XHP 190	190	24.1	38.0	63.0	93.7	124	183	347	485	565	669	791	1080	1210	1480	1590
XHP 220	220	27.9	44.0	72.9	108	143	212	402	561	654	775	916	1250	1400	1710	1840
XHP 250	250	31.7	50.0	82.8	123	163	241	457	638	743	881	1040	1420	1590	1950	2100
XHP 280	280	35.5	56.0	92.8	138	182	270	512	714	832	986	1170	1590	1790	2180	2350
XHP 300	300	38.1	60.0	99.4	147	195	289	548	765	892	1060	1250	1700	1910	2340	2510
XHP 320	320	40.6	64.0	106	157	208	309	585	816	951	1130	1330	1820	2040	2490	2680

Available amperes at +20°C ± 5°C/+68°F ± 9°F

Final voltage: 1.05 V/cell

XHP type	C _s Ah	HOURS				MINUTES								SECONDS		
		8 h	5 h	3 h	2 h	90 min	60 min	30 min	20 min	15 min	10 min	5 min	1 min	30 s	5 s	1 s
XHP 11	11	1.4	2.2	3.6	5.4	7.1	10.5	20.2	27.5	32.7	38.3	43.9	55.3	62.3	76.9	85.6
XHP 16	16	2.0	3.2	5.3	7.8	10.3	15.2	29.4	40.0	47.5	55.7	63.9	80.4	90.5	112	125
XHP 21	21	2.6	4.2	6.9	10.3	13.5	20.0	38.5	52.5	62.4	73.1	83.9	106	119	147	164
XHP 24	24	3.0	4.8	7.9	11.8	15.5	22.9	44.0	60.0	71.3	83.6	95.9	121	136	168	187
XHP 28	28	3.5	5.6	9.2	13.7	18.1	26.7	51.4	70.0	83.2	97.5	112	141	159	196	218
XHP 36	36	4.5	7.1	11.8	17.6	23.2	34.3	66.1	90.0	107	125	144	181	204	252	280
XHP 45	45	5.7	8.9	14.8	22.1	29.0	42.9	82.6	113	134	157	180	226	255	315	350
XHP 52	52	6.5	10.3	17.1	25.5	33.5	49.5	95.4	130	154	181	208	261	294	364	405
XHP 60	60	7.5	11.9	19.7	29.4	38.7	57.1	109	145	168	187	206	257	285	342	373
XHP 70	70	8.8	13.9	23.0	34.3	45.2	66.7	127	169	196	218	240	300	333	399	436
XHP 80	80	10.1	15.9	26.3	39.2	51.6	76.2	145	193	223	249	274	343	380	456	498
XHP 90	90	11.3	17.9	29.6	44.1	58.1	85.7	157	202	230	262	307	435	490	600	650
XHP 100	100	12.6	19.8	32.9	49.0	64.5	95.2	175	225	256	291	341	483	544	667	723
XHP 115	115	14.5	22.8	37.8	56.4	74.2	110	201	259	294	335	393	556	626	767	831
XHP 130	130	16.4	25.8	42.8	63.7	83.9	124	227	292	332	379	444	628	708	867	940
XHP 150	150	18.9	29.8	49.3	73.5	96.8	143	262	337	383	437	512	725	817	1000	1080
XHP 170	170	21.4	33.7	55.9	83.3	110	162	297	382	434	495	580	821	925	1130	1230
XHP 190	190	23.9	37.7	62.5	93.1	123	181	332	427	485	553	648	918	1030	1270	1370
XHP 220	220	27.7	43.7	72.4	108	142	210	384	495	562	641	751	1060	1200	1470	1590
XHP 250	250	31.4	49.6	82.2	123	161	238	436	562	639	728	853	1200	1360	1670	1810
XHP 280	280	35.2	55.6	92.1	137	181	267	489	630	715	816	956	1350	1520	1870	2020
XHP 300	300	37.7	59.5	98.7	147	194	286	524	675	767	874	1020	1450	1630	2000	2170
XHP 320	320	40.3	63.5	105	157	207	305	559	719	818	932	1090	1550	1740	2130	2310

Performance after prolonged float charge of fully charged cells

Available amperes at +20°C ± 5°C/+68°F ± 9°F

Final voltage: 1.10 V/cell

XHP type	C ₅ Ah	HOURS				MINUTES								SECONDS		
		8 h	5 h	3 h	2 h	90 min	60 min	30 min	20 min	15 min	10 min	5 min	1 min	30 s	5 s	1 s
XHP 11	11	1.4	2.2	3.5	5.3	6.9	9.9	17.6	22.5	25.8	29.8	34.9	45.1	51.6	64.0	71.3
XHP 16	16	2.0	3.1	5.2	7.6	10.0	14.4	25.5	32.8	37.5	43.3	50.7	65.6	75.1	93.1	104
XHP 21	21	2.6	4.1	6.8	10.0	13.2	18.9	33.5	43.0	49.2	56.8	66.6	86.0	98.6	122	136
XHP 24	24	3.0	4.7	7.7	11.5	15.0	21.6	38.3	49.1	56.2	65.0	76.1	98.3	113	140	156
XHP 28	28	3.5	5.5	9.0	13.4	17.6	25.2	44.7	57.3	65.6	75.8	88.7	115	131	163	182
XHP 36	36	4.5	7.1	11.6	17.2	22.6	32.4	57.4	73.7	84.3	97.4	114	148	169	210	233
XHP 45	45	5.6	8.8	14.5	21.5	28.2	40.5	71.8	92.1	105	122	143	184	211	262	292
XHP 52	52	6.5	10.2	16.7	24.8	32.6	46.8	83.0	107	122	141	165	213	244	303	337
XHP 60	60	7.5	11.8	19.3	28.6	37.6	54.0	92.6	115	128	142	162	209	234	283	310
XHP 70	70	8.7	13.7	22.5	33.4	43.9	63.0	108	134	150	166	189	244	273	329	362
XHP 80	80	9.9	15.7	25.8	38.2	50.2	72.0	124	153	171	190	216	278	313	376	414
XHP 90	90	11.2	17.6	29.0	43.0	56.4	81.0	127	154	174	200	243	353	409	501	540
XHP 100	100	12.4	19.6	32.2	47.7	62.7	90.0	142	171	193	222	270	393	454	556	600
XHP 115	115	14.3	22.5	37.0	54.9	72.1	104	163	197	222	256	311	451	522	640	690
XHP 130	130	16.1	25.5	41.9	62.1	81.5	117	184	223	251	289	351	510	590	723	780
XHP 150	150	18.6	29.4	48.3	71.6	94.0	135	212	257	290	333	405	589	681	834	900
XHP 170	170	21.1	33.3	54.8	81.1	107	153	241	291	328	378	459	667	772	946	1020
XHP 190	190	23.6	37.3	61.2	90.7	119	171	269	326	367	422	513	746	863	1060	1140
XHP 220	220	27.3	43.1	70.9	105	138	198	311	377	425	489	594	864	999	1220	1320
XHP 250	250	31.1	49.0	80.5	119	157	225	354	428	483	556	676	981	1140	1390	1500
XHP 280	280	34.8	54.9	90.2	134	176	252	396	480	541	622	757	1100	1270	1560	1680
XHP 300	300	37.3	58.8	96.6	143	188	270	425	514	580	667	811	1180	1360	1670	1800
XHP 320	320	39.8	62.7	103	153	201	288	453	549	618	711	865	1260	1450	1780	1920

Available amperes at +20°C ± 5°C/+68°F ± 9°F

Final voltage: 1.14 V/cell

XHP type	C ₅ Ah	HOURS				MINUTES								SECONDS		
		8 h	5 h	3 h	2 h	90 min	60 min	30 min	20 min	15 min	10 min	5 min	1 min	30 s	5 s	1 s
XHP 11	11	1.3	2.1	3.4	5.0	6.4	8.6	15.1	18.4	20.8	23.8	27.6	37.3	43.0	53.9	60.1
XHP 16	16	2.0	3.1	4.9	7.2	9.4	12.5	22.0	26.7	30.3	34.6	40.1	54.3	62.5	78.4	87.5
XHP 21	21	2.6	4.1	6.5	9.5	12.3	16.5	28.9	35.1	39.8	45.4	52.6	71.2	82.1	103	115
XHP 24	24	2.9	4.6	7.4	10.9	14.0	18.8	33.0	40.1	45.4	51.9	60.1	81.4	93.8	118	131
XHP 28	28	3.4	5.4	8.6	12.7	16.4	21.9	38.5	46.8	53.0	60.5	70.1	95.0	109	137	153
XHP 36	36	4.4	6.9	11.1	16.3	21.1	28.2	49.5	60.1	68.2	77.8	90.2	122	141	176	197
XHP 45	45	5.5	8.7	13.9	20.4	26.3	35.3	61.9	75.1	85.2	97.3	113	153	176	221	246
XHP 52	52	6.4	10.0	16.0	23.5	30.4	40.7	71.5	86.8	98.5	112	130	176	203	255	284
XHP 60	60	7.4	11.6	18.5	27.1	35.1	47.0	77.7	91.6	101	112	126	172	194	236	260
XHP 70	70	8.6	13.5	21.6	31.7	40.9	54.8	90.7	107	118	131	147	200	227	276	303
XHP 80	80	9.8	15.4	24.7	36.2	46.8	62.7	104	122	134	150	168	229	259	315	346
XHP 90	90	11.0	17.4	27.8	40.7	52.6	70.5	101	119	135	157	192	294	342	422	464
XHP 100	100	12.3	19.3	30.9	45.2	58.5	78.3	112	133	151	175	213	327	380	469	516
XHP 115	115	14.1	22.2	35.5	52.0	67.3	90.1	128	153	173	201	245	376	437	539	593
XHP 130	130	15.9	25.1	40.1	58.8	76.0	102	145	173	196	227	277	425	494	609	670
XHP 150	150	18.4	29.0	46.3	67.9	87.7	118	168	199	226	262	320	490	569	703	774
XHP 170	170	20.8	32.8	52.5	76.9	99.4	133	190	226	256	297	362	555	645	797	877
XHP 190	190	23.3	36.7	58.6	86.0	111	149	212	252	286	332	405	621	721	890	980
XHP 220	220	27.0	42.5	67.9	99.5	129	172	246	292	331	384	469	719	835	1030	1130
XHP 250	250	30.6	48.3	77.2	113	146	196	279	332	376	436	533	817	949	1170	1290
XHP 280	280	34.3	54.1	86.4	127	164	219	313	372	421	489	596	915	1060	1310	1440
XHP 300	300	36.8	57.9	92.6	136	175	235	335	399	451	523	639	980	1140	1410	1550
XHP 320	320	39.2	61.8	98.8	145	187	251	357	425	482	558	682	1050	1210	1500	1650

Data for engine starting applications

XHP

Performance for fully charged cells by a constant current charge according to IEC 60623 standard

Available amperes at +20°C ± 5°C/+68°F ± 9°F

Final voltage: 0.65 V/cell

XHP type	C ₅ Ah	MINUTES		SECONDS			
		1.5 min	1 min	30 s	15 s	5 s	1 s
XHP 11	11	149	161	177	185	202	225
XHP 16	16	217	234	257	270	294	328
XHP 21	21	285	307	338	354	385	430
XHP 24	24	325	351	386	404	440	492
XHP 28	28	380	410	450	472	514	574
XHP 36	36	488	527	579	607	660	738
XHP 45	45	610	658	724	758	826	922
XHP 52	52	705	761	837	876	954	1070
XHP 60	60	813	878	966	1011	1101	1235
XHP 70	70	949	1024	1127	1179	1284	1440
XHP 80	80	1085	1171	1288	1348	1468	1646
XHP 90	90	1120	1230	1400	1500	1650	1790
XHP 100	100	1240	1370	1560	1660	1830	1990
XHP 115	115	1400	1540	1760	1860	2080	2230
XHP 130	130	1570	1720	1950	2080	2290	2470
XHP 150	150	1820	1990	2250	2400	2640	2850
XHP 170	170	2110	2320	2650	2830	3120	3380
XHP 190	190	2360	2590	2960	3160	3490	3780
XHP 220	220	2680	2950	3360	3560	3990	4270
XHP 250	250	3050	3360	3820	4050	4530	4850
XHP 280	280	3390	3710	4200	4480	4930	5330
XHP 300	300	3630	3970	4500	4800	5290	5710
XHP 320	320	3760	4160	4710	4970	5480	5930

Available amperes at +20°C ± 5°C/+68°F ± 9°F

Final voltage: 0.85 V/cell

XHP type	C ₅ Ah	MINUTES			SECONDS			
		3 min	1.5 min	1 min	30 s	15 s	5 s	1 s
XHP 11	11	95.5	107	115	124	133	148	162
XHP 16	16	139	156	167	181	194	215	235
XHP 21	21	182	205	219	237	254	282	309
XHP 24	24	208	234	250	271	291	323	353
XHP 28	28	243	273	292	316	339	376	412
XHP 36	36	313	351	375	407	436	484	530
XHP 45	45	391	439	469	509	545	605	662
XHP 52	52	451	508	541	588	630	699	765
XHP 60	60	520	586	624	678	727	807	883
XHP 70	70	607	684	728	792	848	941	1030
XHP 80	80	694	782	832	905	969	1075	1177
XHP 90	90	709	826	895	997	1090	1210	1290
XHP 100	100	787	917	994	1110	1210	1340	1430
XHP 115	115	885	1040	1120	1250	1370	1510	1600
XHP 130	130	997	1150	1250	1390	1510	1670	1780
XHP 150	150	1150	1330	1440	1600	1740	1930	2050
XHP 170	170	1340	1560	1690	1880	2050	2280	2430
XHP 190	190	1500	1740	1890	2100	2300	2550	2710
XHP 220	220	1690	1980	2140	2390	2620	2890	3060
XHP 250	250	1920	2250	2430	2720	2980	3290	3470
XHP 280	280	2150	2480	2680	3000	3250	3600	3820
XHP 300	300	2300	2660	2870	3210	3480	3857	4100
XHP 320	320	2390	2760	2990	3330	3640	4000	4270

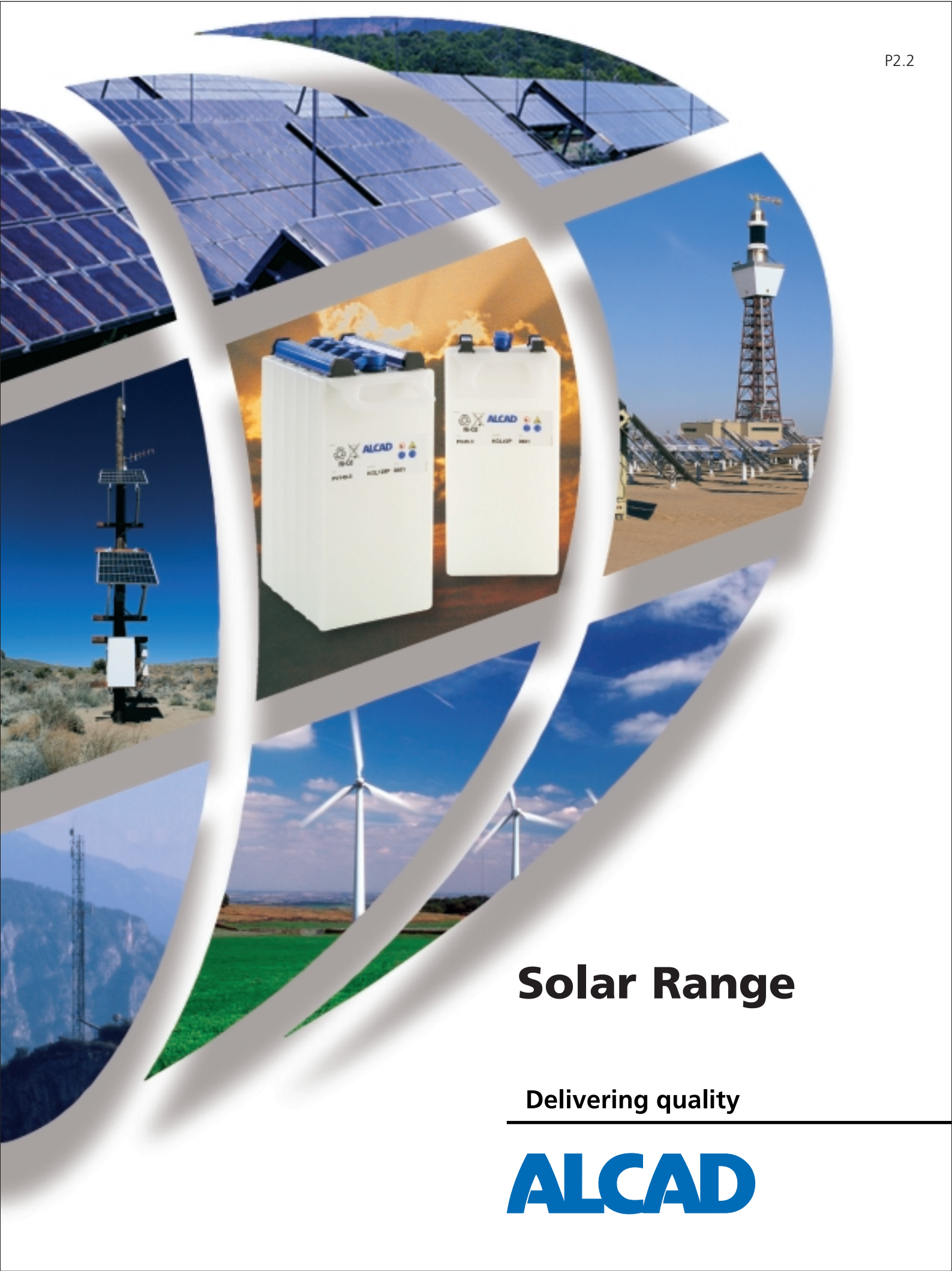

Solar Range

Delivering quality

ALCAD

ALCAD Solar Range

Low maintenance Ni-Cd batteries for stand-alone hybrid systems

Battery systems have a difficult job maintaining reliable service in isolated locations and hostile environments. Demands upon them fluctuate widely and charging depends entirely on irregular and unpredictable weather patterns.

For renewable energy applications

In remote outdoor installations, Alcad Solar is the natural choice for –

- photovoltaic applications
- stand-alone hybrid systems
- renewable energy applications

The solution is Alcad Solar

Alcad Solar storage batteries are purpose built to operate in these conditions. The range provides totally reliable service and very low maintenance which achieves a low life-cycle cost.

Efficient and reliable in tough conditions

Managing complex charging patterns is essential for efficient running of a hybrid system. Alcad Solar will continue to operate at any state of charge.

Over-compensation for unpredictable charging conditions with high charging voltages is unnecessary.

Alcad Solar's typical charging voltage of 1.5 V per cell minimises water-consumption, eliminating unscheduled service calls. The battery reaches a high state of charge without boost or reconditioning charges.

Alcad Solar range Ni-Cd batteries are compatible with all current photovoltaic charge regulators and conventional industrial battery chargers.

Extreme operating temperature

Alcad Solar's robust construction and stable electrochemistry enable it to operate comfortably within a temperature range of -20°C (-4°F) to $+50^{\circ}\text{C}$ ($+122^{\circ}\text{F}$) and will tolerate extremes of -50°C (-58°F) to $+70^{\circ}\text{C}$ ($+158^{\circ}\text{F}$).

For operation in temperatures below -20°C (-4°F), a special, higher density electrolyte is used.

Alcad Solar will deliver 80% capacity for a 120 hour discharge even at -40°C (-40°F).

Long-term low maintenance

The low life-cycle cost Alcad Solar range battery is a reliable long-term investment. It is constructed to resist electrical and physical abuses and therefore requires very low maintenance. In return it will provide totally reliable service at a predictable cost over 20 years.

Additionally, Alcad Solar's reliability reduces demands on expensive diesel generators, thereby contributing to the overall system running cost reduction.

Low life-cycle cost

Long maintenance intervals, Ni-Cd's inherent safety and total reliability combine to make Alcad Solar an exceptionally low life-cycle cost solution.



Solar

Connector cover
In line with
EN 50272-2 (safety)
with IP2 level.

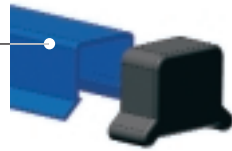

Flame arresting vent
With transport seal protection.

Plate group bus
Connects the plate tabs with the terminal post. Plate tabs and terminal posts are projection welded to the plate group bus.

Plate tab
Spot welded to the plate side frames, to the upper edge of the pocket plate and to the plate group bus.

Handles
Moulded polypropylene handles allow Solar Range batteries to be easily manoeuvred and installed.

Separators
These separate the plates and insulate the plate frames from each other. This special type of separator improves the internal recombination.

Cell container
Made of tough polypropylene.

Plate frame
Seals the plate pockets and serves as a current collector.

Plate
Horizontal pockets of double-perforated steel strips.

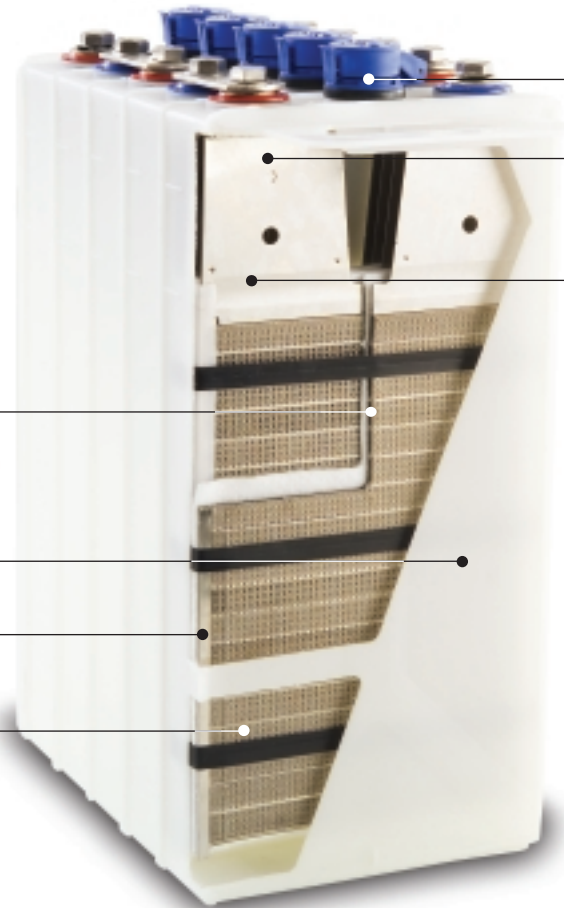

Ni-Cd endures...

Alcad Solar batteries are built around Alcad's proven Ni-Cd pocket plate technology.

Active materials and nickel-plated steel components plus gas recombination technology give maintenance intervals of more than 4 years, reducing operating costs to a minimum.

... where lead acid cannot

Nickel-cadmium technology is inherently safe and resistant to over-, under- and complete discharging. Even at temperatures below -20°C (-4°F), Alcad Solar continues to perform without risk of corrosion or sulphation when cycled at low state of charge.

Alkaline electrolyte will not freeze and remains stable during operation. Lead acid batteries suffer from plate degradation, shortened life and risk of sudden death in similar conditions.

Alcad Solar Ni-Cd continues operating in conditions where lead acid cannot.

Alcad recycle

Alcad recycle old batteries as part of their responsibility to safeguard the environment.

Automated water filling system

Alcad's water filling system is available as an option for Solar Range cell types 185 Ah to 1110 Ah. It enables automatic, fast and accurate topping-up, further extending maintenance intervals.

Meeting international standards

Alcad Solar has been developed in line with the safety requirements of EN 50272-2, and components used (such as insulated cable connectors and end lug covers) are defined to ensure high protection against electric shocks (IP2 level).

Alcad Solar features Alcad's highly efficient internal gas recombination pocket plate technology – meets IEC 62259 – and electrode design optimised for photovoltaic applications.

Solar

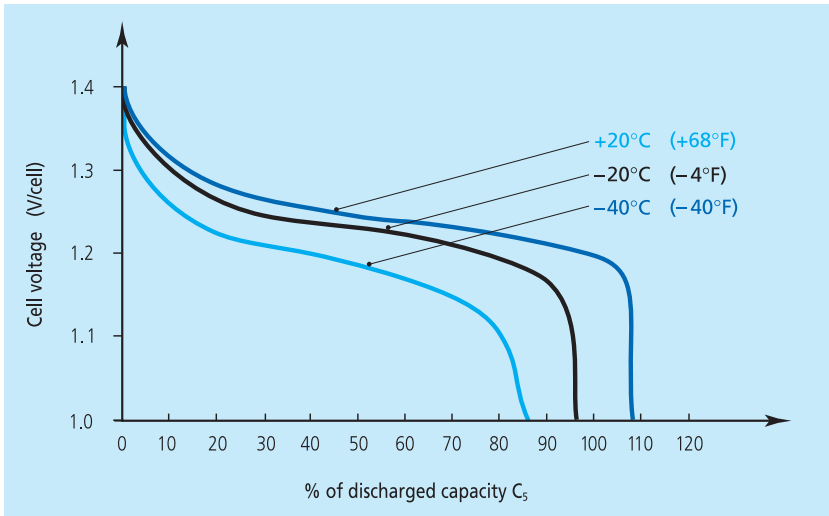

Discharge curves at $\frac{1}{20} C_{120} A$ according to temperature. Battery fully charged.

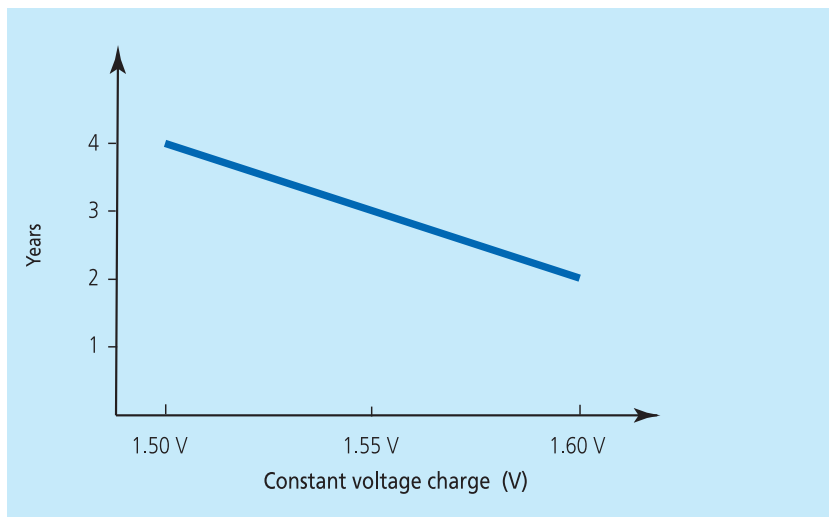

Typical water replenishment +20°C (+68°F)

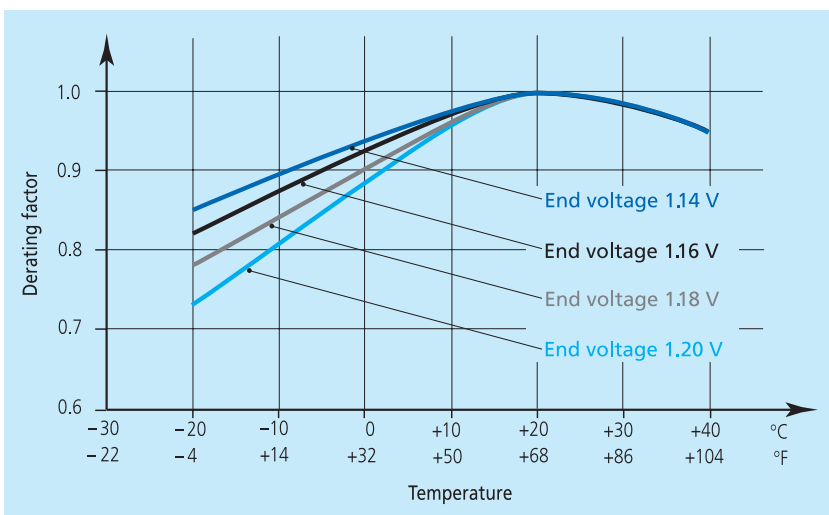

Derating factor according to temperature and end voltage. For typical solar application with 3 or more days back-up time.

Alcad engineers will work with you to calculate the optimum size of battery for your application. They will consider location, operating temperature, anticipated discharge requirements and your system's charging capabilities.

The battery size or Ampere-hours (Ah) required will depend on average load and minimum back-up time or autonomy. Capacity should be sufficient to sustain days of discharge with minimum support from the renewable energy source.

With daily limited time for charging, batteries are not always able to reach full charge. By operating the system so that it approaches, but rarely reaches full capacity, water consumption and maintenance are reduced considerably. By adhering to the recommended charging voltage provided in Table 1, the battery should reach 90% state of charge under average operating conditions.

Initial calculations

Most installations are 12, 24 or 48-volt systems. Typically for these system voltages 9, 18 and 36 cells are used. However, depending on various conditions these numbers may be adjusted by one or two cells.

First, determine the number of cells by establishing –

- Maximum permitted charging voltage
- Daily depth of discharge
- Minimum permitted end voltage

Second, check if “ideal” operating conditions can be established, by consulting Table 1.

Third, check in the cell performance tables the cell type giving the selected current in relation to the end voltage and the back-up time.

Additional sizing considerations

Operating temperature will influence available capacity. While Ni-Cd batteries are less affected by temperature variations than lead acid, it may still be advisable to include derating factors in sizing calculations according to the temperature and end voltage. Refer to derating factor curves on page 4.

Other factors such as design margin, battery aging and future load extension may be included for the battery sizing.

Alcad's optimum sizing method is:

$$\begin{aligned}
 & \text{I load} \\
 & \quad \times \\
 & \text{1/temperature derating factor} \\
 & \quad \times \\
 & \text{1/charge derating factor*} \\
 & \quad \times \\
 & \text{requested design margin} \\
 & \quad = \\
 & \text{current value to select in the} \\
 & \quad \text{performance table}
 \end{aligned}$$

*The typical value is 90% when using the recommended charge voltage

Table 1. Recommended charging voltage

Battery system	12 V	24 V	48 V
Number of cells	9	18	36
5-10% daily depth of discharge	13.5 V	27 V	54 V
10-15% daily depth of discharge	13.95 V	27.9 V	55.8 V
15-25% daily depth of discharge	14.4 V	28.8 V	57.6 V

Solar type	Capacity		Height H		Width W		Length per block L														Approx. weight per cell					
	C ₁₂₀ 120 h 1.0 V	C ₅ 5 h 1.0 V	mm	in	mm	in	1 cell		2 cells		3 cells		4 cells		5 cells		6 cells		8 cells		9 cells		10 cells		kg	lb
	Ah	Ah					mm	in	mm	in	mm	in	mm	in	mm	in	mm	in	mm	in	mm	in	mm	in		
PV 45	45	43	405	15.95	195	7.68					88	3.46	113	4.49	137	5.39	162	6.38	212	8.35	237	9.33	261	10.28	3.2	7.1
PV 90	90	85	405	15.95	195	7.68					121	4.76	157	6.18	192	7.56	228	8.98	300	11.81	336	13.23	371	14.61	4.9	10.8
PV 105	105	100	405	15.95	195	7.68					157	6.18	205	8.07	252	9.92	300	11.81	396	15.59	444	17.48			6.2	13.7
PV 140	140	128	405	15.95	195	7.68					157	6.18	205	8.07	252	9.92	300	11.81	396	15.59					6.7	14.8
PV 185	185	171	405	15.95	195	7.68					193	7.60	253	9.96	312	12.28	372	14.65							8.4	18.5
PV 230	230	213	405	15.95	195	7.68					159	6.26	232	9.13	305	12.01	377	14.84							9.9	21.8
PV 275	275	256	405	15.95	195	7.68					183	7.21	268	10.55	353	13.90	437	17.21							11.5	25.4
PV 320	320	300	405	15.95	195	7.68					228	8.98	336	13.23											15.1	33.3
PV 370	370	341	405	15.95	195	7.68					252	9.92	372	14.65											16.8	37.0
PV 415	415	384	405	15.95	195	7.68	146	5.75	278	10.95															18.3	40.4
PV 460	460	427	405	15.95	195	7.68	159	6.26	304	11.97															19.8	43.7
PV 505	505	469	405	15.95	195	7.68	171	6.73	328	12.91															21.4	47.2
PV 555	555	512	405	15.95	195	7.68	183	7.21	353	13.90															23.0	50.7
PV 645	645	597	405	15.95	195	7.68	219	8.62																	28.2	62.2
PV 735	735	682	405	15.95	195	7.68	244	9.61																	31.3	69.0
PV 830	830	768	405	15.95	195	7.68	268	10.55																	34.5	76.1
PV 920	920	853	405	15.95	195	7.68	304	11.97																	39.6	87.3
PV 1110	1110	1024	405	15.95	195	7.68	352	13.86																	46.0	101

Solar range complies with IEC 62259 standard.



Cell performance

Solar

For fully charged cells after a constant current charge according to IEC 62259 standard.

Available amperes at +20°C ± 5°C (+68°F ± 9°F)

d = days / h = hours

Solar type	End voltage = 1.14 V										End voltage = 1.16 V									
	2 d 48 h	3 d 72 h	4 d 96 h	5 d 120 h	6 d 144 h	7 d 168 h	8 d 192 h	9 d 216 h	10 d 240 h	2 d 48 h	3 d 72 h	4 d 96 h	5 d 120 h	6 d 144 h	7 d 168 h	8 d 192 h	9 d 216 h	10 d 240 h		
PV 45	0.94	0.64	0.48	0.39	0.33	0.28	0.25	0.22	0.20	0.92	0.63	0.47	0.39	0.33	0.28	0.25	0.22	0.20		
PV 90	1.86	1.26	0.95	0.77	0.65	0.56	0.49	0.44	0.40	1.82	1.25	0.94	0.77	0.64	0.56	0.49	0.44	0.40		
PV 105	2.19	1.49	1.11	0.90	0.76	0.66	0.58	0.52	0.47	2.15	1.47	1.10	0.90	0.76	0.65	0.58	0.52	0.47		
PV 140	2.80	1.90	1.43	1.15	0.98	0.85	0.74	0.66	0.60	2.75	1.88	1.41	1.15	0.97	0.84	0.74	0.66	0.60		
PV 185	3.74	2.54	1.91	1.54	1.31	1.13	0.99	0.89	0.80	3.67	2.52	1.89	1.54	1.29	1.12	0.99	0.89	0.80		
PV 230	4.66	3.17	2.37	1.92	1.63	1.41	1.23	1.10	0.99	4.57	3.14	2.35	1.92	1.61	1.39	1.23	1.10	0.99		
PV 275	5.60	3.80	2.85	2.30	1.96	1.69	1.48	1.33	1.19	5.49	3.77	2.83	2.30	1.94	1.68	1.48	1.33	1.19		
PV 320	6.56	4.46	3.34	2.70	2.29	1.98	1.73	1.56	1.40	6.44	4.42	3.31	2.70	2.27	1.96	1.73	1.56	1.40		
PV 370	7.46	5.07	3.80	3.07	2.60	2.25	1.97	1.77	1.59	7.32	5.02	3.77	3.07	2.58	2.23	1.97	1.77	1.59		
PV 415	8.40	5.71	4.28	3.46	2.93	2.54	2.22	1.99	1.79	8.24	5.65	4.24	3.46	2.91	2.51	2.22	1.99	1.79		
PV 460	9.34	6.35	4.76	3.84	3.26	2.82	2.47	2.21	1.99	9.16	6.29	4.71	3.84	3.23	2.80	2.47	2.21	1.99		
PV 505	10.26	6.97	5.23	4.22	3.58	3.10	2.71	2.43	2.19	10.06	6.90	5.18	4.22	3.55	3.07	2.71	2.43	2.19		
PV 555	11.20	7.61	5.71	4.61	3.91	3.38	2.96	2.65	2.39	10.99	7.54	5.65	4.61	3.88	3.35	2.96	2.65	2.39		
PV 645	13.06	8.87	6.65	5.37	4.56	3.94	3.45	3.10	2.79	12.81	8.79	6.59	5.37	4.52	3.91	3.45	3.10	2.79		
PV 735	14.92	10.14	7.60	6.14	5.21	4.51	3.94	3.54	3.18	14.63	10.04	7.53	6.14	5.16	4.47	3.94	3.54	3.18		
PV 830	16.80	11.41	8.56	6.91	5.87	5.07	4.44	3.98	3.58	16.48	11.31	8.48	6.91	5.81	5.03	4.44	3.98	3.58		
PV 920	18.66	12.68	9.51	7.68	6.52	5.64	4.93	4.42	3.98	18.30	12.56	9.42	7.68	6.46	5.59	4.93	4.42	3.98		
PV 1110	22.40	15.52	11.41	9.22	7.82	6.77	5.92	5.31	4.78	21.97	15.08	11.31	9.22	7.75	6.70	5.92	5.31	4.78		

Solar type	End voltage = 1.18 V										End voltage = 1.20 V									
	2 d 48 h	3 d 72 h	4 d 96 h	5 d 120 h	6 d 144 h	7 d 168 h	8 d 192 h	9 d 216 h	10 d 240 h	2 d 48 h	3 d 72 h	4 d 96 h	5 d 120 h	6 d 144 h	7 d 168 h	8 d 192 h	9 d 216 h	10 d 240 h		
PV 45	0.89	0.62	0.47	0.38	0.32	0.28	0.24	0.22	0.20	0.82	0.57	0.43	0.36	0.31	0.27	0.24	0.21	0.19		
PV 90	1.75	1.22	0.93	0.76	0.64	0.55	0.48	0.43	0.39	1.61	1.13	0.86	0.71	0.61	0.53	0.46	0.42	0.38		
PV 105	2.06	1.43	1.09	0.89	0.75	0.65	0.57	0.51	0.46	1.90	1.33	1.01	0.83	0.72	0.62	0.55	0.49	0.44		
PV 140	2.64	1.83	1.40	1.14	0.96	0.83	0.73	0.65	0.59	2.43	1.71	1.29	1.07	0.92	0.79	0.70	0.63	0.57		
PV 185	3.53	2.45	1.87	1.52	1.28	1.11	0.97	0.87	0.78	3.24	2.28	1.73	1.43	1.22	1.06	0.94	0.84	0.76		
PV 230	4.39	3.05	2.33	1.90	1.60	1.38	1.21	1.08	0.98	4.04	2.84	2.15	1.78	1.52	1.32	1.16	1.05	0.94		
PV 275	5.28	3.66	2.80	2.28	1.92	1.66	1.45	1.30	1.17	4.85	3.41	2.59	2.13	1.83	1.58	1.40	1.26	1.13		
PV 320	6.19	4.29	3.28	2.68	2.25	1.95	1.70	1.53	1.38	5.69	4.00	3.03	2.50	2.15	1.86	1.64	1.47	1.33		
PV 370	7.03	4.88	3.73	3.04	2.56	2.21	1.94	1.74	1.56	6.46	4.55	3.45	2.84	2.44	2.11	1.86	1.67	1.51		
PV 415	7.92	5.49	4.20	3.42	2.88	2.49	2.18	1.96	1.76	7.28	5.12	3.88	3.20	2.75	2.38	2.10	1.88	1.70		
PV 460	8.81	6.11	4.67	3.81	3.20	2.77	2.42	2.17	1.96	8.10	5.69	4.31	3.56	3.05	2.64	2.34	2.10	1.89		
PV 505	9.67	6.71	5.13	4.18	3.52	3.04	2.66	2.39	2.15	8.89	6.25	4.74	3.91	3.35	2.90	2.56	2.30	2.07		
PV 555	10.56	7.32	5.60	4.57	3.84	3.32	2.91	2.61	2.35	9.71	6.83	5.17	4.27	3.66	3.17	2.80	2.51	2.26		
PV 645	12.31	8.54	6.53	5.32	4.48	3.87	3.39	3.04	2.74	11.32	7.96	6.03	4.98	4.27	3.70	3.26	2.93	2.64		
PV 735	14.07	9.76	7.46	6.08	5.12	4.42	3.87	3.47	3.13	12.93	9.09	6.89	5.68	4.88	4.22	3.73	3.35	3.01		
PV 830	15.84	10.99	8.40	6.85	5.76	4.98	4.36	3.91	3.52	14.56	10.24	7.76	6.40	5.49	4.75	4.20	3.77	3.39		
PV 920	17.59	12.20	9.33	7.61	6.40	5.53	4.84	4.34	3.91	16.17	11.37	8.62	7.11	6.10	5.28	4.66	4.19	3.77		
PV 1110	21.12	14.65	11.20	9.13	7.68	6.64	5.81	5.21	4.69	19.41	13.65	10.35	8.53	7.32	6.34	5.60	5.03	4.52		

P2.2 Edition : May 2006.

Produced by Arthur Associates.
Map design: C. Patrick Reising/Alamy,
Mark Sykes/Alamy, PhotoDisc.
Data in this document are subject to change without notice and
become contractual only after written confirmation by Alcad.

Alcad Limited



Sweden

Telephone: +46 491 68 100

Facsimile: +46 491 68 110

Alcad Sales Offices



United Kingdom

Telephone: +44 1279 772 555

Facsimile: +44 1279 420 696



Middle East

Telephone: +357 25 871 816

Facsimile: +357 25 343 542



Asia

Telephone: +65 6 7484 486

Facsimile: +65 6 7484 639



USA

Telephone: +1 203 234 8333

Facsimile: +1 203 234 8255

www.alcad.com

Delivering quality

ALCAD

Installation and commissioning kits for industrial Ni-Cd pocket plate batteries

Cells delivered empty



Complete electrolyte preparation kit

Part Number

08-00177-01

Includes...

■ Electrolyte filling kit*

08-00175-01

■ Electrolyte mixing kit*

08-00176-01

*See content below

Electrolyte filling kit

Part Number

08-00175-01

Includes...

■ Thermometer (1 piece)

■ Funnel (1 piece)

■ 2 litre jug (1 piece)



Electrolyte mixing kit

Part Number

08-00176-01

Includes...

■ Mixing tank (1 piece)

■ Tank lid (1 piece)

■ Stirring rod (1 piece)



Note: *photographs in this document are not to scale*



Delivering quality

ALCAD



Cells delivered filled

Complete installation and commissioning kit		Part Number
		08-00174-02
	Includes...	
	■ Protective equipment kit*	08-00132-02
	■ Spanner set kit*	08-00172-02
	■ Electrolyte testing kit*	08-00171-01
	■ Digital multimeter	
*See content below		
Protective equipment kit		Part Number
		08-00132-02
	Includes...	
	■ Gloves (5 pairs)	
	■ Apron (1 piece)	
	■ Goggles (1 pair)	
	■ Eye wash bottle (2 pieces)	
■ Shoe covers (5 pieces)		
Spanner set kit		Part Number
		08-00172-02
	Includes...	
	■ Spanner 8/10 mm (1 piece)	
	■ Spanner 13 mm (1 piece)	
	■ Spanner 16 mm (1 piece)	
	■ Safecoat DW33 1 litre (1 piece) anti-corrosion protection oil	
■ Brush (1 piece)		
Electrolyte testing kit		Part Number
		08-00171-01
	Includes...	
	■ Hydrometer (1 piece)	
	■ Level testing tube (1 piece)	
	■ 1 litre plastic bottle (1 piece)	





Additional accessories: commissioning

	Torque wrench with sockets	Part Number
	<p data-bbox="587 363 1260 395">08-00178-01</p> <p data-bbox="587 410 1260 442">Includes...</p> <ul data-bbox="587 457 1260 538" style="list-style-type: none"> <li data-bbox="587 457 1260 489">• Torque wrench: 8 to 54 N.m (1 piece) <li data-bbox="587 504 1260 538">• Sockets: 10 mm, 13 mm, 16 mm (1 piece of each) 	<p data-bbox="1318 321 1477 353">Part Number</p> <p data-bbox="1318 363 1477 395">08-00178-01</p>
	Plastic bottle with tap	Part Number
	<p data-bbox="587 670 1260 702">08-00179-01</p> <p data-bbox="587 717 1260 749">Includes...</p> <ul data-bbox="587 763 1260 844" style="list-style-type: none"> <li data-bbox="587 763 1260 795">• 25 litre plastic bottle (1 piece) <li data-bbox="587 810 1260 844">• Tap for plastic bottle (1 piece) 	<p data-bbox="1318 627 1477 659">Part Number</p> <p data-bbox="1318 670 1477 702">08-00179-01</p>
	Digital multimeter	Part Number
	<p data-bbox="587 976 1260 1008">01-01925-01</p> <p data-bbox="587 1023 1260 1055">Includes...</p> <ul data-bbox="587 1070 1260 1102" style="list-style-type: none"> <li data-bbox="587 1070 1260 1102">• Digital voltmeter, 1 % accuracy 	<p data-bbox="1318 934 1477 966">Part Number</p> <p data-bbox="1318 976 1477 1008">01-01925-01</p>

Additional accessories: maintenance

	Safecoat DW33	Part Number
	<p data-bbox="587 1466 1260 1498">11-71013-05</p> <p data-bbox="587 1513 1260 1544">Safecoat DW33 (1 litre) anti-corrosion protection oil</p>	<p data-bbox="1318 1423 1477 1455">Part Number</p> <p data-bbox="1318 1466 1477 1498">11-71013-05</p>
	Carbonate testing kit	Part Number
	<p data-bbox="587 1772 1260 1804">08-00009-02</p> <p data-bbox="587 1819 1260 1851">Includes...</p> <ul data-bbox="587 1866 1260 1970" style="list-style-type: none"> <li data-bbox="587 1866 938 1898">• 0.25 litre plastic bottle (1 piece) <li data-bbox="587 1898 938 1930">• Plastic graduated cylinder (2 pieces) <li data-bbox="587 1930 938 1962">• Plastic funnel (1 piece) <li data-bbox="587 1962 938 1993">• Erlenmeyer & rubber plug (2 pieces) <li data-bbox="962 1866 1260 1898">• Filters (20 pieces) <li data-bbox="962 1898 1260 1962">• Plastic bags of BaCl₂ and 2H₂O (10 pieces) <li data-bbox="962 1962 1260 1993">• Standard hydrometer 	<p data-bbox="1318 1730 1477 1761">Part Number</p> <p data-bbox="1318 1772 1477 1804">08-00009-02</p>

Additional accessories: installation

	<p>Cabinet for accessories</p> <p>Wall or floor mounted H 900 mm, W 500 mm, D 450 mm</p> <p><i>Suitable for storage together of ...</i></p> <ul style="list-style-type: none"> • Protective equipment kit • Electrolyte testing kit • Spanner set kit • Digital multimeter • Electrolyte filling kit • Torque wrench • Carbonate testing kit 	<p>Part Number</p> <p>01-02013-01</p>
	<p>Lifting device</p> <ul style="list-style-type: none"> • Capacity 400 kg • Lifting height 1500 mm • Shelf dimensions 650 x 576 mm 	<p>Part Number</p> <p>01-02014-01</p>
	<p>Connecting box</p> <p>Kit with 2 single boxes</p> <ul style="list-style-type: none"> • H 280 mm, W 280 mm, D 140 mm • Weight: 5 kg <p><i>Technical information</i></p> <ul style="list-style-type: none"> • Material: ABS with protection IP 54, • 8 connectivities: Up to 240 mm² - M10 stainless steel screws • Section copper plate: 900 mm² • Max operating temperature: -40°C to +80°C 	<p>Part Number</p> <p>08-00199-01</p>
	<p>Connecting box</p> <p>Kit with 1 double box</p> <ul style="list-style-type: none"> • H 280 mm, W 380 mm, D 140 mm • Weight: 7 kg <p><i>Technical information</i></p> <ul style="list-style-type: none"> • Material: ABS with protection IP 54 • 2 x 5 connectivities: Up to 240 mm² - M10 stainless steel screws • Section copper plate: 2 x 600 mm² • Max operating temperature: -40°C to +80°C 	<p>Part Number</p> <p>08-00199-02</p>

Alcad Limited

Sweden

Telephone: +46 491 68 100

Facsimile: +46 491 68 110

www.alcad.com

Delivering quality

ALCAD



Single Cell Range

Technical manual

Delivering quality

ALCAD

ALCAD Single Cell Range

Contents

1. Introduction	3	7. Battery sizing principles in stationary standby applications	15
2. Benefits of the Alcad pocket plate Ni-Cd battery	4	7.1 The voltage window	15
2.1 Complete reliability	4	7.2 Discharge profile	15
2.2 Long cycle life	4	7.3 Temperature	15
2.3 Exceptionally long lifetime	4	7.4 State of charge or recharge time	15
2.4 Low maintenance	4	7.5 Ageing	16
2.5 Wide operating temperature range	4	7.6 Floating effect	16
2.6 Fast recharge	4	8. Battery charging	17
2.7 Resistance to mechanical abuse	4	8.1 Charging generalities	17
2.8 High resistance to electrical abuse	4	8.2 Constant voltage charging methods	17
2.9 Simple installation	4	8.3 Charge acceptance	18
2.10 Extended storage	4	8.4 Charge efficiency	20
2.11 Well-proven pocket plate construction	4	8.5 Temperature effects	20
2.12 Environmentally safe	4	8.6 Commissioning	20
2.13 Low life-cycle cost	4	9. Special operating factors	21
3. Electrochemistry of Ni-Cd batteries	5	9.1 Electrical abuse	21
4. Construction features of the pocket plate battery	6	9.2 Mechanical abuse	21
4.1 Plate assembly	7	10. Installation and operating instructions	22
4.2 Separation	8	10.1 Receiving the shipment	22
4.3 Electrolyte	8	10.2 Storage	22
4.4 Terminal pillars	8	10.3 Installation	22
4.5 Venting system	8	10.4 Commissioning	24
4.6 Cell container	8	10.5 Charging in service	24
5. Battery types and applications	9	10.6 Periodic maintenance	25
5.1 Type L	9	10.7 Changing electrolyte	25
5.2 Type M	9	11. Maintenance of batteries in service	26
5.3 Type H	9	11.1 Cleanliness/mechanical	26
5.4 Choice of type	9	11.2 Topping-up	26
5.5 Applications	9	11.3 Capacity check	27
6. Operating features	10	11.4 Recommended maintenance procedure	27
6.1 Capacity	10	12. Disposal and recycling	28
6.2 Cell voltage	10		
6.3 Internal resistance	10		
6.4 Effect of temperature on performance	11		
6.5 Short-circuit values	12		
6.6 Open circuit loss	12		
6.7 Cycling	12		
6.8 Effect of temperature on lifetime	13		
6.9 Water consumption and gas evolution	14		

1 Introduction

The nickel-cadmium battery is the most reliable battery system available in the market today. Its unique features enable it to be used in applications and environments untenable for other widely available battery systems.

It is not surprising, therefore, that the nickel-cadmium battery has become an obvious first choice for users looking for a reliable, long life, low maintenance system.

This manual details the design and operating characteristics of the Alcad pocket plate battery to enable a successful battery system to be achieved. A battery which, while retaining all the advantages arising from nearly 100 years of development of the pocket plate technology, can be so worry free that its only major maintenance requirement is topping-up with water.



2 Benefits of the Alcad pocket plate Ni-Cd battery

2.1 Complete reliability

The Alcad battery does not suffer from the sudden death failure associated with the lead acid battery (see section 4.1 Plate assembly).

2.2 Long cycle life

The Alcad battery has a long cycle life even when the charge/discharge cycle involves 100% depth of discharge (see section 6.7 Cycling).

2.3 Exceptionally long lifetime

A lifetime in excess of twenty years is achieved by the Alcad battery in many applications, and at elevated temperatures it has a lifetime unthinkable for other widely available battery technologies (see section 6.8 Effect of temperature on lifetime).

2.4 Low maintenance

With its generous electrolyte reserve, the Alcad battery reduces the need for topping-up with water, and can be left in remote sites for long periods without any maintenance (see section 6.9 Water consumption and gas evolution).

2.5 Wide operating temperature range

The Alcad battery has an electrolyte which allows it to have a normal operating temperature of from -20°C to $+50^{\circ}\text{C}$ (-4°F to $+122^{\circ}\text{F}$), and to accept extreme temperatures, ranging from as low as -50°C to up to $+70^{\circ}\text{C}$ (-58°F to up to $+158^{\circ}\text{F}$) (see section 4.3 Electrolyte).

2.6 Fast recharge

The Alcad battery can be recharged at currents which allow very fast recharge times to be achieved (see section 8.3 Charge acceptance).

2.7 Resistance to mechanical abuse

The Alcad battery is designed to have the mechanical strength required to withstand all the harsh treatment associated with transportation over difficult terrain (see section 9.2 Mechanical abuse).

2.8 High resistance to electrical abuse

The Alcad battery will survive abuse which would destroy a lead acid battery, for example overcharging, deep discharging, and high ripple currents (see section 9.1 Electrical abuse).

2.9 Simple installation

The Alcad battery can be used with a wide range of stationary and mobile applications as it produces no corrosive vapours, uses corrosion-free polypropylene containers and has a simple bolted connector assembly system (see section 10 Installation and operating instructions).

2.10 Extended storage

When stored in the empty and discharged state under the recommended conditions, the Alcad battery can be stored for many years (see section 10.2 Storage).

2.11 Well-proven pocket plate construction

Alcad has nearly 100 years of manufacturing and application experience with respect to the nickel-cadmium pocket plate product, and this expertise has been built into the twenty-plus years' design life of the battery (see section 4 Construction features of the pocket plate battery).

2.12 Environmentally safe

Alcad operates a dedicated recycling centre to recover the nickel, cadmium, steel and plastic used (see section 12 Disposal and recycling).

2.13 Low life-cycle cost

When all the factors of lifetime, low maintenance requirements, simple installation and storage and resistance to abuse are taken into account, the Alcad battery becomes the most cost effective solution for many professional applications.

3 Electrochemistry of Ni-Cd batteries

The nickel-cadmium battery uses nickel hydroxide as the active material for the positive plate, and cadmium hydroxide for the negative plate.

The electrolyte is an aqueous solution of potassium hydroxide containing small quantities of lithium hydroxide to improve cycle life and high temperature operation.

The electrolyte is only used for ion transfer; it is not chemically changed or degraded during the charge/discharge cycle. In the case of the lead acid battery, the positive and negative active materials chemically react with the sulphuric acid electrolyte resulting in an ageing process.

The support structure of both negative and positive plates is steel. This is unaffected by the electrolyte, and retains its strength throughout the life of the cell. In the case of the lead acid battery, the basic structure of both plates are lead and lead oxide which play a part in the electrochemistry of the process and are naturally corroded during the life of the battery.

The charge/discharge reaction of a nickel-cadmium battery is as follows:

During discharge the trivalent nickel hydroxide is reduced to divalent nickel hydroxide, and the cadmium at the negative plate forms cadmium hydroxide.

On charge, the reverse reaction takes place until the cell potential rises to a level where hydrogen is evolved at the negative plate and oxygen at the positive plate which results in water loss.

Unlike the lead acid battery, there is little change in the electrolyte density during charge and discharge. This allows large reserves of electrolyte to be used without inconvenience to the electrochemistry of the couple.

Thus, through its electrochemistry, the nickel-cadmium battery has a more stable behaviour than the lead acid battery, giving it a longer life, superior characteristics and a greater resistance against abusive conditions.

Nickel-cadmium cells have a nominal voltage of 1.2 volts (V).

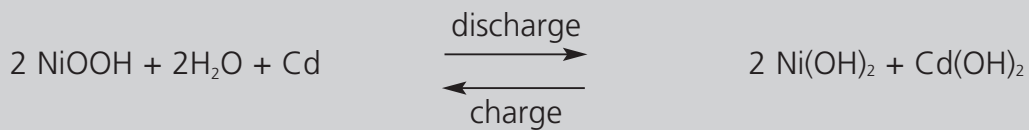

4 Construction features of the pocket plate battery

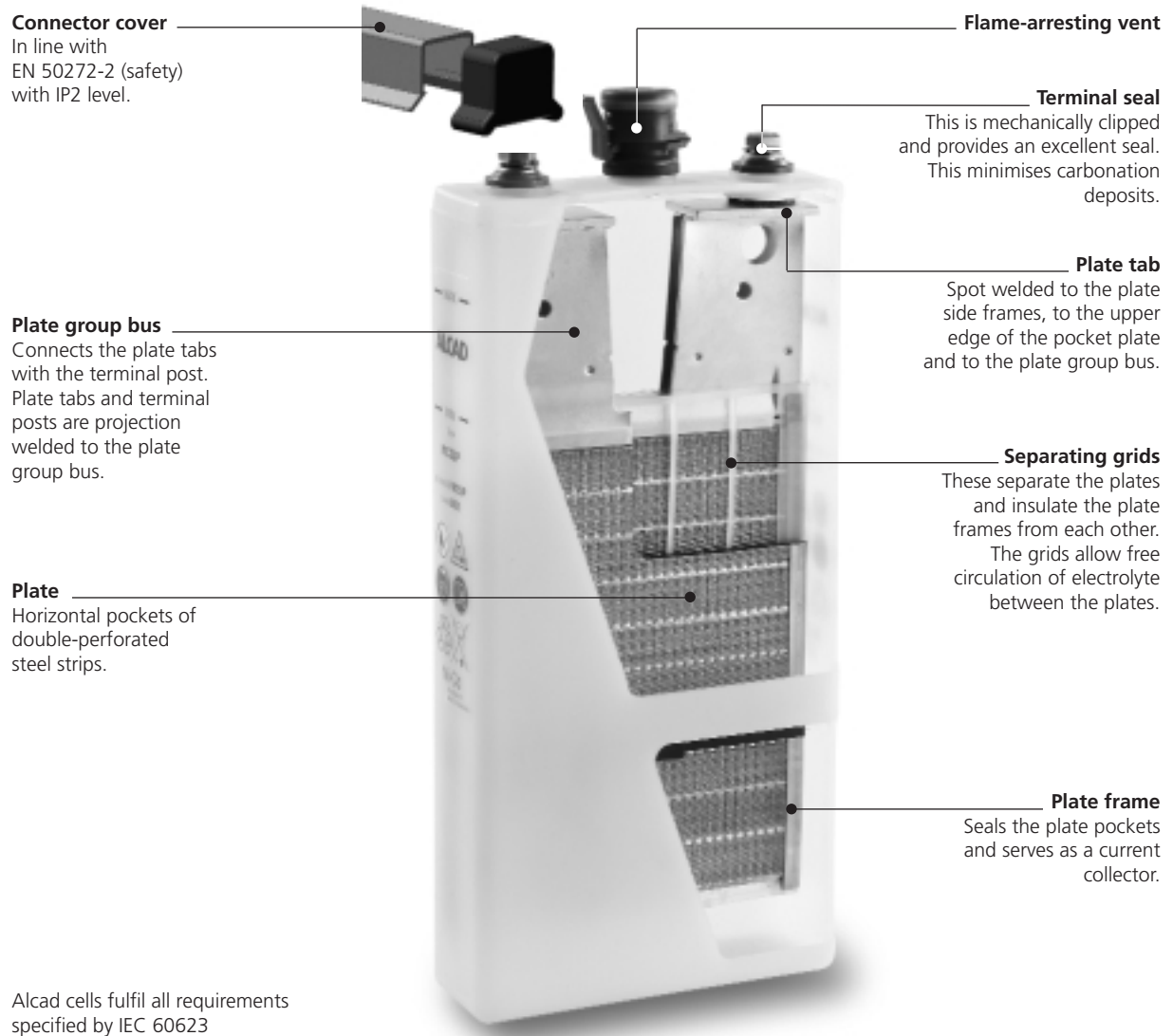

4.1 Plate assembly

The nickel-cadmium cell consists of two groups of plates, the positive containing nickel hydroxide and the negative containing cadmium hydroxide.

The active materials of the Alcad pocket plate battery are retained in pockets formed from steel strips double-perforated by a patented process.

These pockets are mechanically linked together, cut to the size corresponding to the plate width and compressed to the final plate dimension. This process leads to a plate which is not only mechanically very strong but also retains its active material within a steel containment which promotes conductivity and minimises electrode swelling.

These plates are then welded to a current carrying bus bar assembly which further ensures the mechanical and electrical stability of the product.

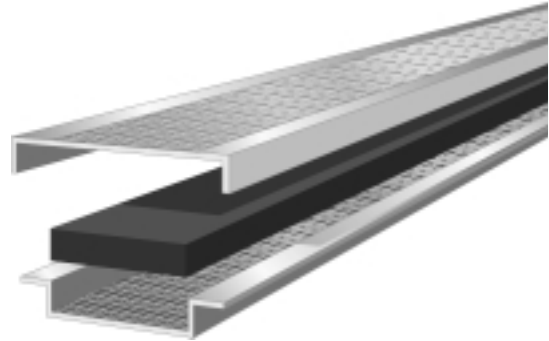

Nickel-cadmium batteries have an exceptionally good lifetime and cycle life because their plates are not gradually weakened by corrosion, as the structural component of the plate is steel. The active material of the plate is not structural, only electrical. The alkaline electrolyte does not react with steel, which means that the supporting structure of the battery stays intact and unchanged for the life of the battery. There is no corrosion and no risk of "sudden death".

In contrast, the lead plate of a lead acid battery is both the structure and the active material and this leads to shedding of the positive plate material and eventual structural collapse.

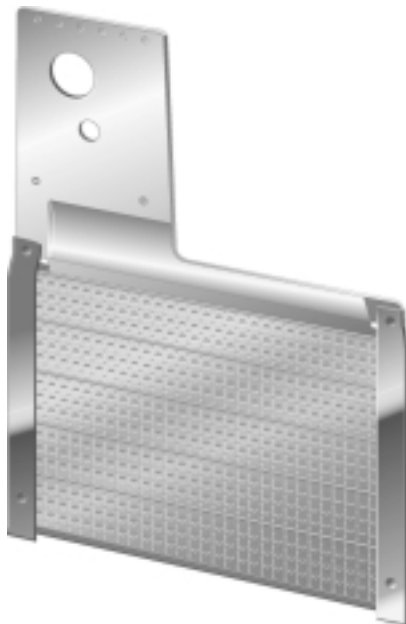

4.2 Separation

Separation between plates is provided by injection molded plastic separator grids, integrating both plate edge insulation and plate separation.

By providing a large spacing between the positive and negative plates and a generous quantity of electrolyte between plates, good electrolyte circulation and gas dissipation are provided, and there is no stratification of the electrolyte as found with lead acid batteries.

4.3 Electrolyte

The electrolyte used in the Alcad battery, a solution of potassium hydroxide and lithium hydroxide, is optimised to give the best combination of performance, life, energy efficiency and a wide temperature range.

The concentration of the standard electrolyte is such as to allow the cell to be operated to temperature extremes as low as -20°C (-4°F) and as high as $+50^{\circ}\text{C}$ ($+122^{\circ}\text{F}$). This allows the very high temperature fluctuation found in certain regions to be accommodated.

For very low temperatures a special high density electrolyte can be used.

The electrode material is less reactive with the alkaline electrolyte (nickel-cadmium secondary batteries) than with acid electrolytes (lead acid secondary batteries). Furthermore, during charging and discharging in alkaline batteries the electrolyte works mainly as a carrier of oxygen or hydroxyl ions from one electrode to the other; hence the composition or the concentration of the electrolyte does not change noticeably. In the charge/discharge reaction of the nickel-cadmium battery, the potassium hydroxide is not mentioned in the reaction formula. A small amount of water is produced during the charging procedure (and consumed during the discharge). The amount is not enough to make it possible to detect if the battery is charged or discharged by measuring the density of the electrolyte.

Once the battery has been filled with the correct electrolyte either at the battery factory or during the battery commissioning there is no need to check the electrolyte density periodically. The density of the electrolyte in the battery either increases or decreases as the electrolyte level drops because of water electrolysis or evaporation or rises at topping-up. Interpretation of density measurements is difficult and could be misleading.

In most applications the electrolyte will retain its effectiveness for the life of the battery and will never need replacing. However, under certain conditions, such as extended use in high temperature situations, the electrolyte can become carbonated.

If this occurs the battery performance can be improved by replacing the electrolyte.

The standard electrolyte used for the first fill in cells is E22 and for replacement in service is E13.

4.4 Terminal pillars

Short terminal pillars are welded to the plate bus bars using a well established and proven method. These posts are manufactured from steel bar, internally threaded for bolting on connectors, and nickel-plated.

The sealing between the cover and the terminal is provided by a compressed visco-elastic sealing surface held in place by compression lock washers. This assembly is designed to provide satisfactory sealing throughout the life of the product.

4.5 Venting system

The Alcad battery is fitted with a special flame-arresting flip-top vent to give an effective and safe venting system.

4.6 Cell container

The material in the cell containers is translucent polypropylene, a tough and well-proven plastic for battery use. The lid and container are welded together by heat sealing, creating a homogeneous joint.

5 Battery types and applications

In order to provide an optimum solution for the wide range of battery applications which exist, the Alcad battery is constructed in three performance ranges.

5.1 Type L

The L type is designed for applications where the battery is required to provide a reliable source of energy over relatively long discharge periods.

Normally, the current is relatively low in comparison with the total stored energy, and the discharges are generally infrequent. Typical uses are power back-up and bulk energy storage.

5.2 Type M

The M type is designed for applications where the batteries are usually required to sustain electrical loads for between 30 minutes to 3 hours or for "mixed" loads which involve a mixture of high and low discharge rates. The applications can have frequent or infrequent discharges. The range is typically used in power back-up applications.

5.3 Type H

The H type is designed for applications where there is a demand for a relatively high current over short periods, usually less than 30 minutes in duration. The applications can have frequent or infrequent discharges.

The range is typically used in starting and power back-up applications.

5.4 Choice of type

In performance terms the ranges cover the full time spectrum from rapid high current discharges of a second to very long low current discharges of many hours. Table 1 shows in general terms the split between the ranges for the different discharge types. The choice is related to the discharge time and the end of discharge voltage. There are, of course, many applications where there are multiple discharges, and so the optimum range type should be calculated. This is explained in section 7 Battery sizing.

5.5 Applications

Alcad batteries are providing standby back-up and emergency power for industry and commerce, government and defence departments, electricity supply and distribution installations, railway authorities, hospitals, airports, public buildings, bus and commercial vehicle companies, communications networks, oil and petrochemical industries, etc. The applications are all industrial applications such as emergency lighting, switchgear, UPS, process control, data and information systems, security and fire alarm systems, signalling, turbine and engine starting and electric train duties.

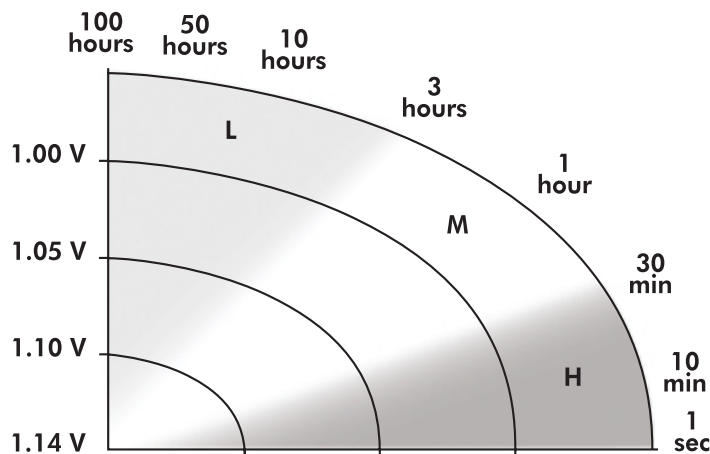

Table 1– General selection of cell range

6 Operating features

6.1 Capacity

The nickel-cadmium battery capacity is rated in ampere-hours (Ah) and is the quantity of electricity at +20°C (+68°F) which it can supply for a 5 hour discharge to 1.0 V after being fully charged for 7.5 hours at 0.2 C₅ A. This figure conforms to the IEC 60623 standard.

According to the IEC 60623 (Edition 4), 0.2 C₅ A is also expressed as 0.2 I_t A. The reference test current (I_t) is expressed as:

$$I_t A = \frac{C_n \text{ Ah}}{1 \text{ h}}$$

where:

C_n is the rated capacity declared by the manufacturer in ampere-hours (Ah),
and

n is the time base in hours (h) for which the rated capacity is declared.

6.2 Cell voltage

The cell voltage of nickel-cadmium cells results from the electrochemical potentials of the nickel and the cadmium active materials in the presence of the potassium hydroxide electrolyte. The nominal voltage for this electrochemical couple is 1.2 V.

6.3 Internal resistance

The internal resistance of a cell varies with the temperature and the state of charge and is, therefore, difficult to define and measure accurately.

The most practical value for normal applications is the discharge voltage response to a change in discharge current.

The internal resistance of an Alcad pocket plate cell depends on the performance type and size. The normal values are given in the performance data brochures.

The normal values are for fully charged cells. For lower states of charge the values increase. For cells 50% discharged the internal resistance is about 20% higher, and when 90% discharged, it is about 80% higher. The internal resistance of a fully discharged cell has very little meaning.

Reducing the temperature also increases the internal resistance, and at 0°C (+32°F), the internal resistance is about 40% higher.

6.4 Effect of temperature on performance

Variations in ambient temperature affect the performance of the cell and this needs to be taken into account when sizing the battery.

Low temperature operation has the effect of reducing the performance, but the higher temperature

characteristics are similar to those at normal temperatures. The effect of low temperature is more marked at higher rates of discharge.

The factors which are required in sizing a battery to compensate for temperature variations are given in a graphical form in Figure 1(a), H type, Figure 1(b), M type and Figure 1(c) L type for operating temperatures from -20°C to $+50^{\circ}\text{C}$ (-4°F to $+122^{\circ}\text{F}$).

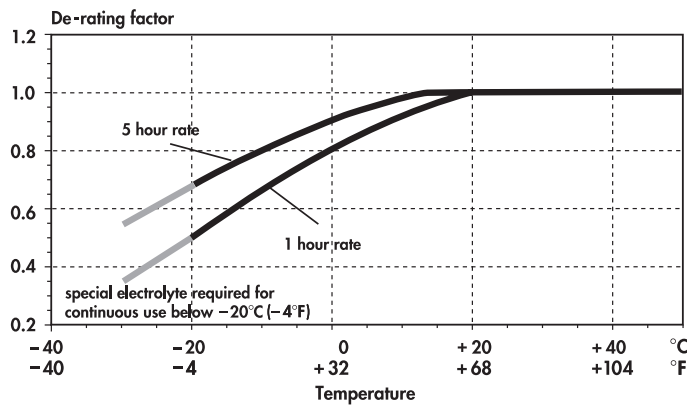

Figure 1 (a) – Temperature de-rating factors for L type cell

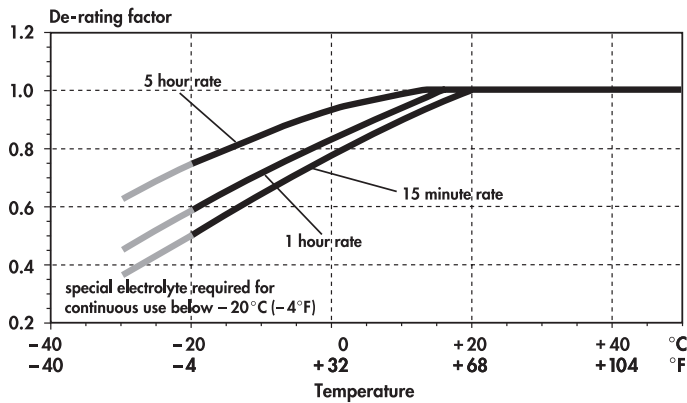

Figure 1 (b) – Temperature de-rating factors for M type cell

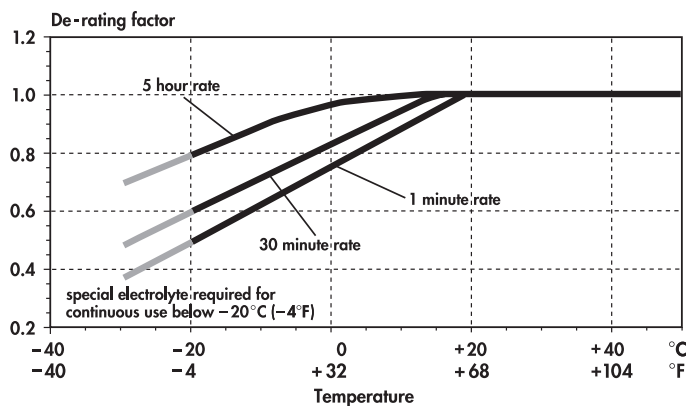

Figure 1 (c) – Temperature de-rating factors for H type cell

6.5 Short-circuit values

The typical short-circuit value in amperes for an Alcad pocket plate battery cell is approximately 9 times the ampere-hour capacity for L type, 16 times the ampere-hour capacity for M type and 28 times the ampere-hour capacity for H type.

A battery with conventional bolted assembly connections will withstand a short-circuit current of this magnitude for many minutes without damage.

6.6 Open circuit loss

The state of charge of a cell on open circuit slowly decreases with time due to self-discharge. In practice this decrease is relatively rapid during the first two weeks, but then stabilises to about 2% per month at +20°C (+68°F).

The self-discharge characteristics of a nickel-cadmium cell are affected by the temperature. At low temperatures, the charge retention is better than at normal temperature, and so the open circuit loss is reduced. However, the self-discharge is significantly increased at higher temperatures.

The typical open circuit loss for a pocket plate battery for a range of temperatures which may be experienced in a stationary application is shown in Figure 2.

6.7 Cycling

The Alcad battery is designed to withstand the wide range of cycling behaviour encountered in stationary applications. This can vary from low depth of discharges to discharges of up to 100% and the number of cycles that the product will be able to provide will depend on the depth of discharge.

The less deeply a battery is cycled, the greater the number of cycles it is capable of performing before it is unable to achieve the minimum design limit. A shallow cycle will give many thousands of operations, whereas a deep cycle will give only hundreds of operations.

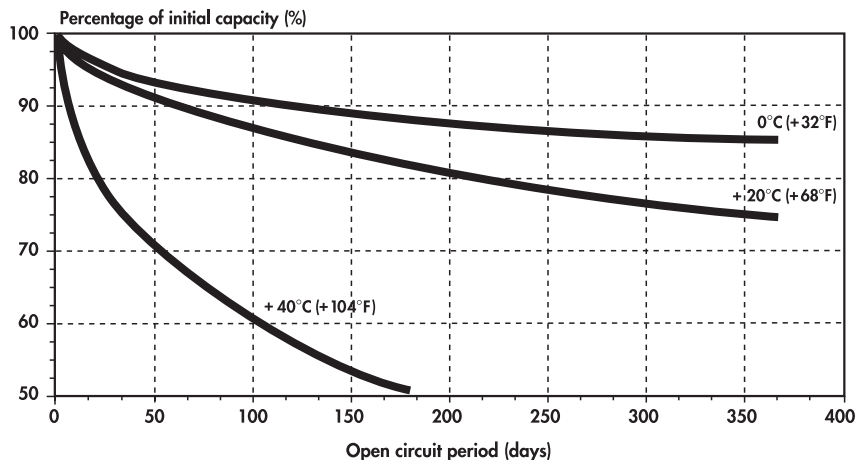

Figure 2 – Capacity loss on open circuit stand

Figure 3 gives typical values for the effect of depth of discharge on the available cycle life, and it is clear that when sizing the battery for a cycling application, the number and depth of cycles have an important consequence on the predicted life of the system.

6.8 Effect of temperature on lifetime

The Alcad battery is designed as a twenty year life product, but as with every battery system, increasing temperature reduces the expected life. However, the reduction in lifetime with increasing temperature is very much lower for the nickel-cadmium battery than for the lead acid battery.

The reduction in lifetime for the nickel-cadmium battery, and for comparison, a high quality lead acid battery is shown graphically in Figure 4. The values

for the lead acid battery are as supplied by the industry and found in Eurobat and IEEE documentation.

In general terms, for every 9°C (16.2°F) increase in temperature over the normal operating temperature of +25°C (+77°F), the reduction in service life for a nickel-cadmium battery will be 20%, and for a lead acid battery will be 50%. In high temperature situations, therefore, special consideration must be given to dimensioning the nickel-cadmium battery. Under the same conditions, the lead acid battery is not a practical proposition, due to its very short lifetime. The valve-regulated lead acid (VRLA) battery, for example, which has a lifetime of about 7 years under good conditions, has this reduced to less than 1 year, if used at +50°C (+122°F).

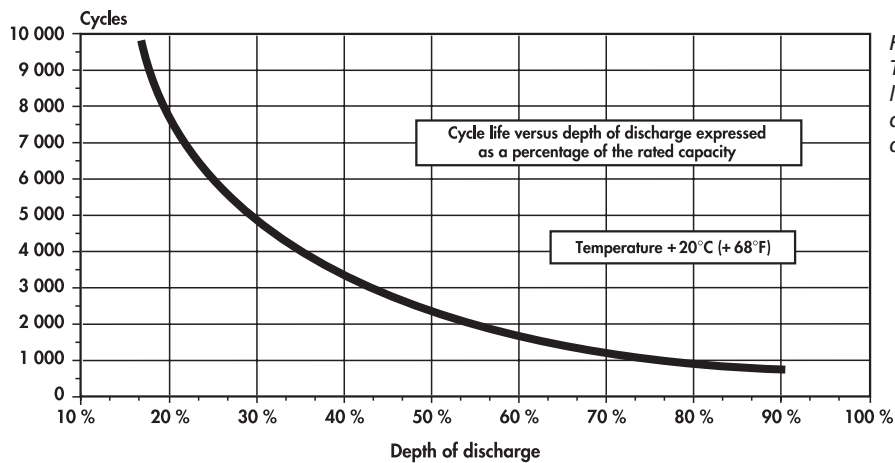

Figure 3 – Typical cycle life versus depth of discharge

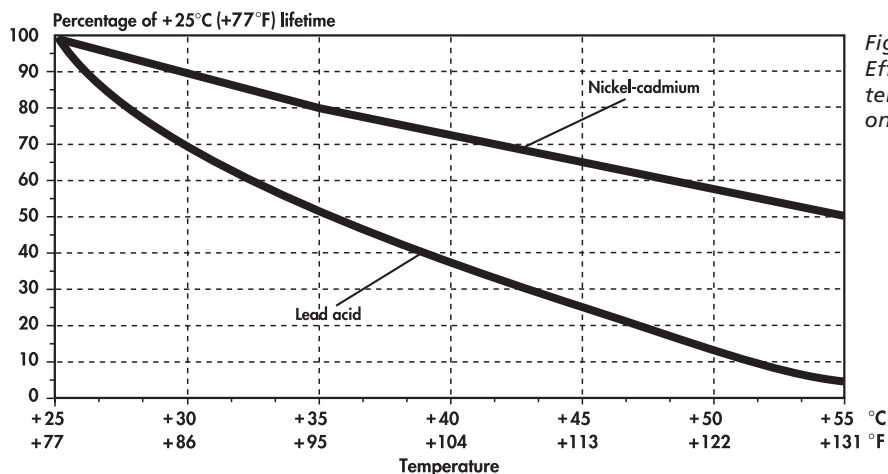

Figure 4 – Effect of temperature on lifetime

6.9 Water consumption and gas evolution

During charging, more ampere-hours are supplied to the battery than the capacity available for discharge. These additional ampere-hours must be provided to return the battery to the fully charged state and, since they are not all retained by the cell and do not all contribute directly to the chemical changes to the active materials in the plates, they must be dissipated in some way. This surplus charge, or overcharge, breaks down the water content of the electrolyte into oxygen and hydrogen, and pure distilled or deionized water has to be added to replace this loss.

Water loss is associated with the current used for overcharging. A battery which is constantly cycled, i.e. is charged and discharged on a regular basis, will consume more water than a battery on standby operation.

In theory, the quantity of water used can be found by the Faradic equation that each ampere-hour of overcharge breaks down 0.366 cm³ of water. However, in practice, the water usage will be less than this, as the overcharge current is also needed to counteract self-discharge of the electrodes.

The overcharge current is a function of both voltage and temperature, so both have an influence on the consumption of water. Figure 5 gives typical water consumption values over a range of voltages for different cell types.

Example : An MB 415 P is floating at 1.43 V/cell. The electrolyte reserve for this cell is 1400 cm³. From Figure 5, an M type cell at 1.43 V/cell will use 0.27 cm³/month for one Ah of capacity. Thus an MB 415 P will use 0.27 x 415 = 112 cm³ per month and the electrolyte reserve will be used in

$$\frac{1400}{112} = 12.5 \text{ months.}$$

The gas evolution is a function of the amount of water electrolysed into hydrogen and oxygen and are predominantly given off at the end of the charging period. The battery gives off no gas during a normal discharge.

The electrolysis of 1 cm³ of water produces 1865 cm³ of gas mixture and this gas mixture is in the proportion of 2/3 hydrogen and 1/3 oxygen. Thus the electrolysis of 1 cm³ of water produces 1243 cm³ of hydrogen.

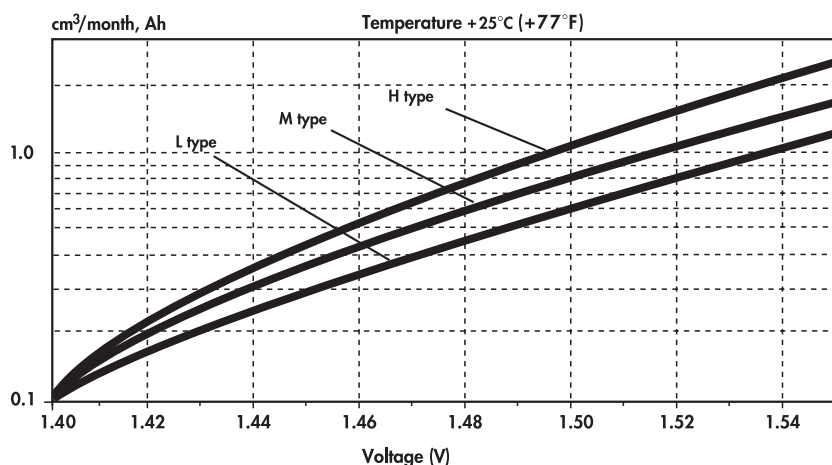

Figure 5 – Water consumption values for different voltages and cell types

7 Battery sizing principles in stationary standby applications

There are a number of methods which are used to size nickel-cadmium batteries for standby floating applications. The method employed by Alcad is the IEEE 1115 recommendation which is accepted internationally. The method takes into account multiple discharges, temperature de-rating, performance after floating and the voltage window available for the battery.

A significant advantage of the nickel-cadmium battery compared to a lead acid battery, is that it can be fully discharged without any inconvenience in terms of life or recharge. Thus, to obtain the smallest and least costly battery, it is an advantage to discharge the battery to the lowest practical value in order to obtain the maximum energy from the battery.

The principle sizing parameters which are of interest are:

7.1 The voltage window

This is the maximum voltage and the minimum voltage at the battery terminals acceptable for the system. In battery terms, the maximum voltage gives the voltage which is available to charge the battery, and the minimum voltage gives the lowest voltage acceptable to the system to which the battery can be discharged. In discharging the nickel-cadmium battery, the cell voltage should be taken as low as possible in order to find the most economic and efficient battery.

7.2 Discharge profile

This is the electrical performance required from the battery for the application. It may be expressed in terms of amperes for a certain duration, or it may be expressed in terms of power, in watts or kW, for a certain duration. The requirement may be simply one discharge or many discharges of a complex nature.

7.3 Temperature

The maximum and minimum temperatures and the normal ambient temperature will have an influence on the sizing of the battery. The performance of a battery decreases with decreasing temperature and sizing at a low temperature increases the battery size. Temperature de-rating curves are produced for all cell types to allow the performance to be recalculated.

7.4 State of charge or recharge time

Some applications may require that the battery shall give a full duty cycle after a certain time after the previous discharge. The factors used for this will depend on the depth of discharge, the rate of discharge, and the charge voltage and current. A requirement for a high state of charge does not justify a high charge voltage if the result is a high end of discharge voltage.

7.5 Ageing

Some customers require a value to be added to allow for the ageing of the battery over its lifetime. This may be a value required by the customer, for example 10%, or it may be a requirement from the customer that a value is used which will ensure the service of the battery during its lifetime. The value to be used will depend on the discharge rate of the battery and the conditions under which the discharge is carried out.

7.6 Floating effect

When a nickel-cadmium cell is maintained at a fixed floating voltage over a period of time, there is a decrease in the voltage level of the discharge curve. This effect begins after one week and reaches its maximum in about 3 months. It can only be eliminated by a full discharge/charge cycle and cannot be eliminated by a boost charge.

It is therefore necessary to take this into account in any calculations concerning batteries in float applications.

As the effect of reducing the voltage level is to reduce the autonomy of the battery, the effect can be considered as reducing the performance of the battery and so performance down-rating factors are used.

8 Battery charging

8.1 Charging generalities

The Alcad battery can be charged by all normal methods. Generally, batteries in parallel operation with charger and load are charged with constant voltage. In operations where the battery is charged separately from the load, charging with constant current or declining current is possible. High-rate charging or overcharging will not damage the battery, but excessive charging will increase water consumption to some degree.

8.2 Constant voltage charging methods

Batteries in stationary applications are normally charged by a constant voltage float system and this can be of two types: the two-rate type, where there is an initial constant voltage charge followed by a lower floating voltage; or a single rate floating voltage.

The single voltage charger is necessarily a compromise between a voltage high enough to give an acceptable charge time and low enough to give a low water usage. However, it does give a simpler charging system and accepts a smaller voltage window than the two-rate charger.

The two-rate charger has an initial high voltage stage to charge the battery followed by a lower voltage maintenance charge. This allows the battery to be charged quickly, and yet, have a low water consumption due to the low maintenance charge or float voltage level.

The values used for the Alcad pocket plate battery ranges for single and two-rate charge systems are as shown in Table 2 below.

To minimise the water usage, it is important to use a low charge voltage per cell, and so the minimum voltage for the single level and the two level charge voltage is the normally recommended value. This also helps within a voltage window to obtain the lowest, and most effective, end of discharge voltage per cell (see section 7 Battery sizing).

The values given as maximum are acceptable to the battery, but would not normally be used in practice, particularly for the single level, because of high water usage.

Cell type	Single level: (V/cell)		Two level: (V/cell)		
	min	max	min	max	floating
L	1.43	1.50	1.47	1.70	1.42 ± 0.01
M	1.43	1.50	1.45	1.70	1.40 ± 0.01
H	1.43	1.50	1.45	1.70	1.40 ± 0.01

Table 2 – Charge and float voltages for the Alcad pocket plate battery ranges

8.3 Charge acceptance

A discharged cell will take a certain time to achieve a full state of charge. Figures 6(a), (b) and (c) give the capacity available for typical charging voltages recommended for the pocket plate battery range during the first 30 hours of charge from a fully discharged state.

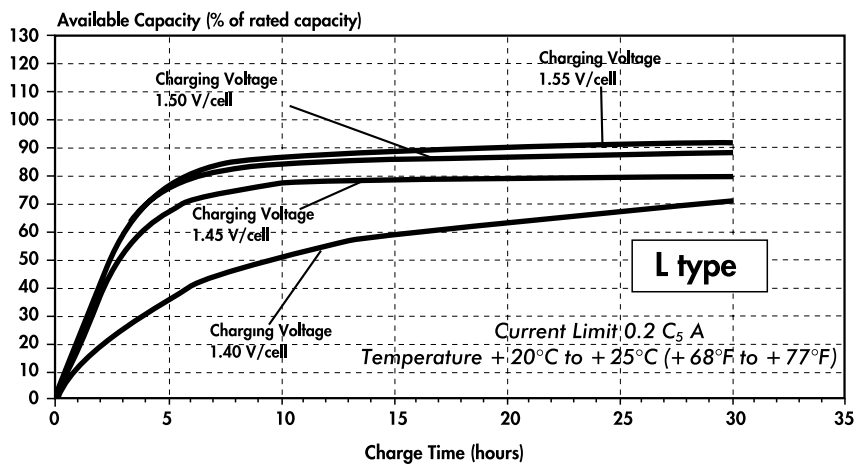

Figure 6(a) – Typical recharge times from a fully discharged state for the L type cell

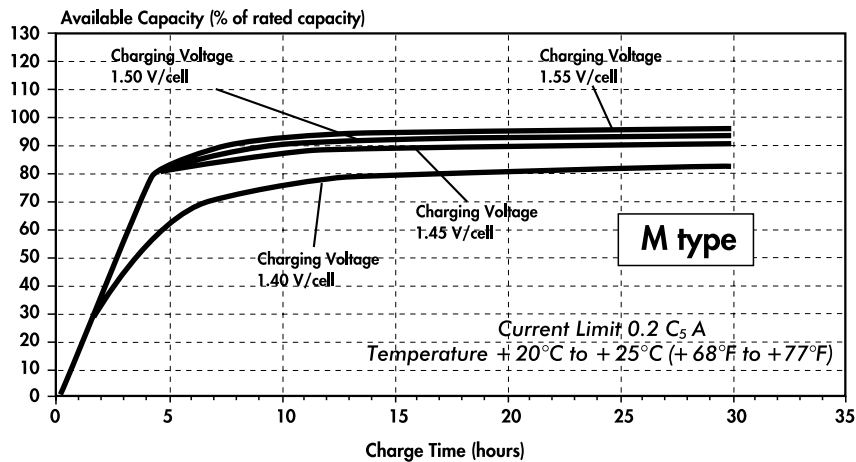

Figure 6(b) – Typical recharge times from a fully discharged state for the M type cell

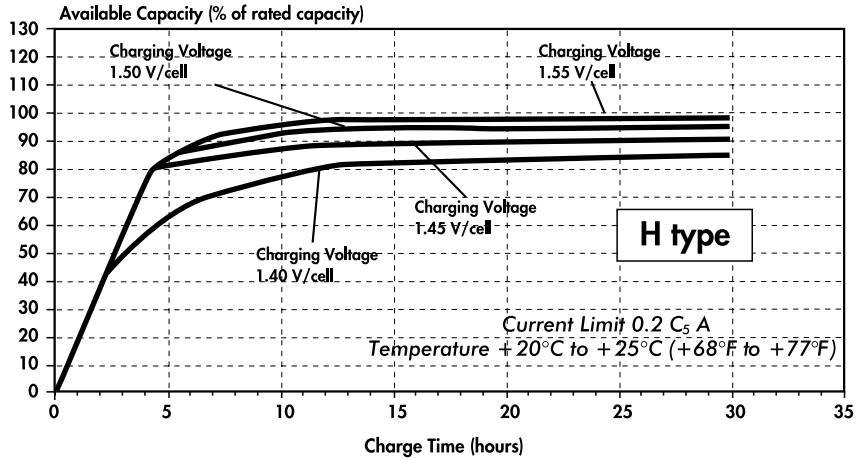

Figure 6(c) – Typical recharge times from a fully discharged state for the H type cell

These graphs give the recharge time for a current limit of $0.2 C_5$ amperes. Clearly, if a lower value for the current is used, e.g. $0.1 C_5$ amperes, then the battery will take longer to charge.

If a higher current is used then it will charge more rapidly. This is not in general a pro rata relationship due to the limited charging voltage.

The charge time for an M type cell at different charge regimes for a fixed voltage is given in Figure 6(d).

If the application has a particular recharge time requirement then this must be taken into account when calculating the battery.

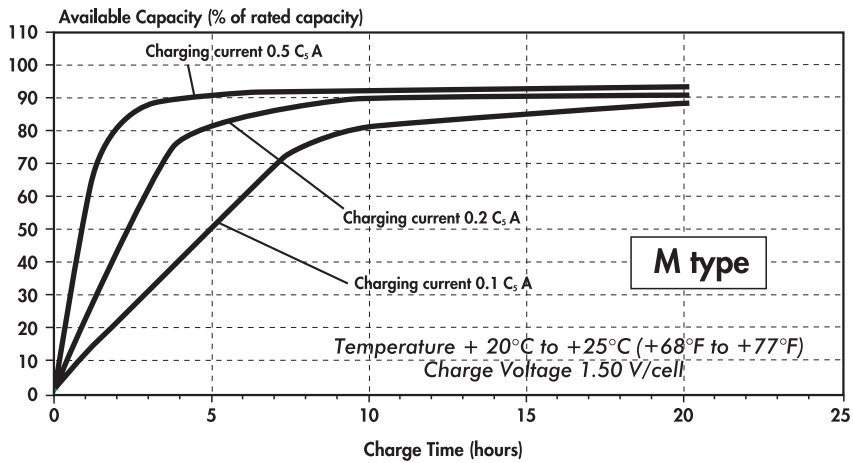

Figure 6(d) – Typical recharge times for different charge rates for the M type cell

8.4 Charge efficiency

The charge efficiency of the battery is dependent on the state of charge of the battery and the temperature. For much of its charge profile, it is recharged at a high level of efficiency.

In general, at states of charge less than 80% the charge efficiency remains high, but as the battery approaches a fully charged condition, the charging efficiency falls off.

8.5 Temperature effects

As the temperature increases, the electrochemical behaviour becomes more active, and so, for the same floating voltage, the current increases. As the temperature is reduced then the reverse occurs. Increasing the current increases the water loss, and reducing the current creates the risk that the cell will not be sufficiently charged.

For standby application, it is normally not required to compensate the charging voltage with the temperature. However if water consumption is of main concern, temperature compensation should be used if the battery is operating at high temperature such as +35°C (+95°F).

At low temperature (< 0°C/+32°F), there is a risk of poor charging and it is recommended either to adjust the charging voltage or to compensate the charging voltage with the temperature (value: -3 mV/°C / -1.7mV/°F), starting from an ambient temperature of +20°C to +25°C (+68°F to +77°F).

8.6 Commissioning*

It is recommended that a good first charge should be given to the battery. This is a once only operation, and is essential to prepare the battery for its long service life. It is also important for discharged and empty cells which have been filled, as they will be in a totally discharged state.

A constant current first charge is preferable and this should be such as to supply 200% of the rated capacity of the cell. Thus, a 250 Ah cell will require 500 ampere-hours input, e.g. 50 amperes for 10 hours.

*Please refer to the operating instructions in section 10.

9 Special operating factors

9.1 Electrical abuse

Ripple effects

The nickel-cadmium battery is tolerant to high ripple and will accept ripple currents of up to $0.2 C_5 A I_{\text{eff}}$. In fact, the only effect of a high ripple current is that of increased water usage. Thus, in general, any commercially available charger or generator can be used for commissioning or maintenance charging of the Alcad battery. This contrasts with the valve-regulated lead acid battery (VRLA) where relatively small ripple currents can cause battery overheating, and will reduce life and performance.

Over-discharge

If more than the designed capacity is taken out of a battery then it becomes deep discharged and reversed. This is considered to be an abuse situation for a battery and should be avoided.

In the case of lead acid batteries this will lead to failure of the battery and is unacceptable.

The Alcad battery will not be damaged by over-discharge but must be recharged to compensate for the over-discharge.

Overcharge

In the case of the Alcad battery, with its generous electrolyte reserve, a small degree of overcharge over a short period will not significantly alter the maintenance period. In the case of excessive overcharge, water replenishment is required, but there will be no significant effect on the life of the battery.

9.2 Mechanical abuse

Shock loads

The Alcad battery concept has been tested to IEC 68-2-29 (bump tests at 5 g, 10 g and 25 g) and IEC 77 (shock test 3 g), where g = acceleration.

Vibration resistance

The Alcad battery concept has been tested to IEC 77 for 2 hours at 1 g, where g = acceleration.

External corrosion

The Alcad battery is manufactured in durable polypropylene. All external metal components are nickel-plated or stainless steel, protected by an anti-corrosion oil, and then protected by a rigid plastic cover.

10 Installation and operating instructions

Important recommendations

- **Never allow an exposed flame or spark near the batteries, particularly while charging.**
- **Never smoke while performing any operation on the battery.**
- **For protection, wear rubber gloves, long sleeves, and appropriate splash goggles or face shield.**
- **The electrolyte is harmful to skin and eyes. In the event of contact with skin or eyes, wash immediately with plenty of water. If eyes are affected, flush with water, and obtain immediate medical attention.**
- **Remove all rings, watches and other items with metal parts before working on the battery.**
- **Use insulated tools.**
- **Avoid static electricity and take measures for protection against electric shocks.**
- **Discharge any possible static electricity from clothing and/or tools by touching an earth-connected part “ground” before working on the battery.**

10.1 Receiving the shipment

Unpack the battery immediately upon arrival. Do not overturn the package. Transport seals are located under the cover of the vent plug.

- **The battery is normally shipped discharged and empty.** Do not remove the plastic transport seals until ready to fill the battery.
- **If the battery is shipped filled and charged,** the battery is ready for installation. Remove the plastic transport seals only before use.

The battery must never be charged with the plastic transport seals in place as this can cause permanent damage.

10.2 Storage

Store the battery indoors in a dry, clean, cool location (0°C to +30°C/+32°F to +86°F) and well ventilated space on open shelves.

Do not store in direct sunlight or expose to excessive heat.

■ Cells empty and discharged

- Alcad recommends to store cells empty and discharged. This ensures compliance with IEC 60623 section 4.9 (storage).
- Cells can be stored like this for many years.

■ Cells filled and charged

- If cells are stored filled, they must be fully charged prior to storage.
- Cells may be stored filled and charged for a period not exceeding 12 months from date of dispatch.

Storage of a filled battery at temperatures above +30°C (+86°F) can result in loss of capacity. This can be as much as 5% per 10°C (18°F) above +30°C (+86°F) per year.

- When deliveries are made in cardboard boxes, store without opening the boxes.
- **When deliveries are made in plywood boxes, open the boxes before storage. The lid and the packing material on top of the cells must be removed.**

10.3 Installation

10.3.1 Location

Install the battery in a dry and clean room. Avoid direct sunlight and heat.

The battery will give the best performance and maximum service life when the ambient temperature is between +10°C to +30°C (+50°F to +86°F).

Alcad batteries can be fitted on to stands, floor-mounted or fitted into cabinets.

Local standards or codes normally define the mounting arrangements of batteries, and these must be followed if applicable. However, if this is not the case, the following comments should be used as a guide.

When mounting the battery, it is desirable to maintain an easy access to all cells, they should be situated in a readily available position. Distances between stands, and between stands and walls, should be sufficient to give good access to the battery.

The overall weight of the battery must be considered and the load bearing on the floor taken into account in the selection of the battery accommodation.

If the battery is enclosed in a cabinet or other such enclosed space, it is important to provide sufficient space to disperse the gases given off during charging, and also to minimise condensation.

It is recommended that at least 200 mm be allowed above cell tops, to ensure easy access during inspection and topping-up, and that enough space is allowed between cabinet walls and the battery to avoid any risk of short-circuits. Flip-top vents may be turned through 180° to achieve the most convenient position for topping-up.

10.3.2 Ventilation

Special regulations for ventilation may be valid in your area depending on the applications.

When the battery is housed in a cubicle or enclosed compartment, it is necessary to provide adequate ventilation.

During the last part of high-rate charging, the battery is emitting gases (oxygen and hydrogen mixture).

If it is required to establish that the ventilation of the battery room is adequate, then it is necessary to calculate the rate of evolution of hydrogen to ensure that the concentration of hydrogen gas in the room is kept within safe limits.

The theoretical limit for hydrogen concentration is 4%. However, some standards call for more severe levels than this, and levels as low as 1% are sometimes required.

To calculate the ventilation requirements of a battery room, the following method can be used:

1 Ah of overcharge breaks down 0.366 cm³ of water, and 1 cm³ of water produces 1.865 litres of gas in the proportion 2/3 hydrogen and 1/3 oxygen. Thus 1 Ah of overcharge produces 0.42 litres of hydrogen.

Therefore, the volume of hydrogen evolved from a battery per hour

= number of cells x charge current x 0.42 litres

or

= number of cells x charge current x 0.00042 m³.

The volume of hydrogen found by this calculation can be expressed as a percentage of the total volume of

the battery room, and from this, the number of air changes required to keep the concentration of hydrogen below a certain level can be calculated.

Example:

A battery of 96 cells, type HB 280 P on a three step, two tier stand, is placed in a room of dimensions 3m x 5m x 3m.

The charging system is capable of charging at 0.1 C₅ and so the charging current is 28 amperes.

The volume of hydrogen evolved per hour in this, the worst, case is: = 96 x 28 x 0.00042 m³ = 1.13 m³.

The total volume of the room is 3 x 5 x 3 = 45m³

Approximate volume of battery and stand does not exceed 2 m³, and so, the volume of free air in the room is 43 m³.

Therefore, the concentration of hydrogen gas after charging for 1 hour at full gassing potential at 0.1 C₅ will be: = $\frac{1.13}{43} = 2.7\%$

Thus, to maintain a maximum concentration of 2% (for example), the air in the room will need changing

$$\frac{2.7}{2} = 1.4 \text{ times per hour.}$$

In practice, a typical figure for natural room ventilation is about 2.5 air changes per hour, and so, in this case, it would not be necessary to introduce any forced ventilation.

In a floating situation, the current flowing is very much lower than when the cell is being charged, and the gas evolution is minimal; it may be calculated in the same way using typical floating currents.

10.3.3 Mounting

Verify that cells are correctly interconnected with the appropriate polarity. The battery connection to load should be with nickel-plated cable lugs.

Recommended torques for terminal bolts are:

- M 6 = 11 ± 1.1 N.m
- M 8 = 20 ± 2 N.m
- M 10 = 30 ± 3 N.m

The connectors and terminal should be corrosion-protected by coating with a thin layer of anti-corrosion oil.

Remove the transport seals and close the vent plug.

10.3.4 Electrolyte/cell oil

■ Cells delivered filled and charged:

Check the level of electrolyte. It should not be more than 20 mm below the upper level mark. If this is not the case, adjust the level with distilled or deionized water. Cells delivered filled have already the cell oil in place.

■ Cells delivered empty and discharged:

If the electrolyte is supplied dry, prepare it according to its separate instructions sheet. The electrolyte to be used is E22. Remove the transport seals just before filling.

Fill the cells about 20 mm above the lower level mark with electrolyte.

Wait 4 to 24 hours and adjust if necessary before commissioning.

It is recommended to add the cell oil after the commissioning charge, with the syringe, according to the quantity indicated in the Installation and Operating Instructions sheet.

10.4 Commissioning

Verify that the ventilation is adequate during this operation.

A good commissioning is important. Charge at constant current is preferable.

When the charger maximum voltage setting is too low to supply constant current charging, divide the battery into two parts to be charged individually. If the current limit is lower than indicated in the table of the Installation and Operating Instructions sheet, charge proportionally for a longer time.

■ For cells filled on location or for filled cells which have been stored more than 6 months:

- charge 10 h at 0.2 C₅ A (recommended)
- or charge for 30 h at 1.65 V/cell, current limited to 0.2 C₅ A
- discharge at 0.2 C₅ A to 1.0 V/cell
- charge according to section below.

■ For cells filled and charged by the factory and stored less than 6 months:

- charge 10 h at 0.2 C₅ A (recommended)
- or charge 24 h at 1.65 V/cell, current limited to 0.2 C₅ A
- or charge 48 h at 1.55 V/cell, current limited to 0.2 C₅ A.

■ Cell oil and electrolyte after commissioning:

Wait for 4 hours after commissioning. Cells delivered filled by the factory have already the cell oil in place.

For cells filled on location, add the cell oil with the syringe.

Check the electrolyte level and adjust it to the upper level mark by adding:

- distilled or deionized water for cells filled by the factory
- electrolyte for cells filled on location.

The battery is ready for use.

10.5 Charging in service

■ Continuous parallel operation, with occasional battery discharge.

Recommended charging voltage
(+20°C to +25°C/+68°F to +77°F):

■ for two level charge:

- float level
= 1.42 ± 0.01 V/cell for L cells
= 1.40 ± 0.01 V/cell for M and H cells
- high level
= 1.47 - 1.70 V/cell for L cells
= 1.45 - 1.70 V/cell for M and H cells

A high voltage will increase the speed and efficiency of the recharging.

■ for single level charge: 1.43 - 1.50 V/cell.

■ Buffer operation, where the load exceeds the charger rating.

Recommended charging voltage
(+20°C to +25°C/+68°F to +77°F): 1.50 - 1.60 V/cell.

10.6 Periodic maintenance

- Keep the battery clean using only water. Do not use a wire brush or solvents of any kind. Vent plugs can be rinsed in clean water if necessary.
- Check the electrolyte level. Never let the level fall below the lower mark. Use only distilled or deionized water to top-up. Experience will tell the time interval between topping-up.

Note:

Once the battery has been filled with the correct electrolyte either at the battery factory or during the battery commissioning, there is no need to check the electrolyte density periodically.

Interpretation of density measurements is difficult and could be misleading.

- Check every two years that all connectors are tight. The connectors and terminal bolts should be corrosion-protected by coating with a thin layer of anti-corrosion oil.
- Check the charging voltage. It is important that the recommended charging voltage remains unchanged. The charging voltage should be checked at least once yearly. High water consumption of the battery is usually caused by improper voltage setting of the charger.

10.7 Changing electrolyte

In most stationary battery applications, the electrolyte will retain its effectiveness for the life of the battery. However, under special battery operating conditions, if the electrolyte is found to be carbonated, the battery performance can be restored by replacing the electrolyte.

The electrolyte type to be used for replacement in these cells is: E13.

Refer to "Electrolyte Instructions".

11 Maintenance of batteries in service

In a correctly designed standby application, the Alcad battery requires the minimum of attention. However, it is good practice with any system to carry out an inspection of the system at least once per year, or at the recommended topping-up interval period to ensure that the charger, the battery and the auxiliary electronics are all functioning correctly.

When this inspection is carried out, it is recommended that certain procedures should be carried out to ensure that the battery is maintained in a good state.

11.1 Cleanliness/mechanical

Cells must be kept clean and dry at all times, as dust and damp cause current leakage. Terminals and connectors should be kept clean, and any spillage during maintenance should be wiped off with a clean cloth. The battery can be cleaned, using water. Do not use a wire brush or a solvent of any kind. Vent caps can be rinsed in clean water, if necessary.

Check that the flame-arresting vents are tightly fitted and that there are no deposits on the vent caps.

Terminals should be checked for tightness, and the terminals and connectors should be corrosion-protected by coating with a thin layer of neutral grease or anti-corrosion oil.

11.2 Topping-up

Check the electrolyte level. Never let the level fall below the lower MIN mark. Use only approved distilled or deionized water to top-up. Do not overfill the cells.

Excessive consumption of water indicates operation at too high a voltage or too high a temperature. Negligible consumption of water, with batteries on continuous low current or float charge, could indicate under-charging. A reasonable consumption of water is the best indication that a battery is being operated under the correct conditions. Any marked change in the rate of water consumption should be investigated immediately.

The topping-up interval can be calculated as described in section 6.9. However, it is recommended that, initially, electrolyte levels should be monitored monthly to determine the frequency of topping-up required for a particular installation.

Alcad has a full range of topping-up equipment available to aid this operation.

11.3 Capacity check

Electrical battery testing is not part of normal routine maintenance, as the battery is required to give the back-up function and cannot be easily taken out of service.

However, if a capacity test of the battery is needed, the following procedure should be followed:

- a) Discharge the battery at the rate of $0.1 C_5$ to $0.2 C_5$ amperes (10 to 20 amperes for a 100 Ah battery) to a final average voltage of 1.0 V/cell (i.e. 92 volts for a 92 cell battery).
- b) Charge 200% (i.e. 200 Ah for a 100 Ah battery at the rate given in a)
- c) Discharge at the same rate used in a), measuring and recording current, voltage and time every hour, and more frequently towards the end of the discharge. This should be continued until a final average voltage of 1.0 V/cell is reached. The overall state of the battery can then be seen, and if individual cell measurements are taken, the state of each cell can be observed.

11.4 Recommended maintenance procedure

In order to obtain the best from your battery, the following maintenance procedure is recommended.

It is also recommended that a maintenance record be kept which should include a record of the temperature of the battery room.

Yearly
<ul style="list-style-type: none">• check charge voltage settings
<ul style="list-style-type: none">• check cell voltages (30 mV deviation from average is acceptable)
<ul style="list-style-type: none">• check float current of the battery
<ul style="list-style-type: none">• check electrolyte level
<ul style="list-style-type: none">• high voltage charge if agreed for application
Every 2 years
<ul style="list-style-type: none">• clean cell lids and battery areas• check torque values, grease terminals and connectors
Every 5 years or as required
<ul style="list-style-type: none">• capacity check
As required
<ul style="list-style-type: none">• top-up with water according to defined period (depend on float voltage, cycles and temperature).

12 Disposal and recycling

In a world where autonomous sources of electric power are ever more in demand, Alcad batteries provide an environmentally responsible answer to these needs. Environmental management lies at the core of Alcad's business and we take care to control every stage of a battery's life-cycle in terms of potential impact. Environmental protection is our top priority, from design and production through end-of-life collection, disposal and recycling.

Our respect for the environment is complemented by an equal respect for our customers. We aim to generate confidence in our products, not only from a functional standpoint, but also in terms of the environmental safeguards that are built into their life-cycle. The simple and unique nature of the battery components make them readily recyclable and this process safeguards valuable natural resources for future generations.

In partnership with collection agencies worldwide, Alcad organises retrieval from pre-collection points and the recycling of spent Alcad batteries. Information about Alcad's collection network can be found on our web site:

www.alcad.com

Ni-Cd batteries must not be discarded as harmless waste and should be treated carefully in accordance with local and national regulations. Your Alcad representative can assist with further information on these regulations and with the overall recycling procedure.

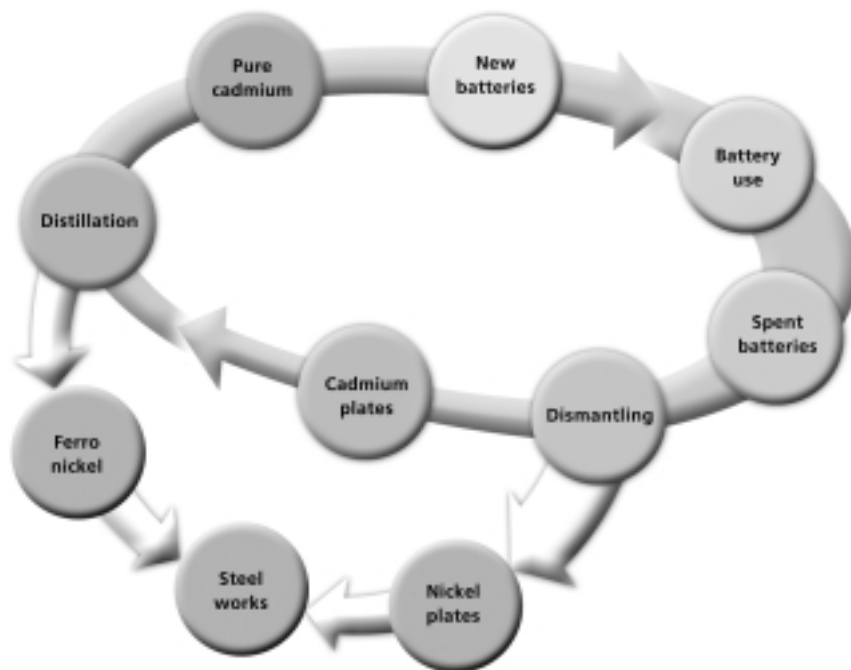

Complete topping-up equipment for Alcad Ni-Cd batteries

Alcad's complete topping-up equipment consists of a filling pistol "cell topper" and a water containment unit connected by a flexible hose. The filling pistol, which has a flow rate of 8 litres/min., shuts off at the correct level when the appropriate spacer tube is used.

Designed to simplify the water replenishment procedure for large sizes or numbers of cells, the equipment is effective especially where the electrolyte levels cannot be seen easily.

Safety precautions

- Remove all rings, watches, and other items with metal parts prior to working with battery.
- Wear protective gear, rubber gloves, long sleeves, closed goggles or shield.
- Never allow an exposed flame or spark near the battery.
- Never smoke while performing any operation on the battery.
- Discharge any possible static electricity from clothing and/or tools by touching an earth-connected part "ground" prior to working with the battery.
- Use insulated tools.
- Electrolyte is harmful to skin and eyes. In the event of contact with skin and eyes, wash immediately with plenty of water.

If eyes are affected, flush with water, and obtain immediate medical attention.

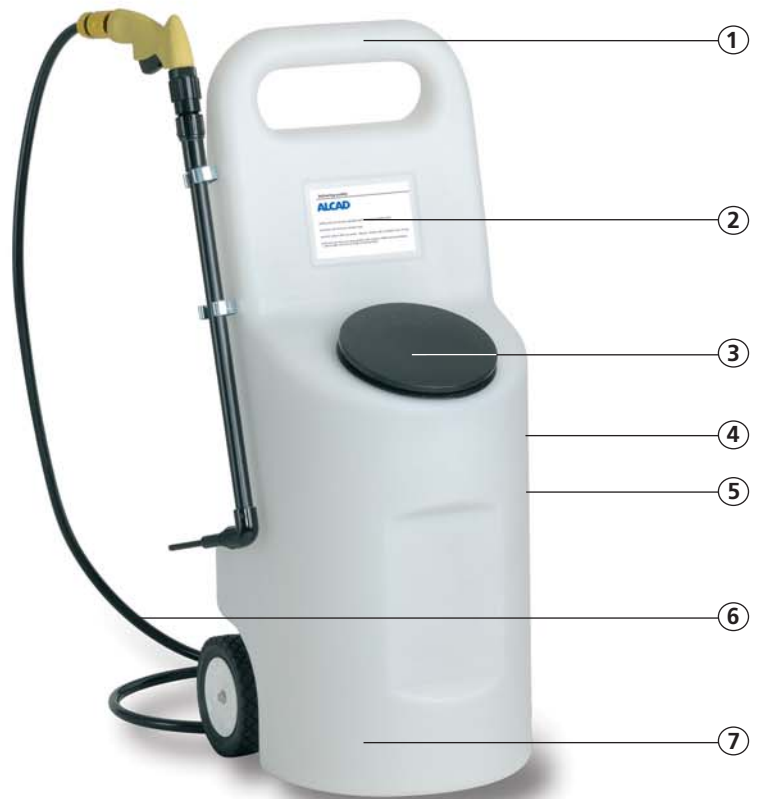

- ① Easy to manoeuvre: handles like a hand truck
- ② Easy to use: instructions displayed directly on the unit
- ③ Easy to fill: large opening
- ④ Dependable water source
- ⑤ On/off switch: located on the rear of the unit
- ⑥ Output hose
- ⑦ Sealed cell battery is included

Delivering quality

ALCAD

Water cart equipment operation

- 1 The battery for the watering cart is shipped disconnected. Before using the cart, connect the battery according to supplied instruction.
- 2 Remove the cap ③ and fill tank with ONLY distilled or de-ionized water (per IEC 60993). Replace the cap when full.
- 3 Connect the output hose ⑥ of the watering cart to the bottom of the filling pistol's handle. A quick connector is preassembled.
- 4 Turn the power switch ⑤ to the ON position. The switch is located on the back of the cart. The pump will energize for a few seconds and then stop.
- 5 Refer to "Filling pistol operation" (page 3).
- 6 Once all topping-up is complete, turn the power switch to the OFF position.
- 7 Charge the cart battery as needed. The battery needs 13 hours to fully charge. The battery shall be kept at a good level of charge.

Note: The watering cart cannot be operated while the charger is connected to the battery.

The expected run time of the watering cart, with a fully charged battery, is 2 hours continuous. Longer run times are likely with intermittent use of the system.

Table 1 - Water cart equipment

Container capacity	37.5 L (made in polypropylene)
Charger	120 V/230 V with exchangeable AC plug models
Hose	≈ 3.2 m in length
Battery Dimensions (mm)	12 V/7.2 Ah 150 x 64 x 94 (L x W x H)
Dimensions (mm)	432 x 432 x 940 (L x W x H)
Packaging dimensions (mm)	413 x 413 x 950 (L x W x H)
Weight	14 kg (empty), 52 kg (full)

Table 2 - Parts list equipment

Item	Part Number for pocket plate cells	Part Number for Sintered/PBE, XHP cells
Complete topping-up equipment with universal charger 120 V/230 V (with filling pistol, spacer tube kit, charger + plugs)	08-00195-04	220325
Filling pistol (with spacer tube kit)	01-02002-01	220323
Spacer tube kit (with spacer tubes marked A to H)	01-02007-01	220 974
Battery charger (120 /230 V) + plugs (2-Pin Euro plug, 3-Pin UK plug, 2-Pin US plug)	01-02011-01	220 975

Topping-up

Filling pistol operation

- 1 Select the appropriate spacer tube for the cell type that is to be replenished. Refer to Tables 4 and 5 for correct spacer tube identification. Each spacer tube is individually marked with an identity letter.
- 2 Attach spacer tube to the front end of the probe.
- 3 Position the spacer tube so the stepped inside diameter is attached to the probe first; it must face up. The smooth (non-stepped) diameter must face down.
- 4 Push the spacer tube completely against the probe top. There should be **NO** visible space between the spacer tube and the probe top. Correct positioning of spacer tubes is illustrated on page 3.
- 5 Insert the probe of the filling pistol into the battery cell. Squeeze the handle until you feel the pistol shut off. The pump will also shut off at the same time. Release the handle. Remove the probe.

Note: Some water may drip from the probe after the handle is released. Allow this to drain into the cell or into another suitable receptacle.

- 6 Repeat above steps for each cell to be replenished.

Caution:

Use correct spacer tube to prevent overfilling or underfilling.

Only use distilled or de-ionized water. NEVER use tap water.

Topping-up equipment should be dedicated to Ni-Cd batteries.

Table 3 - Filling pistol

Total filling pistol length (mm)	625
Packaging dimensions (mm)	800 x 200 x 50 (L x W x H)
Kit of 8 spacer tubes supplied	Marked A to H
To function correctly, the filling pistol requires	1 – 1.7 bar

Correct installation for spacer tubes specified in Tables 4 and 5



Spacer Tubes A, B, C, D, E, F, H

Spacer Tube G



**SAFETY DATA SHEET
SECONDARY BATTERY
(FORM : EEC Directive 93/112)**

Date of issue : June 2006
REF. MSDS-IBG-ALCAD - Bdx-EN

1. IDENTIFICATION

- 1.1. **PRODUCT** NICKEL CADMIUM BATTERY (Rechargeable & Alkaline & vented)
- Trade name :** XHP cells plastics.
- IEC Designation :** KH acc. to IEC 60623
- Proper shipping name :** BATTERIES, WET, FILLED WITH ALKALI electric storage.
- Electrochemical System :** Nickel Cadmium, alkaline electrolyte.

Electrode Positive	Nickel hydroxide and Cobalt hydroxide Nickel Plated
Electrode Négative	Cadmium Hydroxyde on Nickel plated substrade
Electrolyte	Potassium Hydroxide + water
Nominal voltage	1,2 V

1.2. SUPPLIER

- NAME :** Alcad Limited
- Address :** Norra Strandgatan – PO BOX 504, SE-572 25 Oskarshamn – Sweden -
- Phone/Fax :** +46 491 68 100 / +46 491 68 110
- Factory Address :** 111/113 Boulevard Alfred DANEY – 33074 BORDEAUX – France –
- Phone/Fax :** +33 (0) 5 57 10 64 00/ +33 (0) 5 57 10 66 70

- 1.3. **EMERGENCY CONTACT :** www.alcad.com look for « contact ».

2. COMPOSITION (weight percentage of basic materials)

2.1. MEDIUM SIZE SINGLE CELL WITH PLASTIC CONTAINER

Métals %	Plastic %	Other %
Steel Fe 20	Polypropylène 8-12	Potassium Hydroxyde 5,5-6,5
Nickel Ni 5-10	Rubber 1-2	Lithium Hydroxyde 0,5
Cadmium Cd 5-14		
		Water 28-35

3. HAZARDS

3.1. PHYSICAL

No risk if batteries are used for its intended purpose and according to valid directions for use.

If the directions for use are not followed as regards ventilation, oxygen and hydrogen gas, which may developed during over charging the batteries, can be collected in battery box or room. If the gas is ignited by an electric spark or open fire, a violent explosion may occur.

3.2. CHEMICAL

In normal use the only chemical risk is the caustic nature of the electrolyte. Precautions must be taken when emptying and filling the battery cells. The properties of the electrode materials are hazardous only if the materials are released by crushing the battery or if it is exposed to fire.

CLASSIFICATION OF DANGEROUS SUBSTANCES CONTAINED INTO THE PRODUCT.

SUBSTANCES				CLASSIFICATION			
Name	Chemical	EINECS Number	CAS Number	Letter	Identification of danger	Special risk (1)	Safety advice -2
Nickel hydroxide	Ni (OH) ₂	235-008-5	12054-48-7	Xn	Harmful	R20/22 R40, R43	S2, S22, S26
Cadmium hydroxide	Cd (OH) ₂	244-168-5	21041-95-2	Xn	Harmful	R20/21/22 R50/53	S2, S60, S61
Potassium hydroxide	KOH	215-181-3	1310-58-3	C Xi	Corrosive Irritant	R35, R22, R36/37	S ^{1/2} , S26, S36/37/39, S45
Lithium hydroxide	Li OH	215-183-4	1310-65-2	C	Not classified	Not classified	Not classified
Cobalt hydroxide	Co (OH) ₂	244-166-4	21041-93-0	C	Not classified	Not classified	Not classified Not classified
Chromium	Cr	231-157-5	774-47-3		Not classified	Not classified	Not classified

(1) Nature of special risk

- R20/22 Harmful by inhalation and if swallowed
R20/21/22 Harmful by inhalation, in contact with skin and if swallowed.
R22 Harmful if swallowed.
R35 Causes severe burns.
R36/37 Irritating to eyes and respiratory system.
R40 Limited evidence of a carcinogenic effect.
R43 May cause sensitization by skin contact.
R50/53 Very Toxic to aquatic organisms, may cause long-term adverse effects in the aquatic environment.

(2) Safety advice

- S_{1/2} Keep locked up and out of the reach of children.
S2 Keep out of the reach of children
S22 Do not breathe dust
S26 In case of contact with eyes, rinse immediately with plenty of water and seek medical advice
S36/37/39 Wear suitable protective clothing, gloves and eyes/face protection.
S45 In case of accident or if you feel unwell, seek medical advice immediately.
S60 Must be disposed of as hazardous waste.
S61 Avoid release to the environment.

4. FIRST AID MEASURES

When handling electrolyte, precautions must be taken to avoid personal to get in direct contact with it. If this accidentally happens the following must be exercised :

4.1. Inhalation :

Fresh air. Rinse mouth and nose with water. Medical treatment.

Rinse immediately with plenty of water. Medical treatment.

4.3. Eyes contact:

Important : Rinse immediately with plenty of water during at least 15-30 minutes.

4.4. Ingestion :

If the injured is fully conscious : plenty of drink ; preferable milk. Do not induce vomiting. Immediately hospital treatment.

5. FIRE-FIGHTING MEASURES

5.1. Extinguishing media

Suitable : Class D-Dry chemical, Sand
Not to be used : Water

5.2. Special exposure hazards

Cells can be overheated by an external source or by internal shorting and develop potassium hydroxide mist and/or hydrogen gas. In fire situations fumes containing Cadmium, Nickel and Iron may be evolved.

5.3. Special protective equipment

Use self-contained breathing apparatus and full fire-fighting protective clothing.

6. ACCIDENTAL RELEASE MEASURES

Flush electrolyte spillage with plenty of water. Beware risk of slipping.

7. HANDLING AND STORAGE

Handle and store cells filled with electrolyte always with vents upwards.

Store in a dry place.

8. EXPOSURE CONTROLS/PERSONAL PROTECTION

When emptying or filling cells with electrolyte, eye protection glasses and protection gloves must be used.

Under normal condition of use no special personnel protection is required.

9. PHYSICAL PROPERTIES

9.1. Appearance

Physical shape and colour as supplied.

9.2. Temperature range (ambient °C)

Cell type	Continuous	Occasional
Plastic container	-40 +50	-50 +70

9.3. Specific energy : 13-22 Wh/kg

Note : WH : Nominal voltage x rated Ah as defined in IEC standard.
Kg : Average battery weight in kg.

9.4. Specific instant power : 53-106 W/kg

Note : W =0.5 x nominal voltage x Ip with Ip = current in Amperes delivered by a fully charged battery for half the nominal voltage at one second.

Kg = Average battery weight in kg.

9.5. Mechanical resistance

As defined in relevant IEC standard.

10. STABILITY AND REACTIVITY

10.1. Conditions to avoid

Temperatures over 85°C. short-circuit of electrode connections. Deformation of cells.

10.2. Material to avoid

Do not fill cells with lead/acid battery electrolyte.

10.3. Hazardous decomposition products

11. TOXICOLOGICAL INFORMATION

Nickel hydroxide LD₅₀/ oral / rat : 1600mg / kg*

Cadmium Hydroxyde No data available

Potassium Hydroxyde LD₅₀/ oral / rat : 365 mg / kg*

Lithium Hydroxyde No data available.

* (INRS data)

12. ECOLOGICAL INFORMATION

See item n° 3

13. DISPOSAL CONSIDERATIONS

13.1. Incineration

Never incinerate NiCd cells.

13.2. Landfill

Never dispose NiCd cells as landfill.

13.3. Recycling

NiCd cells must be recycled. Contact local Alcad dealer for information. Alcad has a recycling plant for all types of NiCd cells.

14. TRANSPORT INFORMATION

14.1. United Nations

UN N° : 2795

14.2. International conventions

Air : IATA
Sea : IMDG
Land : ADR (road) or RID (rail) Batteries exempt acc to special paragraph n° 598.

UN N°	NAME	RAIL & ROAD (ADR)				SEA (IMDG)					AIR (IATA)			
		CL	Code	Packing group	Labelling	CL	risk	EmS	Packing group	Labelling	CL	Risk	Packing group	Labelling
2795	BATTERIES, WET, FILLED WITH ALKALI Electric storage	8	C 11	***	None	8	***	8-10	III	8	8	***	***	8

15. REGULATORY INFORMATION

According to item 14.2.

16. OTHER INFORMATIONS

None.

Disclaimer : This information has been compiled for sources considered to be dependable and is, to the best of our knowledge and belief, accurate and reliable as of the dated compiled. However, no representation, warranty (either expressed or implied) or guarantee is made to the accuracy, reliability or completeness of the information contained herein. This information relates to the specific material designated and may not be valid for such material used in combination with any other materials or in any process. It is the user's responsibility to satisfy himself as to the suitability and completeness of this information for his own particular use. We do not accept liability for any loss or damage that may occur, whether direct, indirect, incidental or consequential, from the use of this information nor do we offer warranty against patent infringement. Additional information is available by calling the telephone number above designated for this purpose.

**SAFETY DATA SHEET
SECONDARY BATTERY
(FORM : EEC Directive 93/112)**

Date of issue : APRIL 2008
REF. MSDS-IBG-ALCAD-ENG

1. IDENTIFICATION

- 1.1. **PRODUCT** NICKEL CADMIUM BATTERY (Rechargeable & Alkaline & vented)
Trade name : LC/LCE/MC/HC/LBP/LBE/MBP/HBP/VNVTX1L/VTX1M, and other plastics/steel cells.
IEC Designation : KH ; KM ; KL acc. To IEC 60623
Proper shipping name : BATTERIES, WET, FILLED WITH ALKALI electric storage.

Electrochemical System : Nickel Cadmium, alkaline electrolyte.

Electrode Positive	Nickel hydroxide and Cobalt hydroxide Nickel Plated
Electrode Négative	Cadmium Hydroxyde and iron oxide on Nickel plated substrade
Electrolyte	Potassium Hydroxide + water
Nominal voltage	1,2 V

1.2. SUPPLIER

Name : Alcad Limited
Address : Norra Strandgatan 35 Box 504, S-572 25 Oskarshamn, Sweden
Phone/Fax : +46 491 68 100/ +46 491 68 110

1.3. **EMERGENCY CONTACT :** www.alcad.com look for « contact ».

2. COMPOSITION (weight percentage of basic materials)**2.1. MEDIUM SIZE SINGLE CELL WITH STEEL CONTAINER**

Métals%	Plastic %	Other %
Steel Fe 43-51	Polypropylene 1,1-1,6	Potassium hydroxide 5,4-5,8
Nickel Ni 3-10		Lithium Hydroxyde 0,5
Cadmium Cd 3-10		
Chromium Cr 2,3-2,6		Water 27-31
Cobalt < 0.3		

2.2. MEDIUM SIZE SINGLE CELL WITH PLASTIC CONTAINER

Métals %	Plastic %	Other %
Steel Fe 20	Polypropylène 8-11	Potassium Hydroxyde 5,5-6,2
Nickel Ni 3-10		Lithium Hydroxyde 0,5
Cadmium Cd 3-10		Carbon 2-4
		Water 28-35

3. HAZARDS

3.1. PHYSICAL

No risk if batteries are used for its intended purpose and according to valid directions for use.

If the directions for use are not followed as regards ventilation, oxygen and hydrogen gas, which may developed during over charging the batteries, can be collected in battery box or room. If the gas is ignited by an electric spark or open fire, a violent explosion may occur.

3.2. CHEMICAL

In normal use the only chemical risk is the caustic nature of the electrolyte. Precautions must be taken when emptying and filling the battery cells. The properties of the electrode materials are hazardous only if the materials are released by crushing the battery or if it is exposed to fire.

CLASSIFICATION OF DANGEROUS SUBSTANCES CONTAINED INTO THE PRODUCT.

SUBSTANCES				CLASSIFICATION			
Name	Chemical	EINECS Number	CAS Number	Letter	Identification of danger	Special risk (1)	Safety advice -2
Nickel hydroxide	Ni (OH) ₂	235-008-5	12054-48-7	Xn	Harmful	R20/22 R40, R43	S2, S22, S26
Cadmium hydroxide	Cd (OH) ₂	244-168-5	21041-95-2	Xn	Harmful	R20/21/22 R50/53	S2, S60, S61
Potassium hydroxide	KOH	215-181-3	1310-58-3	C Xi	Corrosive Irritant	R35, R22, R36/37	S ^{1/2} , S26, S36/37/39, S45
Lithium hydroxide	Li OH	215-183-4	1310-65-2	C	Not classified	Not classified	Not classified
Cobalt hydroxide	Co (OH) ₂	244-166-4	21041-93-0	C	Not classified	Not classified	Not classified
Chromium	Cr	231-157-5	774-47-3		Not classified	Not classified	Not classified

(1) Nature of special risk

- R20/22 Harmful by inhalation and if swallowed
R20/21/22 Harmful by inhalation, in contact with skin and if swallowed.
R22 Harmful if swallowed.
R35 Causes severe burns.
R36/37 Irritating to eyes and respiratory system.
R40 Limited evidence of a carcinogenic effect.
R43 May cause sensitization by skin contact.
R50/53 Very Toxic to aquatic organisms, may cause long-term adverse effects in the aquatic environment.

(2) Safety advice

- S_{1/2} Keep locked up and out of the reach of children.
S2 Keep out of the reach of children
S22 Do not breathe dust
S26 In case of contact with eyes, rinse immediately with plenty of water and seek medical advice
S36/37/39 Wear suitable protective clothing, gloves and eyes/face protection.
S45 In case of accident or if you feel unwell, seek medical advice immediately.
S60 Must be disposed of as hazardous waste.
S61 Avoid release to the environment.

4. FIRST AID MEASURES

When handling electrolyte, precautions must be taken to avoid personal to get in direct contact with it. If this accidentally happens the following must be exercised :

4.1. Inhalation :

Fresh air. Rinse mouth and nose with water. Medical treatment.

4.2. Skin contact :

Rinse immediately with plenty of water. Medical treatment.

4.3. Eyes contact:

Important : Rinse immediately with plenty of water during at least 15-30 minutes.

4.4. Ingestion :

If the injured is fully conscious : plenty of drink ; preferable milk. Do not induce vomiting. Immediately hospital treatment.

5. FIRE-FIGHTING MEASURES

5.1. Extinguishing media

Suitable : Class D-Dry chemical, Sand

Not to be used : Water

5.2. Special exposure hazards

Cells can be overheated by an external source or by internal shorting and develop potassium hydroxide mist and/or hydrogen gas.

In fire situations fumes containing Cadmium, Nickel and Iron may be evolved.

5.3. Special protective equipment

Use self-contained breathing apparatus and full fire-fighting protective clothing.

6. ACCIDENTAL RELEASE MEASURES

Flush electrolyte spillage with plenty of water. Beware risk of slipping.

7. HANDLING AND STORAGE

Handle and store cells filled with electrolyte always with vents upwards.

Store in a dry place.

8. EXPOSURE CONTROLS/PERSONAL PROTECTION

When emptying or filling cells with electrolyte, eye protection glasses and protection gloves must be used.

Under normal condition of use no special personnel protection is required.

9. PHYSICAL PROPERTIES

9.1. Appearance

Physical shape and colour as supplied.

9.2. Temperature range (ambient °C)

Cell type	Continuous	Occasional
Steel container	-40 +50	-50 +85
Plastic container	-40 +50	-50 +70

9.3. Specific energy : 13-22 Wh/kg

Note : WH : Nominal voltage x rated Ah as defined in IEC standard.

Kg : Average battery weight in kg.

9.4. Specific instant power : 53-106 W/kg

Note : $W = 0.5 \times \text{nominal voltage} \times I_p$ with I_p = current in Amperes delivered by a fully charged battery for half the nominal voltage at one second.

Kg = Average battery weight in kg.

9.5. Mechanical resistance

10. STABILITY AND REACTIVITY

10.1. Conditions to avoid

Temperatures over 85°C. short-circuit of electrode connections. Deformation of cells.

10.2. Material to avoid

Do not fill cells with lead/acid battery electrolyte.

10.3. Hazardous decomposition products

Nickel compounds, Cadmium compounds, Caustic liquid.

11. TOXICOLOGICAL INFORMATION

Nickel hydroxide LD₅₀/ oral / rat : 1600mg / kg*

Cadmium Hydroxyde No data available

Potassium Hydroxyde LD₅₀/ oral / rat : 365 mg / kg*

Lithium Hydroxyde No data available.

* (INRS data)

12. ECOLOGICAL INFORMATION

See item n° 3

13. DISPOSAL CONSIDERATIONS

13.1. Incineration

Never incinerate NiCd cells.

13.2. Landfill

Never dispose NiCd cells as landfill.

13.3. Recycling

NiCd cells must be recycled. Contact local Alcad Limited dealer for information.

14. TRANSPORT INFORMATION

14.1. United Nations

UN N° : 2795

14.2. International conventions

Air : IATA
Sea : IMDG
Land : ADR (road) or RID (rail) Batteries exempt acc to special paragraph n° 598.

UN N°	NAME	RAIL & ROAD (ADR)				SEA (IMDG)					AIR (IATA)			
		CL	Code	Packing group	Labelling	CL	risk	EmS	Packing group	Labelling	CL	Risk	Packing group	Labelling
2795	BATTERIES, WET, FILLED WITH ALKALI Electric storage	8	C 11	***	None	8	***	8-10	III	8	8	***	***	8

15. REGULATORY INFORMATION

According to item 14.2.

16. OTHER INFORMATIONS

None.

Disclaimer : This information has been compiled for sources considered to be dependable and is, to the best of our knowledge and belief, accurate and reliable as of the dated compiled. However, no representation, warranty (either expressed or implied) or guarantee is made to the accuracy, reliability or completeness of the information contained herein. This information relates to the specific material designated and may not be valid for such material used in combination with any other materials or in any process. It is the user's responsibility to satisfy himself as to the suitability and completeness of this information for his own particular use. We do not accept liability for any loss or damage that may occur, whether direct, indirect, incidental or consequential, from the use of this information nor do we offer warranty against patent infringement. Additional information is available by calling the telephone number above designated for this purpose.

S3.4 Edition: April 2007

Produced by Arthur Foculdes.
Photo credits: Alcad, Akstom/Philippe GUGIARD, Thierry Balazac,
Bob Fleumer, Getty Images, Natalie Loundon.
Data in this document are subject to change without notice
and become contractual only after written confirmation by Alcad.

FGC ELECTRIC
INFO@FGCELECTRIC.COM
E. T. +902122551863 - 64
ISTANBUL TURKEY

Alcad Limited



Sweden

Telephone: +46 491 68 100

Facsimile: +46 491 68 110

Delivering quality

ALCAD